



HVLP AIR CAP AND FLUID NOZZLE CHART

MODEL NO.	AIR CAPS	PRESS. OR SIPHON	*MAX GUN INLET PRESS. FOR HVLP	FAN CONTROL	SCFM @ MAX GUN INLET	AIR CAP RING	STANDARD IN CAT PACK	AVAILABLE FLUID NOZZLES TIPS	NEEDLES / marking on needle
LYNX 100H (L100H)	21-1090	pressure	15	60-1502 (#2)	6	21-1001		31-0205 0.5mm (.020")	40-1100 (100)
	21-1091	pressure	15		8		Included	31-0208 0.8mm (.022")	
	21-1092	pressure	15		8			31-0210 1.0mm (.040")	
	21-1093	pressure	18		10			31-0212 1.2mm (.046")	
	21-1094	pressure	33		13		Included	31-0213 1.3mm (.052")	
	21-1095	pressure	50		22.5			31-0214 1.4mm (.055")	
	21-1097	pressure	50		22.5			31-0215 1.5mm (.059")	
	21-1195	pressure	50		22.5		Included		
	21-1197	pressure	50		22.5	Included		31-0217 1.7mm (.070")	
								31-0414 1.4Fmm (.055")	40-1114F (114F)
								31-0417 1.7Fmm (.070")	40-1117F (117F)

Actual fluid nozzle and air cap combinations are determined by application (see application chart page 4)

*Note: Air cap test gages are available to confirm HVLP compliance.

*Gun inlet pressures may vary as required by application

Operation and Maintenance Instructions for *L100H* Spray Guns

Operation

1. Connect air supply hose at handle of gun.
2. Connect a pressurized fluid supply to the gun fluid inlet.
3. Fluid flow can be controlled using the fluid control knob, this restricts flow by limiting needle travel. It is best to control fluid flow by proper selection of fluid orifice size and use the fluid control knob to “fine tune flow rate”.
4. Fan width can be adjusted using the fan control knob. Turning the knob clockwise narrows the fan.

Maintenance

IMPORTANT! Routine cleaning and maintenance is essential to insure proper gun operation.

Several states prohibit spraying solvent into the atmosphere and require the use of covered gun cleaner.

1. If a gun cleaner is being used, connect and clean the gun in the gun cleaner according to the manufactures instructions.
2. If a gun cleaner is not being used:
Remove air cap and clean separately using clean solvent.
For pressure setups, connect a pressurized solvent supply to the fluid inlet, trigger the gun allowing solvent to flow thru the gun until clean.

NOTE: Gun head disassembly is not recommended for normal cleaning and maintenance.

Gun head disassembly and reassembly instructions:

Have repair kit # 10-106 available before gun disassembly.

Gun head disassembly

To remove the nozzle carrier (5) and air cap adapter (6):

1. Remove the air cap (1-2), fluid nozzle tip (3), fluid nozzle body (4), and needle (13).
2. Remove the needle seal cartridge (23).
3. Loosen the locknut (9) and remove fluid inlet (10) using a 5/8” open-end wrench.
4. The nozzle carrier (5) and air cap adapter (6) will now slide forward from the gun body (11).

Gun head reassembly

1. Install a new o-ring (7) on the air cap adapter (6).
2. Install the thread locknut (9) onto the fluid inlet (10) as far as possible.
3. Install a new fluid inlet seal (8) into the recess area on the nozzle carrier (5) inlet port.
4. Slide the nozzle carrier (5) into air cap adapter (6) and insert into the gun body (11) as far as possible. Be sure the nozzle carrier (5) extends into the hole at the back of the gun head. Install the needle seal (23) but do not tighten.
5. Rotate the nozzle carrier (5) until the fluid inlet port in the nozzle carrier (5) is aligned with the threaded hole in the body. While in this position, insert the fluid inlet (10) and tighten firmly.
6. Tighten the needle seal (23) to approx. 12 ft.-lb. torque.
7. Tighten the fluid inlet (10) to approx. 25 ft.-lb. torque.
8. Tighten the locknut (9) to approx. 33 ft.-lb. torque.

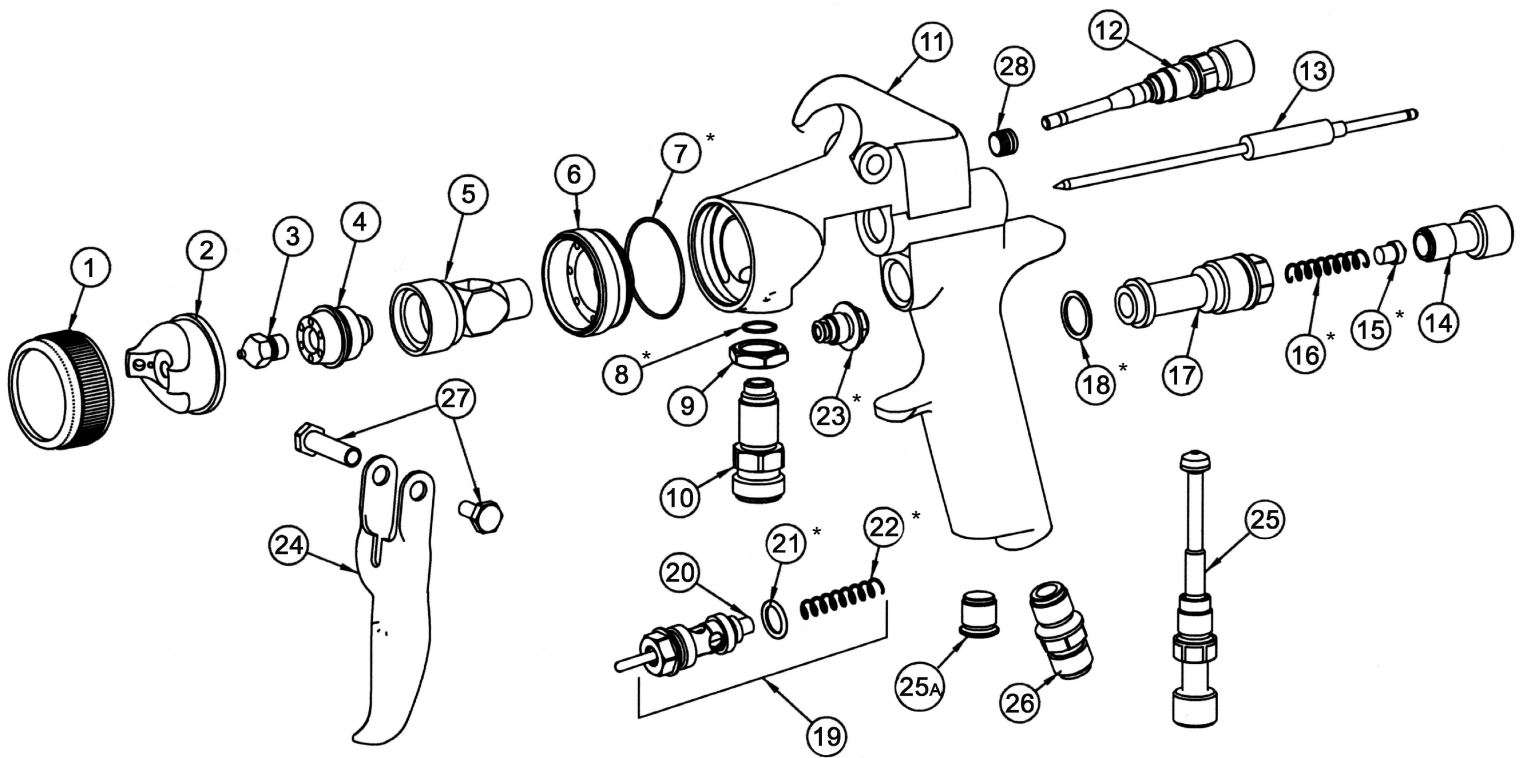

HVLP AIR CAP TEST GAGES

FOR L100H GUNS	21-1090-G
	21-1092-G
	21-1093-G
	21-1095-G
	21-1097-G
	21-1195-G
	21-1197-G

ITEM NO.	PART NO.	DESCRIPTION	ITEM NO.	PART NO.	DESCRIPTION
1	See Air Cap Chart	Air Cap Retaining Ring**	16	60-204	Needle Return Spring*
2	See Air Cap Chart	Air Cap**	17	60-201	Rear Bushing
3	See Air Cap Chart	Fluid Nozzle Tip**	18	60-119	Seal*
4	31-1201	Fluid Nozzle Body	19	60-1520	Air Valve Assembly
5	60-L11H	Nozzle Carrier	20	60-302	Air Valve Poppet
6	60-12H	Air Cap Adapter	21	60-125	O-Ring*
7	60-131	O-Ring*	22	61-1003	Air Valve Spring*
8	60-124	Fluid Inlet Seal	23	60-1400	Needle Seal Cartridge*
9	60-128	Locknut	24	60-2101	Trigger
10	60-126	Fluid Inlet Fitting	25	60-1510	Air Control
11	60-1114	Lynx Gun Body HVLP	25A	60-122	Plug (optional)
12	See Air Cap Chart	Fan Control Assembly**	26	60-104	Air Inlet Fitting
13	See Air Cap Chart	Fluid Needle**	27	60-1033	Trigger Pivot Set
14	60-202	Fluid Control Knob	28	98-0109	Allen Plug
15	60-205	Spring Seat*			

**See air cap selection chart on page 1

*Indicates part included in repair kit # 10-106

FLUID NOZZLE / AIR CAP SELECTION CHARTS

LYNX Series 100H - Pressure Feed Guns

L100H HVLP SPRAY GUN

MATERIAL TYPE	FLUID ORIFICE x AIR CAP	MAXIMUM PATTERN WIDTH	PRESS. / SIPHON
Very Thin less than 16 sec. Zahn #2 inks , dyes, solvents, stains	0.5, 0.8 mm x 1090	10	P
	0.5, 0.8 mm x 1092	11	P
Thin 16 to 20 sec. Zahn #2 lacquers, enamels, primers, sealers	1.0, 1.2 mm x 1092	11	P
	1.0, 1.2 mm x 1093	12	P
Medium 21 to 30 sec. Zahn #2 automotive base coat enamels, primers epoxies, urethanes automotive clear coat	1.3, 1.4, 1.5 mm x 1093	12	P
	1.3, 1.4, 1.5 mm x 1095	12	P
	1.3, 1.4, 1.5 mm x 1097	13	P
Heavy over 30 sec. Zahn #2 heavy body primers high solid enamels high solid automotive coatings adhesives	1.6, 1.7 mm x 1095	12	P
	1.6, 1.7 mm x 1097	13	P
	1.6, 1.7 mm x 1195	13	P
	1.6, 1.7 mm x 1197	14	P

CP-L100H Smart Pack Includes:

- 98-0104 3/8" Socket
 - 98-0112 Ratchet Wrench
 - 60-8001 Gun Wrench
 - 98-0113 Gun Cleaning Brush
- Air Caps and Needles Shown on Page 1*



CP-L100H

CP-L100H-303R2 Includes:

- 51-303 1 QT Aluminum Pressure Cup
 - 52-5R2 Pressure Cup Regulator
 - 98-0104 3/8" Socket
 - 98-0112 Ratchet Wrench
 - 60-8001 Gun Wrench
 - 98-0113 Gun Cleaning Brush
- Air Caps and Needles Shown on Page 1*



CP-L100H-303R2

CP-L100H-PPSR2 Includes:

- 91-460 950 mL 3M™ PPS™ Pressure Cup
 - 91-462 Lids and Liners (Available in 25 Pack)
 - 91-475 #18 PPS Adapter
 - 52-5R2 Pressure Cup Regulator
 - 98-0104 3/8" Socket
 - 98-0112 Ratchet Wrench
 - 60-8001 Gun Wrench
 - 98-0113 Gun Cleaning Brush
- Air Caps and Needles Shown on Page 1*



CP-L100H-PPSR2



MODEL NUMBER

DESCRIPTION

70-254

Double Diaphragm Pump (Bare Pump)

70-1101-5

5 Gallon Wall Mount (5 Gallon Siphon)

70-1101-55

55 Gallon Wall Mount (55 Gallon Siphon)

70-1102-5

5 Gallon Cart Mount (5 Gallon Siphon)

70-1102-55

55 Gallon Cart Mount (55 Gallon Siphon)

70-1103

5 Gallon Pail Mount

70-1104

5 Gallon Pail Mount With Agitator

70-1105

55 Gallon Drum Mount

70-1106

55 Gallon Drum Mount With Agitator

Installation

The CAT Pump comes with a footed base for easy mounting in permanent installations. The pump should be mounted in a vertical position. In permanent installations, the pump should be attached to plant piping using flexible coupling on both the intake and discharge connections to reduce vibration to the pump and piping. To further reduce vibration, a surge suppressor next to the pump may be used. Suction pipe size should be at least 1/2 inch in diameter or even larger if highly viscous fluid is to be pumped. If suction hose is used, it must be of a non-collapsible reinforced type. Discharge piping should be of at least 1/2 inch. It is critical, especially on the suction side of the pump, that all fittings and connections are airtight or pumping will be reduced and priming will be difficult. The air supply line should be at least 3/8-inch diameter. Make certain the supplying line and compressor are capable of supplying the required pressure and volume of air to operate the pump at the desired flow rate. The quality of the compressed air source should be considered. Air that is contaminated with moisture and dirt may result in erratic pump performance and increased maintenance cost as well as frequent process "down time" when the pump fails to operated properly.

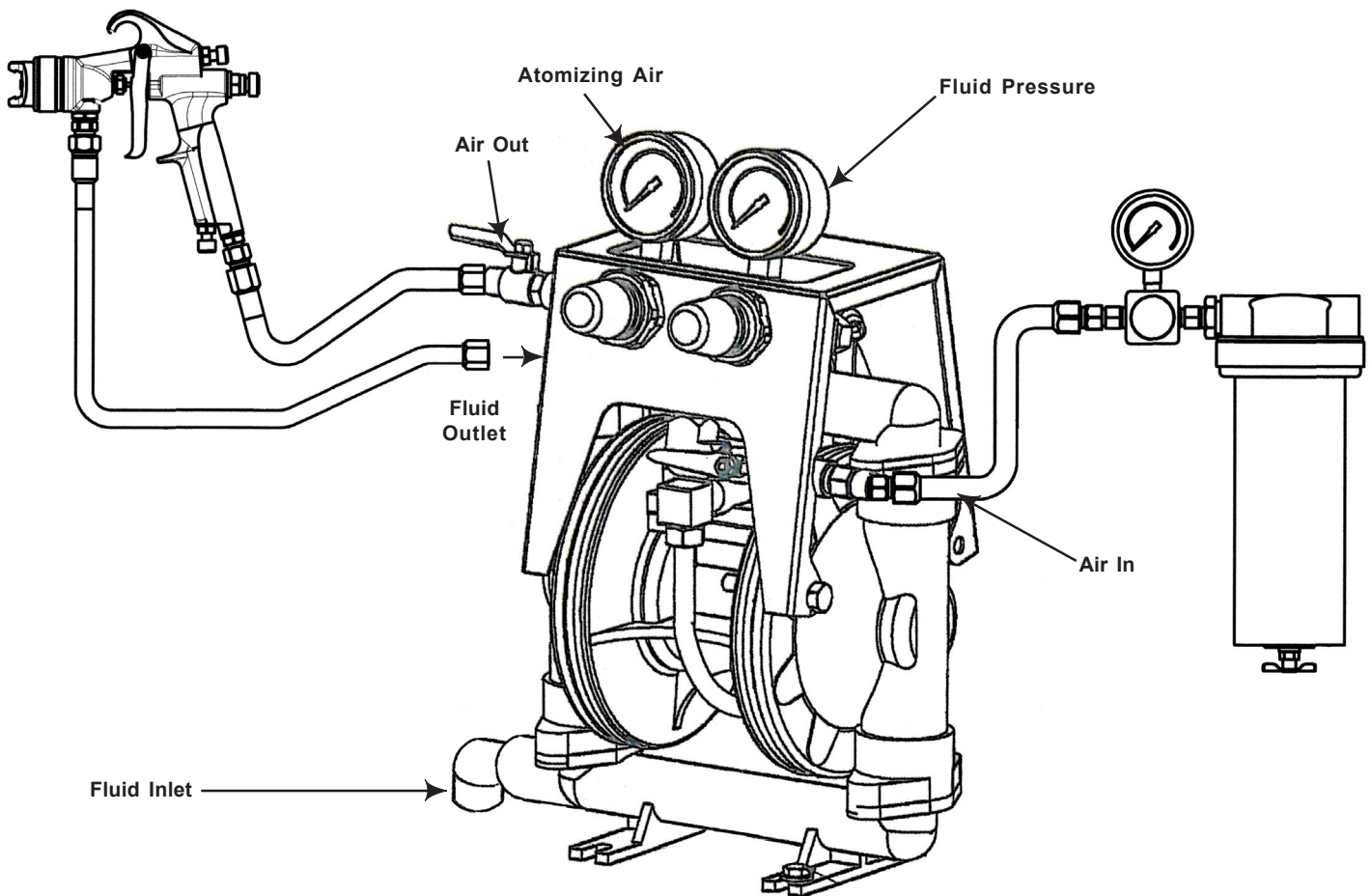

Flow Rate Adjustable 0-12 gpm (45 Lpm)

Port Size:

Inlet & Outlet..... 1/2" NPT

Air Inlet..... 1/4" NPT

Air Exhaust..... 1/4" NPT

Suction Lift..... 20'(6.09m) Wet

Max. Particle Dia..... (.0625") (1.6mm)

Pump Operation

The pump is powered by compressed air. Compressed air is directed to the pump air chamber by the main air valve. The compressed air is separated from the fluid by a membrane called a diaphragm. The diaphragm in turn applies pressure on the fluid and forces it out of the pump discharge. While this is occurring, the opposite air chamber is depressurized and exhausted to atmosphere and fluid is drawn into the pump suction. The cycle again repeats, thus creating a constant reciprocating action that maintains flow through the pump. The flow is always in through the bottom suction connection and out through the top discharge connection. Since the air pressure acts directly on the diaphragms, the pressure applied to the fluid roughly approximates the air supply pressure supplied to the main air valve.

Trouble Shooting

The pump will not run, or runs slowly:

1. Check the sticking air valve. Remove air valve from pump and flush with solvent to remove dirt and debris. Check spool, u-cup, and air valve bore for nicks and scratches; replace if needed. Clean all ports and replace air valve gaskets and u-cups.
2. Check pilot shaft and main shaft for scoring and scratches; replace if needed. Replace the pilot shaft and main shaft o-ring if they are worn, flat, or torn.

The pump runs, but little material flows:

1. Check for pump cavitation, slow the pump speed down to match the thickness of the material being pumped.
2. Look for sticking ball checks. If the material being pumped is not compatible with the ball material, the elastomer may swell. Replace the balls and seats with a compatible elastomer type. Check valve seats and if worn or damaged replace with new ones.
3. Make sure all the suction line fittings and connections are airtight.

Air bubbles in pump discharge

1. Look for ruptured diaphragm.
2. Check for suction leaks in pump manifolds and piping.

Material comes out of the pump air exhaust

1. Inspect the diaphragm for rupture.
2. Check the tightness of the diaphragm plates to the pump shaft.

HAZARD WARNINGS

This equipment may generate fluid pressures equal to the air supply pressure. **NEVER** exceed the recommended air supply pressure of 100 psi (6.8 bar).

ALWAYS shut-off air supply and disconnect from the pump before performing repair or maintenance to the pump.

DO NOT put your face or body near the pump air exhaust while the pump is operating.

Bleed all pressure from the discharge and suction lines before disconnecting the fluid suction or discharge lines from pump.

DO NOT operate a pump that is leaking, damaged, corroded or otherwise unable to contain the internal fluid pressure.

ALWAYS make sure safety shut-off valves, regulators, pressure relief valves, etc. are working properly before starting pump.

Fire or Explosion Hazard

Static electricity can be created by the flow of fluid through the pump or by the reciprocating action of A.O.D. Pumps. If the pump is not properly grounded, sparking may occur, and the system may become hazardous. Sparks can ignite fumes or vapor and cause an explosion.

If you experience static sparking or even a slight shock when using the pump do not continue to operate the pump until the pump is properly grounded.

Proper Grounding

Pump, valves, discharge and supply lines as well as containers must be grounded. These items must be grounded when handling flammable fluids and when static electricity discharge is a hazard.

To ground metallic pumps, connect a ground wire to any accessible point of attachment such as clamp band or mounting base.

DO NOT pump incompatible fluids through the pump. Consult your distributor or the factory if you are unsure of compatibility of fluids with pumps materials of construction.

C.A. TECHNOLOGIES pumps are designed to operate on compressed air. Other gases have not been tested and may be unsafe to use.

Before starting a pump make certain the discharge point of the piping system is not obstructed and all persons have been warned to stand clear.

Any misuse of this equipment such as over pressurization, modifying parts, pumping incompatible liquids, using worn or damaged parts or using gases other than compressed air to power the pump is not recommended. Any of these circumstances could result in splashing or spraying into the eyes, skin or possible serious bodily injury, fire, explosion or property damage.

NOISE - Wear proper ear protection when working or standing near A.O.D. Pumps.

Pump Diaphragm Failure - A.O.D. Pumps utilize an elastometric diaphragm to separate the pumping liquid from the air supply.

When this membrane ruptures pumping fluid may be expelled from the air exhaust port. Always pipe the air exhaust to a safe location or suitable container if dangerous liquids are being pumped.

Installation - Never allow the piping system to be supported by the pump manifolds or valve housing. The use of flexible piping connections is highly recommended.

Temperature Limits - The groundable acetal pump is designed to run between 10° and 180° F.

Static Electricity - Static electricity can be created by the flow of fluid through the pump or by the reciprocating action. The groundable acetal pump is provided with a groundable cable to eliminate the potential for static buildup. This cable must be grounded to an appropriate earth ground source for safe operation.

Sound Level Ratings

The following table lists the sound level ratings of C.A. Technologies pumps equipped with factory installed air exhaust mufflers. The readings were obtained with a Pacer Industries model SL-120 sound level indicator "A" scale. Readings were made at a distance of 1 meter from the pump and a height of 1.6 meters above the floor using a factory supplied air exhaust muffler. It is assumed the pumps will be installed at floor level.

Pump Series	dB(A) reading
E5, 1/2" pump	78.0 dB(A)

Temperature Limitations

Maximum Temperature limitations are based on mechanical stress only. Certain chemicals will reduce the maximum safe operating temperatures of A.O.D. Pumps. Consult your dealer or Chemical Resistance Guide for compatibility and temperature limits.

Double Diaphragm Regulator Information
For Cover Mount & Bung Mount Pumps
70-240

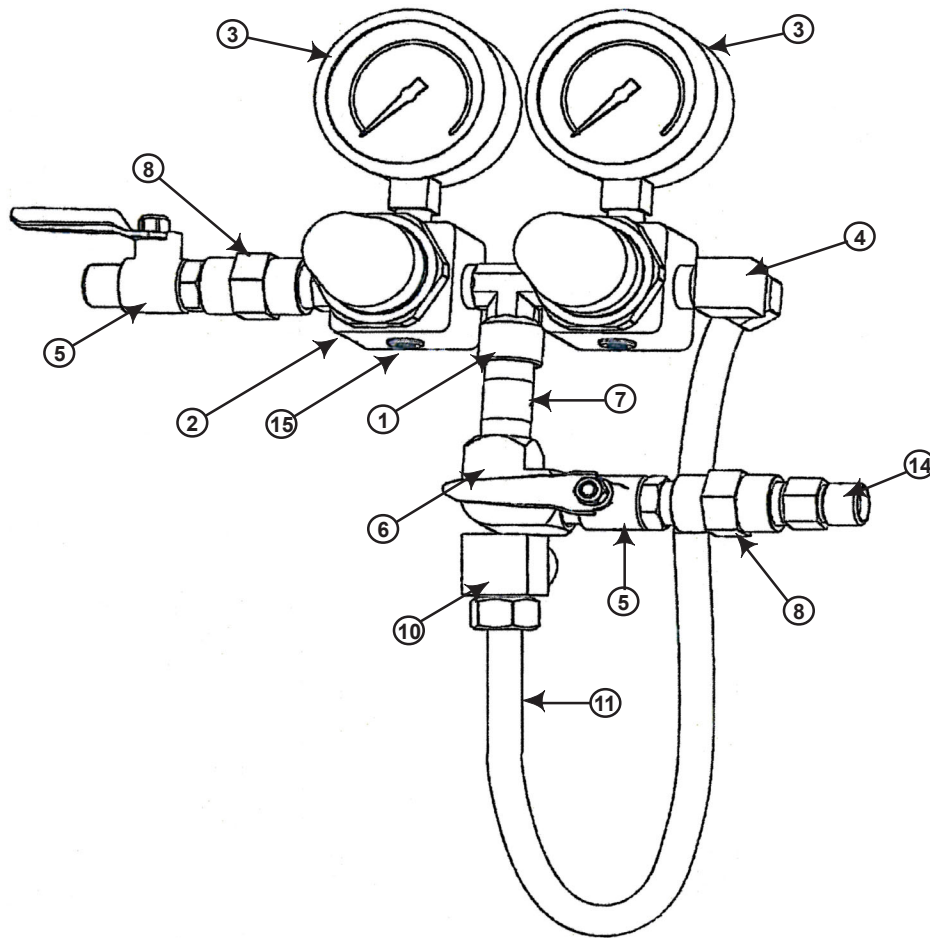

ITEM NO.	PART NO.	DESCRIPTION	ITEM NO.	PART NO.	DESCRIPTION
1	98-0225	Tee - Couplings 127VC	9	98-0215	Nipple 1/4 NPT
2	52-6	Regulator	10	95-0226	Elbow 3/8 comp x 3/8 NPT
3	52-59	Gauge 0-100 PSI	11	53-23-18	Hose
4	98-0166	Elbow	12	70-247	Panel Nut
5	52-150	Ball Valve 1/4 NPT	13	98-0218	Insert Sleeve
6	98-0176	Elbow 1/4 NPT	14	53-562 or 53-552	Nipple 1/4 NPT
7	98-0163	Nipple	15	98-0121	Plug 1/8 NPT
8	98-0159	Coupling	16	98-0163	Copy Nipple 1/4 NPT x 1 1.15

Double Diaphragm Wall Mount Bracket Information

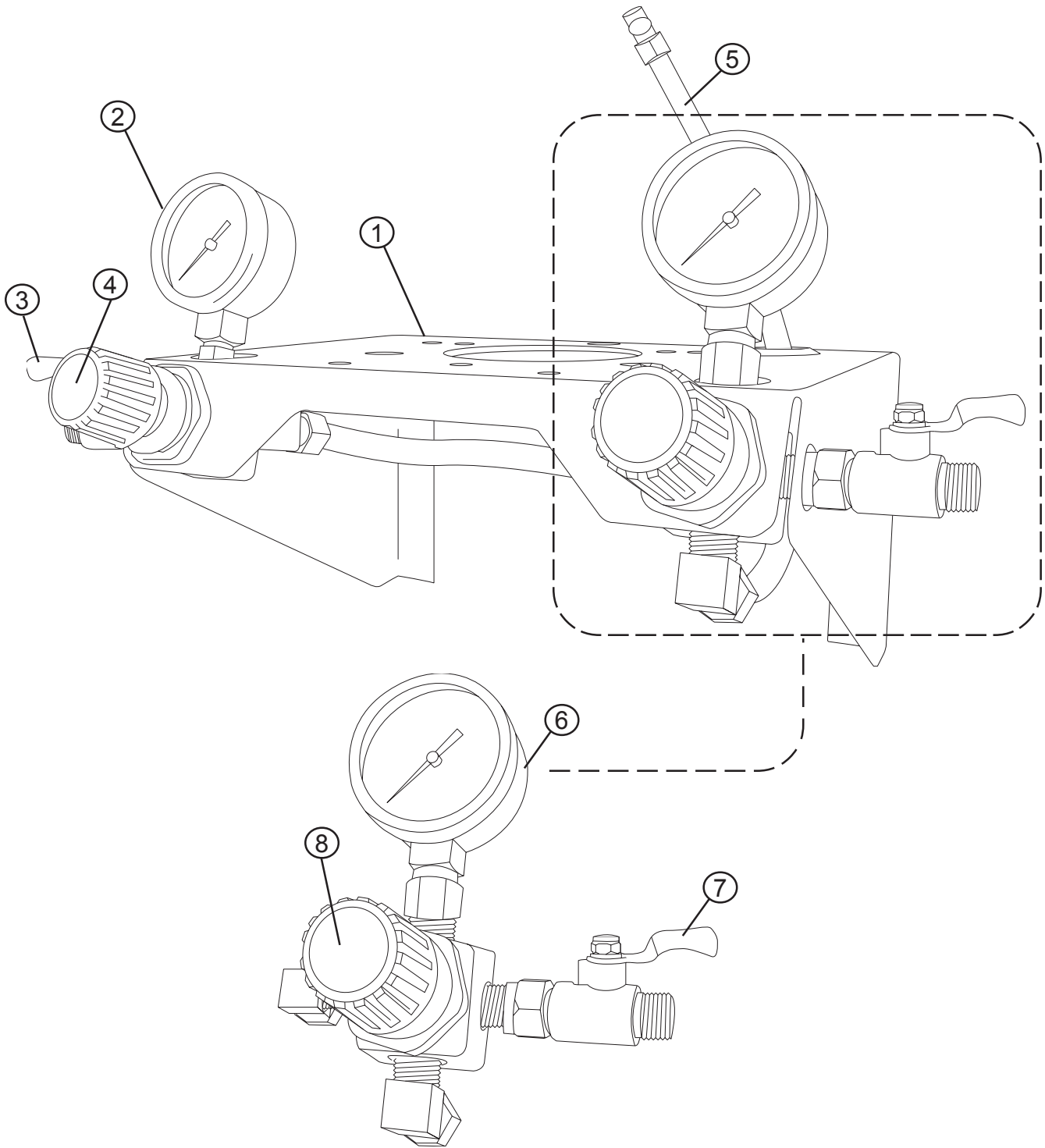

ITEM NO.	PART NO.	DESCRIPTION	ITEM NO.	PART NO.	DESCRIPTION
1	70-171	Wall Mount Bracket	5	75-146	Pump Protector Tube Assembly
2	52-60	Pressure Gage, Gun Air 0-30 psi	6	52-58	Pressure Gage, Air Motor 0-100 psi
3	52-150	Ball Valve 1/4"	7	52-150	Ball Valve 1/4"
4	75-152	Gun Regulator Assembly	8	75-151	Air Motor Regulator Assembly

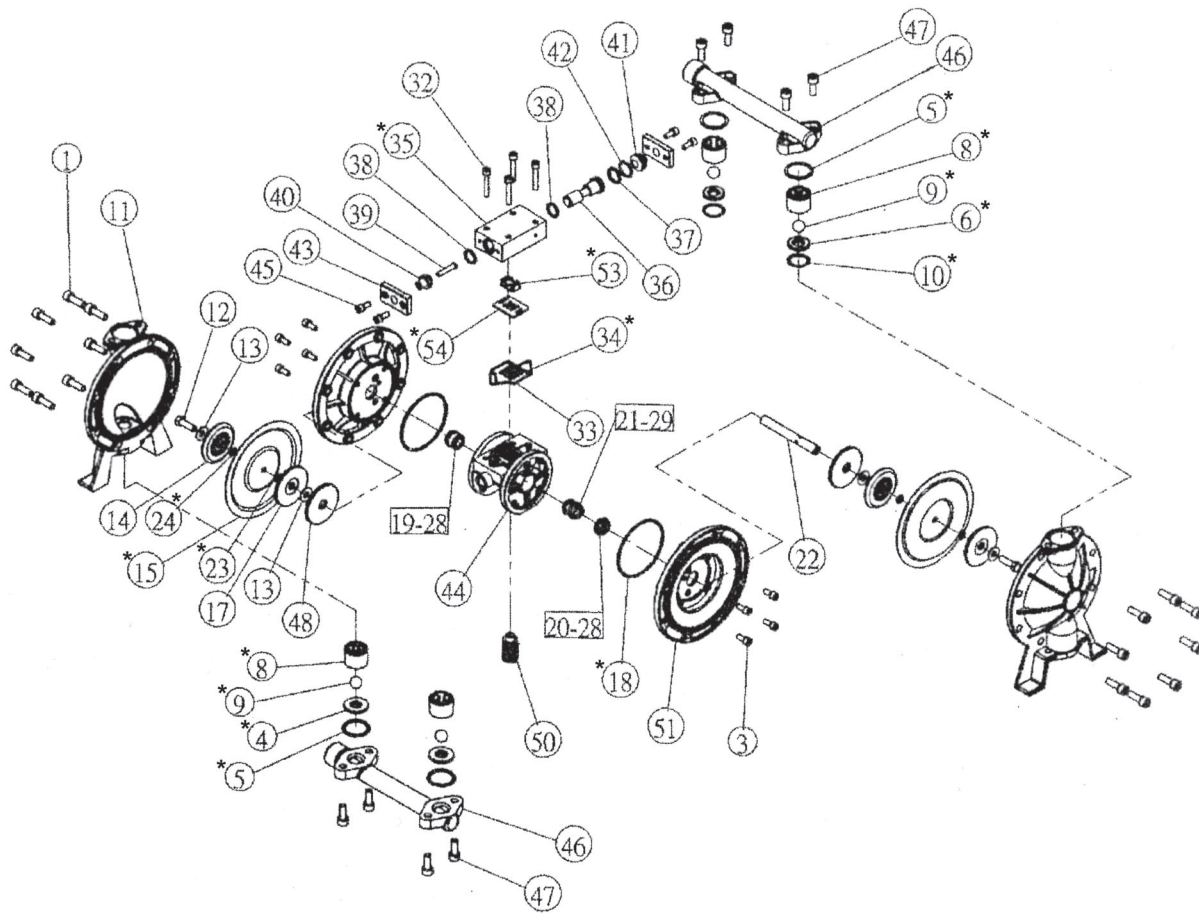

*Indicates part included in repair kit # 10-159

ITEM NO.	QTY.	PART NO.	DESCRIPTION	ITEM NO.	QTY.	PART NO.	DESCRIPTION
1	16	PC000018SW	Hex Screw	24	2	PB000001	O-Ring
3	8	PC000004SW	Hex Screw	32	4	PC000005SW	Hex Screw
4	2	PA000015	Lower Ball Seat	33	1	PD000140	O-Ring
5	4	PB000083	O-Ring	34	1	PD000139	O-Ring
6	2	PA000025	Upper Ball Seat	35	1	PA000102	Air Valve Body
8	4	PB000129	Ball Cage (TSS)	36	1	PA000141	Air Valve Piston
	4	PB000127	Ball Cage (TTS)	37	1	PDAP0023	O-Ring
9	4	PA000001	SS Ball (TSS)	38	2	PDR00016	O-Ring
	4	PB000039	Teflon Ball (TTS)	39	1	PA000112	Copper Latch
10	2	PB000013	Pad	40	1	PD000080	Air Valve Cover
11	2	PA000048	Pump Chamber	41	1	PB000021	Air Valve Cover
12	2	PC000025	Steel Hex Screw	42	1	PD000030	O-Ring
13	4	PC000057	Steel Washer	43	2	PA000117	Air Valve Housing
14	2	PA000060	Diaphragm Pad	44	1	PA000143	Cylinder Body
15	2	PB000026	Diaphragm Pad	45	4	PC000004SW	Air Valve Plate
17	2	PA000059	Diaphragm Pad	46	2	PA000128	Pipe
18	2	PD000011	O-Ring	47	8	PC000015SW	Hex Screw
19-28	1	A16-19-28	Shaft Cover	48	2	PD000056	Diaphragm Plate
20-28	1	A16-20-28	Shaft Cover	50	1	PB000046	Muffler
21-29	1	A16-21-29	Axis Switch	51	2	PA000215	Air Chamber
22	1	PA000114	Diaphragm Shaft	53	1	PB000334	Valve Insert
23	2	PD000001	O-Ring	54	1	PB000072	Divider

CAT DOUBLE DIAPHRAGM PUMPS

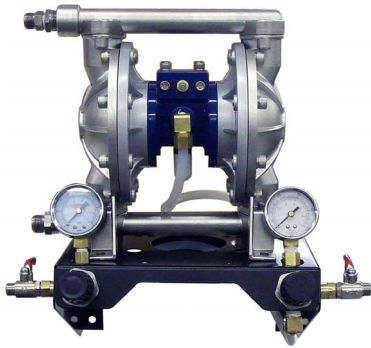

**70-1101
DD Pump
Wall Mount**



**70-1102
DD Pump
Cart Mount**



**70-1105
DD Pump
55 Gal Cover
Mount
70-1104
With Agitator**

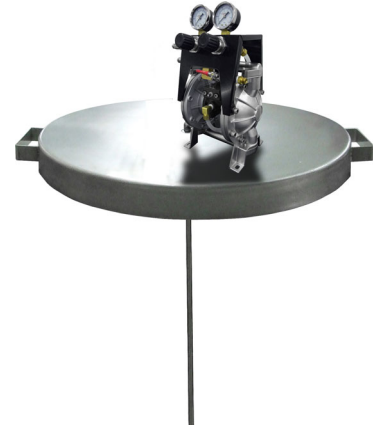

**70-1105
DD Pump
55 Gal Drum
Mount
70-1106
With Agitator**

Accessories



**Color Change Manifold
70-266SS
(1/2" Stainless)**



**Fluid Regulator
52-203**



**Siphon Hose Assy
74-538 - 3/8"x3'
74-520 - 1/2"x3'
74-524 - 1/2"x5'**



**Pulse Chamber
70-271**