

AIRMIX® PUMP

20-25

Disassembly / Reassembly

TRANSLATION OF THE ORIGINAL MANUAL

IMPORTANT : Before assembly and start-up, please read and clearly understand all the documents relating to this equipment (professional use only).

THE PICTURES AND DRAWINGS ARE NON CONTRACTUAL. WE RESERVE THE RIGHT TO MAKE CHANGES WITHOUT PRIOR NOTICE.

KREMLIN - REXSON

150, avenue de Stalingrad
93 245 - STAINS CEDEX – France

☎ : 33 (0)1 49 40 25 25 Fax : 33 (0)1 48 26 07 16

www.kremlin-rexson.com



CAUTION :

Before any action on the pump, shut off the compressed air supply and depressurize the system.

The pump is manufactured under the ATEX agreement and can not be modified. KREMLIN REXSON will not be held responsible for any failure to comply with that instruction.

Guards (air motor cover, coupling shields, housings ...) have been designed for safe use of the equipment.

The manufacturer will not be held responsible for bodily injury or failure and / or damage to property due to removal or partial removal of the guards

▪ **SUCTION VALVE (REFER TO DOC. 573.032.050)**

Unscrew the suction valve (5) by holding cylinder (2).

The ball (10) is secured on the valve (5) by means of a circlips (9).

Clean the parts.

Reinstall the suction valve and the seal (25). Replace them if necessary.

▪ **EXHAUST VALVE**

Unscrew cylinder (2) and pull it downwards.

Unscrew exhaust valve (6) by holding piston (3).

Remove ball (15).

Clean the parts and reinstall them. Be certain seal (8) is installed. Replace the parts if necessary.

▪ **LOWER MOBILE PACKING**

Unscrew cylinder (2) and pull it downwards.

Unscrew stuffing-box (7) to release GT seal (13) from exhaust valve (6).

Remount the parts in reverse order.

For that :

- Install the GT seal onto exhaust valve (6).

- Screw stuffing-box (7).

- The seal must be blocked by screwing mobile stuffing-box (7) onto exhaust valve (6).

If necessary replace seal (8) when reinstalling cylinder (2).

▪ **UPPER PACKING**

Separate the piston rod from the motor and the piston (3) from the fluid section.

Unscrew wetting-cup (4) by means of the wrench supplied with the pump.

Pull piston (3) upwards to remove upper packing seals (21 and 22).

Reinstall parts in reverse order. Be certain seals (21 and 22) are installed properly (**direction**, **order** and assembly **dimension**).

Tighten wetting-cup (4).

After reassembly, fill up the pump with solvent and increase pressure to maximum in the fluid section. Then stop the pump and open exhaust valve to depressurize.

Retighten wetting-cup (4) by means of the wrench, in order to be in accordance with the opposite drawing.

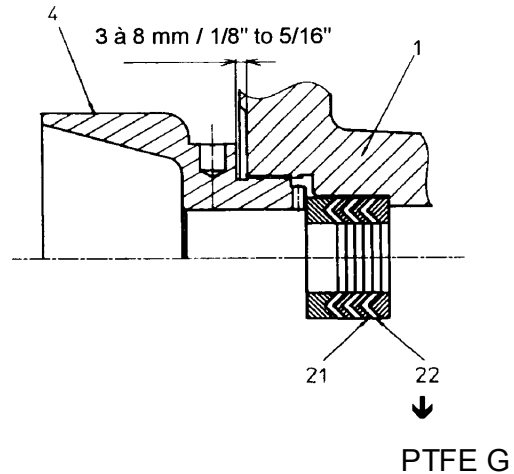

▪ **REVERSING BLOCK (MOTOR) (REFER TO DOC. 573.087.040)**

Guards (air motor cover, coupling shields, housings ...) have been designed for safe use of the equipment.

The manufacturer will not be held responsible for bodily injury or failure and / or damage to property due to removal or partial removal of the guards

Disassemble cover by removing the screw.

Dissociate female yoke from reversing block lever.

Dismount reversing block by removing screws.

Reinstall the new reversing block in the reverse order of the disassembly sequence.

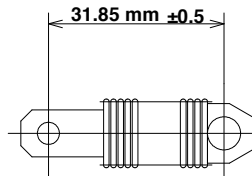

➡ **CAUTION :** The number of spirals must equally be distributed on each fastening parts in order to get the above dimension.

Before reassembling the different components :

- Clean the parts with the appropriate cleaning solvent.
- Install new seals if it is necessary after having lubricated them with PTFE grease.
- Install new parts if it is necessary.

