

Festool GmbH
Wertstraße 20
73240 Wendlingen
Germany

www.festoolusa.com

DISTRIBUTED BY:
Pro Wood Finishes
14622 Southlawn Lane
Rockville MD 20850
Ph: (301) 424-3033

FESTOOL

Instruction manual

Page 6

IMPORTANT: Read all instructions before using.

Guide d'utilisation

Page 17

IMPORTANT: Lire toutes les instructions avant de démarrer les travaux.

Manual de instrucciones

Página 29

IMPORTANTE: Lea todas las instrucciones antes de usar.

**Instruction manual
Guide d'utilisation
Manual de instrucciones**

CT 36 E AC



702675_008



1

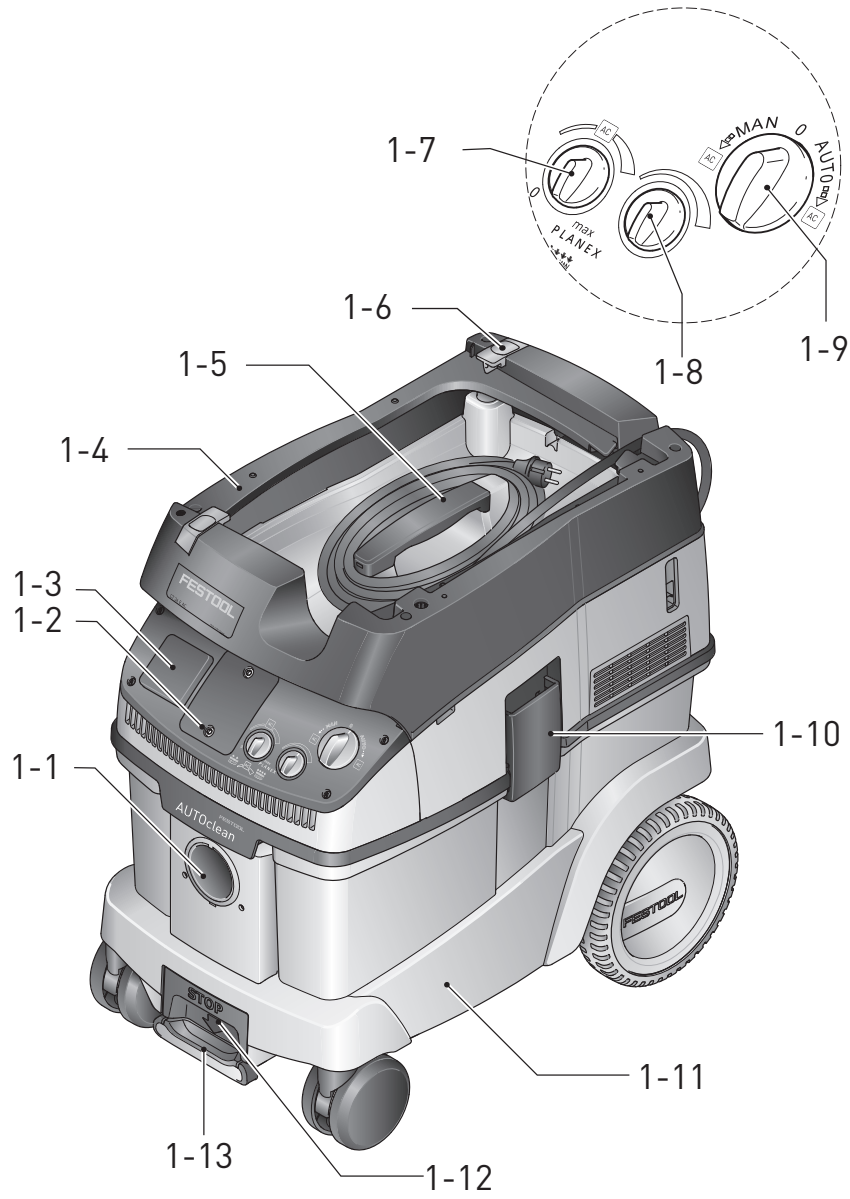

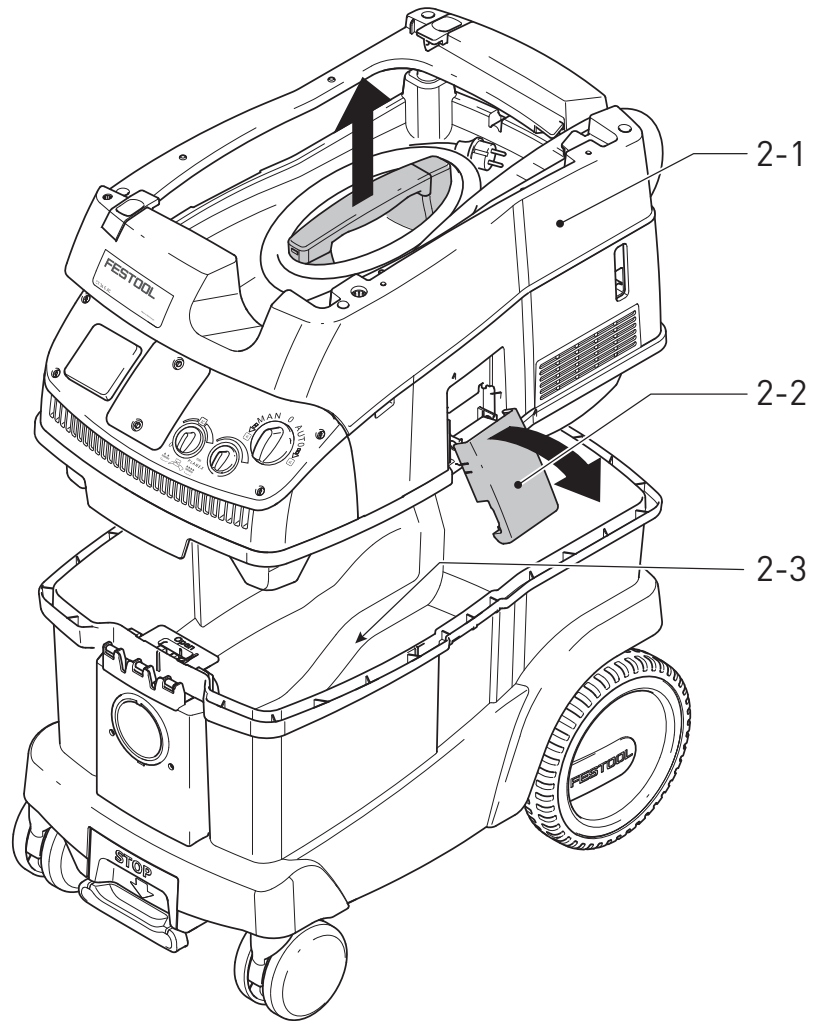

2







Contents

Symbols	6
About this manual.....	6
Safety instructions.....	7
Technical data.....	9
Functional description.....	9
Intended use	9
Operation	10
Settings.....	11
Working.....	12
Filter.....	13
After finishing work	15
Service and maintenance	16
Accessories.....	16
Disposal	16

Symbols



Sym- bol	Significance
	Warning of general danger
	Risk of electric shock
	Read operating instructions and safety notices!



Sym- bol	Significance
	Wear a dust mask.
	Tip or advice
	Handling instruction
W	watt
h	hour
min	minutes
s	seconds
kg	kilograms
Pa	pascal
dB	decibel
V	volts
A	amperes
Hz	hertz
~ a.c.	alternating current
--- d.c.	direct current
n_0	no load speed
	Class II construction
rpm min ⁻¹	revolutions per minute
"	inch
lbs.	pound
\varnothing	diameter

About this manual

Save these instructions

It is important for you to read and understand this manual. The information it contains relates to protecting **your safety** and **preventing problems**. The symbols below are used to help you recognize this information.

	DANGER	Description of imminent hazard and failure to avoid hazard will result in death.
	WARNING	Description of hazard and possible resulting injures or death.
	CAUTION	Description of hazard and possible resulting injuries.

	NOTICE	Statement including nature of hazard and possible result.
	HINT	Indicates information, notes, or tips for improving your success using the tool.

Safety instructions



IMPORTANT SAFETY INSTRUCTIONS

When using an electrical appliance, basic precautions should always be followed, including the following:

READ ALL INSTRUCTIONS

BEFORE USING THIS DUST EXTRACTOR:



WARNING - To reduce the risk of fire, electric shock, or injury:

- Do not leave the dust extractor when plugged in. Unplug from outlet when not in use and before servicing.
- Use indoors only.
- Do not allow to be used as a toy. Close attention is necessary when used by or near children.
- Use only as describes in this manual. Use only manufacturer's recommended attachments.
- Do not use with damaged cord or plug. If the dust extractor is not working as it should, has been dropped, damaged, left outdoors, or dropped into water, return it to a service center.
- Do not pull or carry by cord, use cord as a handle, close a door on cord, or pull cord around sharp edges or corners. Do not run dust extractor over cord. Keep cord away from heated surfaces.
- Do not unplug by pulling on cord. To unplug, grasp the plug, not the cord.
- Do not handle plug or dust extractor with wet hands.
- Do not put any object into openings. Do not use with any opening blocked; keep free of dust, lint, hair, and anything that may reduce air flow.
- Keep hair, loose clothing, fingers, and all parts of body away from openings and moving parts.
- Turn off all controls before unplugging.
- Use extra care when cleaning on stairs.
- Do not use to pick up flammable or combustible liquids, such as gasoline, or use in areas where they may be present.
- Connect to a properly grounded outlet only. See Grounding instructions.
- Do not pick up anything that is burning or smoking, such as cigarettes, matches, or hot ashes, hot chips or particles, sparks.
- Do not use without dust bag and/or filters in place.

SAVE THESE INSTRUCTIONS

GROUNDING INSTRUCTIONS

This appliance must be grounded. If it should malfunction or breakdown, grounding provides a path of least resistance for electric current to reduce the risk of electric shock. This dust extractor is equipped with a cord having an equipment-grounding conductor and grounding plug. The plug must be inserted into an appropriate outlet that is properly installed and grounded in accordance with all local codes and ordinances.

 **WARNING** - Improper connection of the equipment grounding conductor can result in a risk of electric shock. Check with a qualified electrician or service person if you are in doubt as to whether the outlet is properly grounded. Do not modify the plug provided with the dust extractor - if it will not fit the outlet, have a proper outlet installed by a qualified electrician.

This appliance is for use on a nominal 120-V circuit and has a grounding attachment plug that looks like the plug illustrated in sketch A in Figure beside.

GROUNDING METHODS - SKETCH A

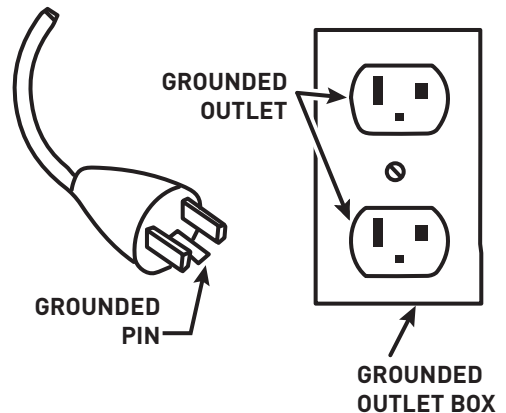

Make sure that the appliance is connected to an outlet having the same configuration as the plug. No adaptor should be used with this appliance.

Polarization Instructions

To reduce the risk of electric shock, this vacuum cleaner has a polarized plug (one blade is wider than the other). This plug will fit in a polarized outlet only one way. If the plug does not fit fully in the

outlet, reverse the plug. If it still does not fit, contact a qualified electrician to install the proper outlet. Do not change the plug in any way.

Further safety instructions

- This appliance must not be used by persons (including children) with reduced physical, sensory or mental capabilities, or lack of experience and knowledge. **Children** need to be supervised to ensure they do not play with the appliance.



CAUTION

**This machine is for indoor use only.
This machine shall be stored indoors only.**

Health hazard by dust

 **WARNING!** Various dust created by power sanding, sawing, grinding, drilling and other construction activities contains chemicals known (to the State of California) to cause cancer, birth defects or other reproductive harm. Some examples of these chemicals are:

- lead from lead-based paints,
- crystalline silica from bricks and cement and other masonry products, and
- arsenic and chromium from chemically treated lumber.



The risk from these exposures varies, depending on how often you do this type of work. To reduce your exposure to these chemicals: work in a well ventilated area, and work with approved safety equipment, such as dust masks that are specially designed to filter out microscopic particles. Wash hands after handling.



WARNING

TO REDUCE THE RISK OF INJURY, USER MUST READ INSTRUCTION MANUAL.

Technical data

Dust extractor CT 36 E AC

Power consumption (dust extractor only)		2.9 - 8.3 A (350 - 1000 W) ^{1.)}
Total connected load	max.	12 A (1440 W)
Max. rating of connected Power Tool		3.7 A ^{2.)}
Volume flow (air), turbine	max.	234 m ³ /h (8264 cu.ft./h)
Vacuum, turbine	max.	24000 Pa
Filter surface		6318 cm ² (979.3 sq.in.)
Suction hose (diameter x length)		36 mm x 3.5 m (1-7/16" x 11.5')
Protection type		IP X4
Sound pressure level as per IEC 60704-2-1		71 dB(A)
Container capacity	CT 36 E AC	36 l (9.5 gal.)
Dimensions L x W x H	CT 36 E AC	630 x 365 x 596 mm (24.8 in. x 14.4 in. x 23.4 in.)
Weight	CT 36 E AC	15.2 kg (33.5 lbs)

^{1.)} 8.3 A (1000 W) is the medium value for different operation conditions, a maximum power consumption of 10 A (1200 W) is possible.

^{2.)} When the suction power adjuster [1-7] is adjusted to the lowest suction power (see page 11, chapter Settings - Adjusting the suction power) the maximal rating of a connected power tool can be 9.1 Amps.

Functional description

The pictures for the functional description are on a fold-out page at the beginning of the instruction manual. When reading of the manual you can fold out this page for having always an overview of the machine.

Accessories shown or described are sometimes not included in the scope of delivery.

[1-1] Intake opening

[1-2] Module slot

[1-3] Appliance socket

[1-4] Hose store

[1-5] Handle

[1-6] SysDoc

[1-7] Automatic cleaning

[1-8] Suction power adjuster

[1-9] Switch

[1-10] Locking clip

[1-11] Dust container

[1-13] Brake

Intended use

The dust extractor is designed for use as specified for the aspiration and evacuation of non-noxious dusts, dirt, sand, shavings etc..

The dust extractor is designed as specified for vacuuming water.

The dust extractor is designed for household, com-

mercial or both use.



WARNING

The user will be liable for damage due to improper use.

Operation



WARNING

Unauthorised voltage or frequency!

Risk of accident

- ▶ The mains voltage and the frequency of the power source must correspond with the specifications on the machine's name plate.
- ▶ In North America, only Festool machines with the voltage specifications 120 V/60 Hz may be used.

Consider the pictures on the fold-out page.

Initial operation

- ▶ Open the locking clips **[2-2]** and remove the top section of the machine **[2-1]**.
- ▶ Remove the accessories from the dust container **[2-3]** and the packaging!
- ▶ Insert a filter or disposal bag in the dirt trap (see chapter Changing the filter bag and Changing the disposal bag).
- ▶ Attach the cable holder to the rear of the mobile dust extractor (see Fig. **[3]**).

3

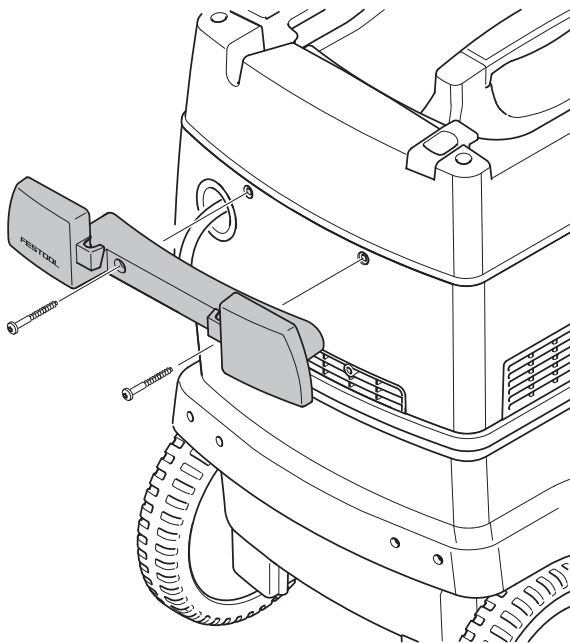

- ▶ Replace the top section **[2-1]** and close the locking clips **[2-2]**.

- ▶ Connect the suction hose to the machine.

Switch on/off

- ▶ Insert the plug into an earthed socket.



CAUTION

Risk of injury from tools starting up unexpectedly

- ▶ Before setting the switch to the "AUTO" or "MAN" position, make sure that the connected tool is switched off.

The switch **[1-9]** serves as an On/Off switch. It has three positions:

Switch position "0"

Appliance socket **[1-3]** is disconnected from the power, mobile dust extractor is switched off.

"MAN" switch position

Appliance socket **[1-3]** is disconnected from the power, the mobile dust extractor starts.

"Auto" switch position

Appliance socket **[1-3]** is connected to the power, the mobile dust extractor starts when the connected tool is switched on.

Extension Cord

If an extension cord is required, it must have sufficient cross-section to prevent an excessive drop in voltage or overheating. An excessive drop in voltage reduces the output and can lead to failure of the motor. The table below shows you the correct cord diameter as a function of the cord length for this tool.

Total Extension Cord Length (feet)	25	50	100	150
Cable size (AWG)	14	12	not recommended	

Use only U.L. and CSA listed extension cords.

Never use two extension cords together. Instead, use one long one.

- ① The lower the AWG number, the stronger the cord.

The antistatic system

Friction inside the extraction hose causes static electricity to develop during extraction. Operating personnel may receive unpleasant electric shocks

while working. The mobile dust extractor is fitted with an antistatic system as standard to discharge any static electricity that may develop. However, always use the enclosed antistatic extraction hose.

Settings

Consider the pictures on the fold-out page.

Connecting electric power tools



WARNING

Risk of injury

- ▶ Observe the maximum appliance socket connected load (see chapter "Technical data")
 - ▶ Switch off the electric power tool.
-
- ▶ Connect the electric power tool to the appliance socket **[1-3]**.

Connecting pneumatic tools



WARNING

Risk of injury

- ▶ Make sure that the pneumatic tool is switched off before connecting or disconnecting.

If the compressed air module **[1-2]** (496141) is installed, the automatic switch-on function of the mobile dust extractor also works in combination with pneumatic tools.

We also recommend installing the VE service unit (495886). The service unit filters and lubricates the compressed air and enables an adjustment of the

air pressure. An IAS adapter (454757) is available to connect Festool pneumatic tools to the IAS system.

The operating pressure of the tool must be 6 bar for the automatic switch-on unit to function correctly.

Temperature cut-out

To prevent overheating, a temperature cut-out switches the mobile dust extractor off when it reaches a critical temperature.

- ▶ Switch off the mobile dust extractor and allow to cool for about 5 minutes.
- ⓘ If the mobile dust extractor will not switch on again, please contact a Festool service workshop.

Adjusting the suction power

You can use the suction power adjuster **[1-8]** to adapt the machine suction power to different applications.

AUTOclean - Cleaning the main filter

To maintain a constant suction power when extracting fine dust, you can adjust the frequency of the automatic **[1-7]** cleaning system in infinite variables using the rotary knob. Always use the automatic cleaning system in combination with a disposal bag.



Before performing wet extraction tasks or working with a filter bag, set the **[1-7]** rotary knob to position 0.

- ▶ Set the automatic cleaning function to the highest setting when **[1-7]** extracting large quantities of dust.

Manual cleaning



If the suction power decreases, cleaning can be started manually by turning the switch **[1-9]** to the **AC** symbol positioned on either side of the switch.

We recommend cleaning the main filter completely if severely clogged:

- ▶ Cover the end of the nozzle or suction hose with your hand for 2 seconds.
- ▶ Turn the switch [1-9] to the **AC** symbol.
- ④ When the CT-VS closing slide is used (order no.: 497926), the filter can be cleaned fully without removing the connected electric power tools.

In intensive applications that generate adherent dust, it may be necessary to clean the filter element

mechanically under certain circumstances (extract). Wear a dust mask!

Applying the brake

Folding out the brake lever [1-13] prevents the mobile dust extractor from rolling. To achieve this, lift the front end of the mobile dust extractor slightly and push the brake lever downwards until it latches into place. Push the lever [1-12] again to release.

Working

Handling

Hose store: after finishing work, you can feed the suction hose through the recess [4-3] and place it in the hose store. You can do the same with the mains cable through the other recess [4-2].

SysDoc Systainer attachment system: a Systainer can be attached to the storage area via the two slides [4-1].

4

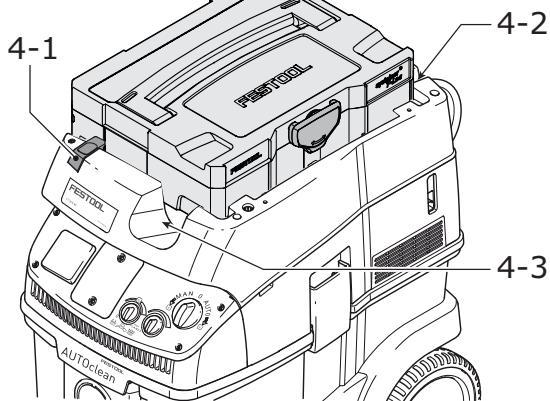

Extracting dry materials



WARNING

Not suitable to vacuum hazardous or toxic substances or dusts e.g. asbestos.

- ▶ The filters will not be able to capture all particles and may exhaust them back into the environment.

Remember: A damp main filter will clog more quickly when dry materials are extracted. Therefore, dry the main filter before extracting dust or replace the damp filter with a dry one.

Extracting fluids



WARNING

Risk of injury

- ▶ Do not evacuate combustible liquids!

- ④ The main filter shall only be used for extracting dry materials.

Before extracting fluids, remove the filter or disposal bag (see chapter Changing the filter bag and Changing the disposal bag). We recommend using a special wet filter.

The dust extractor stops automatically when the maximum level is reached.



CAUTION

Escaping foam and fluids

- ▶ Switch off the machine immediately and empty the dust container.

Special features of the CT 36 E AC- LHS

To use the mobile dust extractor in combination with the PLANEX:

- ▶ Use kink-resistant suction hose D 36 mm x 3.5 m-AS.
- ▶ Use a special suction sleeve for connecting the PLANEX.
- ▶ Use closing slide CT-VS between the intake opening [1-1] and suction hose.
- ▶ Attach the tool holder.
- ▶ **Always use with a disposal bag!**

Filter



WARNING

Risk of injury

- ▶ During the following procedure, take care not to raise dust more than is unavoidable. Moisten the main filter with a water spray before removing it.

Changing the filter bag

Inserting the filter bag

- ▶ Open the locking clips [2-2] and remove the top section of the machine [2-1].
- ▶ Insert a new filter bag (SC-FIS-CT 26/36/48) (Fig. [5]) in the inlet port of the dust container and interlock it. **Important:** be aware that the locking engages.
- ① Make sure that the filter bag is not pinched between the top and bottom sections.
- ▶ Replace the top section [2-1] and close the locking clips [2-2].

SC-FIS-CT 26/36/48

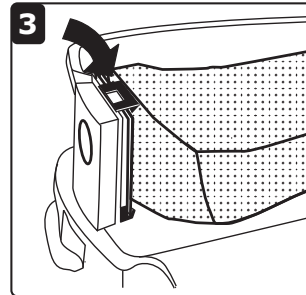
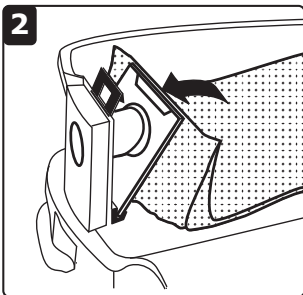
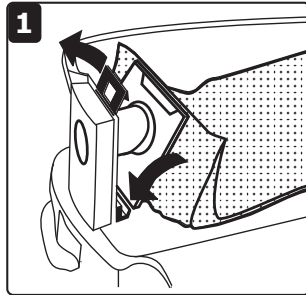
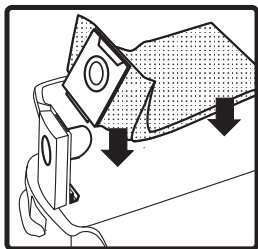

5

Removing the filter bag

- ▶ Open the locking clips [2-2] and remove the top section of the machine [2-1].

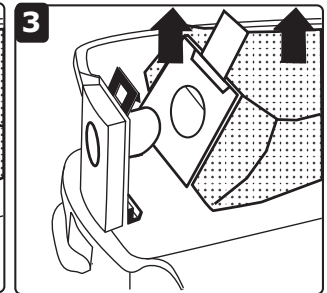
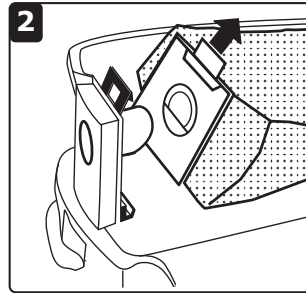
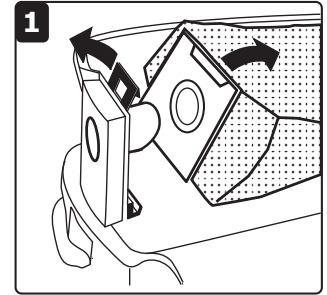
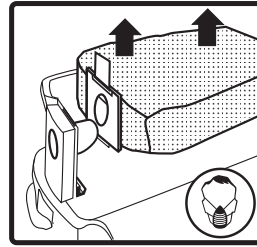

6

- ▶ Remove the filter bag (Fig. [6]).
- ▶ Dispose of the used bag in accordance with statutory regulations.
- ▶ Clean the dust container [2-3].
- ▶ Insert a new filter bag if necessary (see Inserting the filter bag).
- ▶ Replace the top section [2-1] and close the locking clips [2-2].

Changing the disposal bag

Inserting the disposal bag [7]

- ▶ Open the locking clips [2-2] and remove the top section of the machine [2-1].
- ▶ Insert a new disposal bag (ENS-CT26/36/48) on the inlet nozzle of the container and lock in position.

Important: The lateral openings on the disposal bag must be positioned inside the container. Make sure that the bolt engages.

- ▶ Place the disposal bag over the edge of the container.



Make sure that the contacts [7-1] are free.

- ▶ Replace the top section [2-1] and close the

locking clips [2-2].

ENS-CT 26/36/48

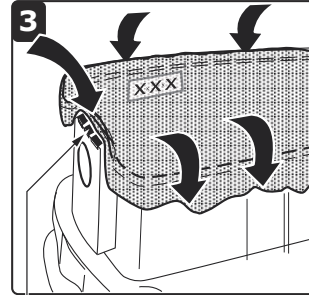
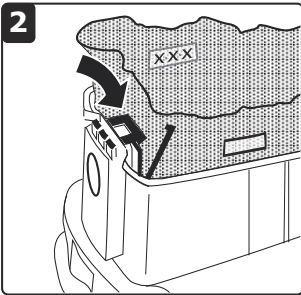
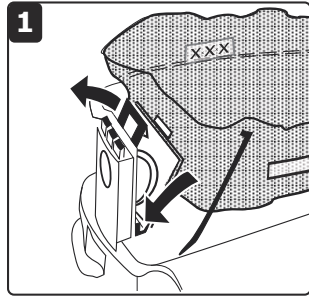
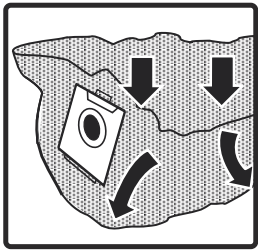

7

7-1

Removing the disposal bag [8]

- ▶ Open the locking clips [2-2] and remove the top section of the machine [2-1].
- ▶ Close the disposal bag.
- ▶ Remove the disposal bag.
- ▶ Dispose of the used disposal bag in accordance with statutory regulations.
- ▶ Clean the dust container [2-3].
- ▶ Replace the top section [2-1] and close the locking clips [2-2].

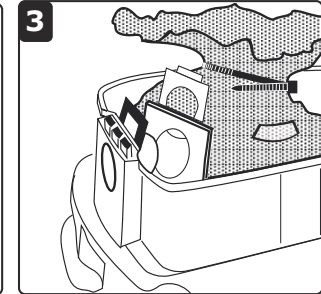
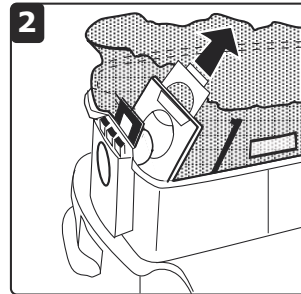
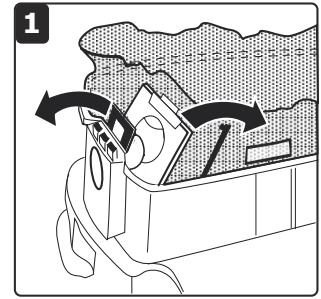
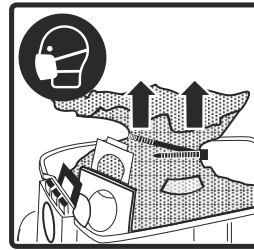

8

Changing the main filter

NOTE

Motor damage

- ▶ Never operate the extractor without a main filter fitted as the motor may become damaged.
- ▶ Open the locking clips [2-2] and remove the top section of the machine [2-1].
- ▶ Turn the top section of the machine so that the main filter is facing upwards (Fig.[9]).
- ▶ Fold over the lever [9-3] and remove the retainer [9-2].
- ▶ Remove the used main filter [9-1] and replace with a new one.
- ▶ Dispose of the used main filter in accordance with statutory regulations.
- ▶ Insert the retainer [9-2] and fold over the lever [9-3] until it engages.
- ▶ Replace the top section [2-1] and close the

locking clips [2-2].

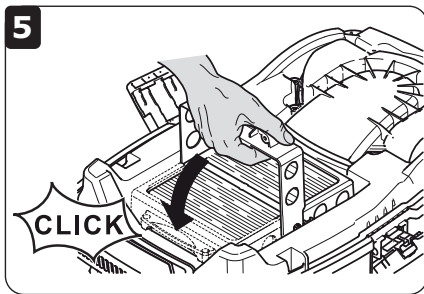
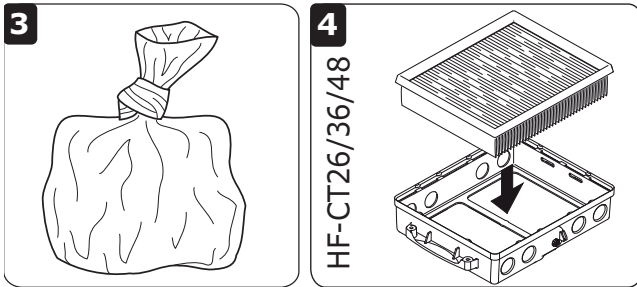
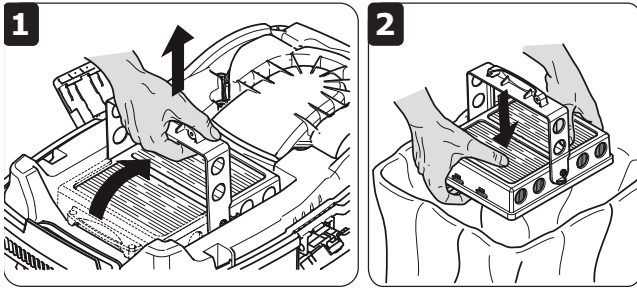
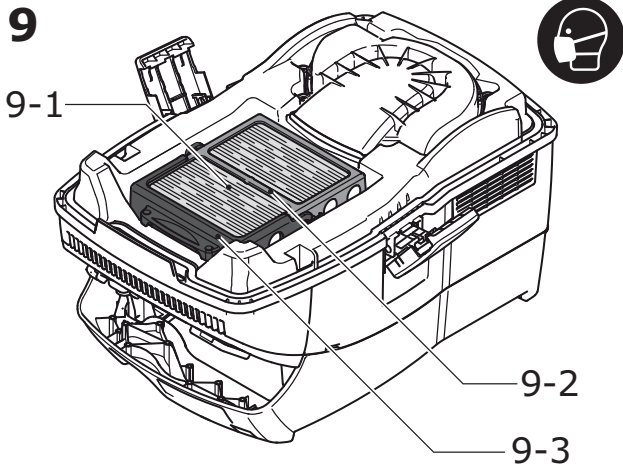

After finishing work

- ▶ Switch off the mobile dust extractor and disconnect the plug.
- ▶ Wind up the mains power cable.
- ▶ Empty the dust container.



CAUTION

Hazardous dust

Damage to the respiratory passage

- ▶ Wipe down the mobile dust extractor and clean all accessories thoroughly using the extractor (inside and out) before removing from the working area.
 - ▶ Parts that you were not able to clean thoroughly must be sealed in an airtight plastic bag prior to transportation.
 - ▶ Wear a dust mask!
- ▶ Place the mobile dust extractor in a dry room inaccessible to unauthorised users.

Emptying the dust container

The dust container [2-3] can be emptied once the top section has been removed.

- ▶ After extracting fluids, clean the fill level sensors [10-1] regularly with a soft cloth and inspect for damage.

10

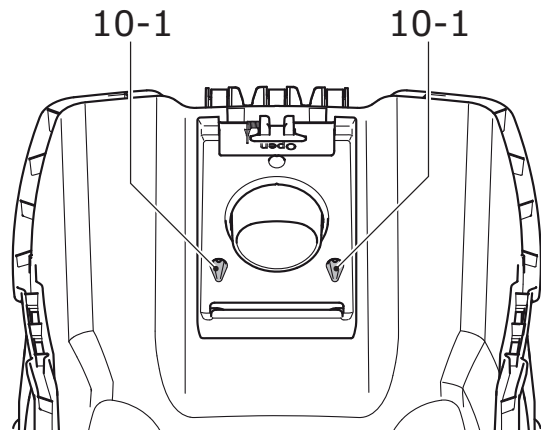

Service and maintenance



WARNING

Any maintenance or repair work that requires opening of the motor or gear housing should only be carried out by an authorised Customer Service Centre (name supplied by your dealer)!

- ▶ Maintenance or repair work carried out by an unauthorised person can lead to the wrong connection of the power leads or other components, which in turn can lead to accidents with serious consequences.



WARNING

To prevent accidents, always remove the plug from the power supply socket before carrying out any maintenance or repair work on the tool!

- ▶ Do not use compressed air to clean the electrical tool! Do not try to clean parts inside the tool in this way, as you could let foreign objects in through the openings of the tool housing.

A dust test must be performed at least once a year by the manufacturer or an instructed person. This test may include checks to determine whether the filter is damaged, the machine is sealed properly and the monitoring features are functioning correctly.

During maintenance and repair work, all components that cannot be cleaned satisfactorily must be replaced. The old components must be sealed in impermeable plastic bags prior to disposal in compliance with applicable regulations for this type of waste.



Customer service and repair only through manufacturer or service workshops: Please find the nearest address at:

www.festoolusa.com/service



Use only original Festool spare parts!
Order No. at:

www.festoolusa.com/service

Accessories

Use only original Festool accessories and Festool consumable material intended for this machine because these components are designed specifically for the machine. Using accessories and consumable material from other suppliers will most likely affect the quality of your working results and limit any warranty claims. Machine wear or your own personal workload may increase depending on the application.

Protect yourself and your machine, and preserve your warranty claims by always using original Festool accessories and Festool consumable material!

The accessory and tool order number can be found in the Festool catalog or on the Internet under www.festoolusa.com.

Disposal

Do not throw the tool in your household waste!
Dispose of machines, accessories and packaging at

an environmentally responsible recycling centre. Observe the valid national regulations.