



## ATD-10511 7" Shop Polisher with Soft Start Owner's Manual



 Double insulation



### Features:

- Dependability, lightweight and performance have made this one of the most popular polishers in the industry
- Powerful 11 Amp motor with ball bearing construction for long life
- Variable dial speed control from 1,000 to 3,000 rpm
- Includes both D-handle & Side Handle for comfortable horizontal & vertical use
- Easily converts to a sander with enclosed Velcro® Pad
- External brush caps for easy servicing
- Spindle lock for easy pad changing

### Includes:

- |                 |                          |
|-----------------|--------------------------|
| (1) Rubber Pad  | (1) D-Handle             |
| (1) Velcro® Pad | (1) Spanner Wrench       |
| (1) Wool Bonnet | (1) Hex Key Wrench       |
| (1) Side Handle | (1) Set of Extra Brushes |

## WARNING

**WARNING:** This product contains chemicals, including lead, known to the State of California to cause cancer, birth defects or other reproductive harm. *Wash hands after handling.*

## **READ ALL INSTRUCTIONS BEFORE OPERATING**

### **SAVE THESE INSTRUCTIONS**

Thank you for purchasing 7" Polisher. Before attempting to operate your new Polisher please read these instructions thoroughly. You will need these instructions for the safety warnings, precautions, assembly, operation, maintenance procedures, parts list and diagrams. Keep the instructions and invoice in a safe, dry place for future reference.

### **WARNING: When using electric tools, machines or equipment, basic safety precautions should always be followed to**

**reduce the risk of fire, electric shock, and personal injury.** The warnings, cautions and instructions discussed in this instruction manual cannot cover all possible conditions or situations that could occur. It must be understood by the operator that common sense and caution are factors which cannot be built into this product, but must be supplied by the operator.

## **SPECIFICATIONS**

Motor..... 120V ~ 60Hz 11Amp  
No Load Speed.....1000 - 3000 RPM  
Weight.....7 lbs  
Spindle Thread..... 5/8" - 11  
Spindle Lock.....Yes  
Trigger Lock.....Yes

## **SAFETY RULES**

1. Know your machine. Read this manual carefully. Learn the machine's applications and limitations, as well as specific potential hazards peculiar to it.
2. Ground all machines. This machine is "Double Insulated," meaning that all outside metal parts are insulated from electrical power. Double Insulated tools are equipped with a polarized plug. This plug will fit in a polarized outlet only one way. If the plug does not fit fully in the outlet, reverse the plug. If it still does not fit, contact a qualified electrician to install a polarized outlet. Do not attempt to circumvent this safety feature.
3. Do not expose tool to moisture. Don't use this machinery in damp or wet locations. Keep out of rain.
4. Keep work area clean. Cluttered areas invite injuries.
5. Keep children away. All children should be kept away from the work area. Never let a child handle a tool without strict adult supervision.
6. Do not operate this tool if under the influence of alcohol or drugs. Read warning labels on prescriptions to determine if your judgment or reflexes are impaired while taking drugs. If there is any doubt, do not attempt to operate.
7. Use safety equipment. Eye protection should be worn at all times when operating this machine. Use ANSI approved safety glasses. Everyday eyeglasses only have impact resistance lenses. They are NOT safety glasses. Dust mask, respirator, non-skid safety shoes, hard hat, or hearing protection must be used in appropriate conditions.

8. Wear proper apparel. Loose clothing, gloves, neckties, rings, bracelets, or other jewelry may present a potential hazard when operating this machine. Please keep all apparel clear of the machine.
9. Don't overreach. Keep proper footing and balance at all times when operating this product.
10. Always disconnect the machine from the power supply before servicing or changing accessories.
11. Check for damage. Check your tool regularly. If part of the tool is damaged it should be carefully inspected to make sure that it can perform its' intended function correctly. If in doubt, the part should be repaired. Refer all servicing to a qualified technician. Consult your dealer for advice.
12. Keep away from flammables. Do not attempt to operate this tool near flammables or combustibles. Failure to comply may cause serious injury or death.
13. Do not start tool while it is resting on materials. Always turn tool on BEFORE coming in contact with material surface.
14. Do not set tool down until it has come to a complete stop.
15. Always check to make sure that trigger lock is not engaged before plugging tool in.
16. Keep hands clear of cutting edges and all moving parts.
17. Protect others in work area from debris such as chips and sparks. Provide barriers and shields as needed.
18. Secure work. Use a clamp, vise or other practical means to hold your work securely, freeing both hands to control the tool.
19. Use the right tool for the job. Do not use a tool or attachment to do a job for which it was not intended. Do not alter a tool.
20. Use proper accessories. Using accessories no recommended may be hazardous. Be sure accessories are properly installed and maintained. Do not defeat a guard or othe safety device when installing an accessory or attachment.
21. Remove all adjusting keys and wrenches. Make a habit of checking that adjusting keys, wrenches, etc. are removed from the tool before turning it on.
22. Guard against electric shock. Prevent body contact with grounded surfaces such as pipes, radiators, ranges, and refrigerators. Hold your tool by insulated, non-metal grasping surfaces. Use a Ground Fault Circuit Interrupter (GFCI) to reduce shock hazards.
23. Avoid accidental starting. Be sure your tool is turned off before plugging it in. Do not use a tool if the power switch does not turn the tool on and off. Do not carry a plugged-in tool with your finger on the switch.
24. Do not force tool. Your tool will perform better at the rate for which it was designed. Excessive force only causes operator fatigue, increased wear and reduced control.
25. Do not abuse cord. Never carry your tool by its cord or unplug it by pulling the cord from the outlet. Pull the plug rather than the cord to reduce the risk of damage. Keep the cord away from heat, oil, sharp objects, cutting edges and moving parts.
26. Maintain tools carefully. Keep handles dry, clean and free from oil and grease. Periodically inspect tool cords and extension cords for damage. Refer all service to a qualified technician.
27. Store idle tools. When not in use, store your tool in a dry, secure place. Keep out of reach of children.

## SERVICE

1. Tool service must be performed only by qualified repair personnel. Service or maintenance performed by unqualified personnel could result in a risk of injury.
2. When servicing a tool, use only identical replacement parts. Follow instructions in the Maintenance section of this manual. Use of unauthorized parts or failure to follow Maintenance instructions may create a risk of electric shock or injury.

## SPECIFIC SAFETY RULES

1. Accessories must be rated for at least the speed recommended on the tool warning label. Wheels and other accessories running over rated speed can fly apart and cause injury.
2. Hold tool by insulated gripping surfaces when performing an operation where the polishing tool may contact hidden wiring or its own cord. Contact with a “live” wire will make exposed metal parts of the tool “live” and shock the operator.

## GETTING STARTED

Before operating your ATD-10511 7" Variable Speed Polisher, please check the contents of the box to make sure you have everything you will need.

### ACCESSORIES:

Straight Auxiliary handle	1 pc
D-shape Auxiliary handle	1 pc
Spanner	1 pc
Carbon Brush	1 set
Hex key wrench	1 pc
Rubber pad	1 pc
Velcro pad	1 pc
Wool bonnet	1 pc

## ASSEMBLY

1. Choose the most comfortable position for your side mount handle. Screw the handle securely into one of the two handle ports located at the base of the gear housing.
2. Make sure tool is unplugged and lay it on its back with the spindle upright.
3. Line up the notches on the inner ring of the rubber backing pad with the notches on the spindle. Securely slide rubber backing pad on to spindle.
4. Hand tighten spindle nut on to spindle threading.
5. Push in spindle lock button (located on the back side of the metal gear housing) and simultaneously tighten spindle nut with spanner wrench. Be sure to tighten nut securely.
6. After securing spindle nut, stretch polishing bonnet over the face of the rubber backing pad so that the bonnet wraps around the back of the pad.
7. Pull the fit adjusting string on the inside lip of the bonnet taut until all slack is removed and bonnet is snug against backing pad.
8. Tuck the fit adjusting string back inside bonnet so it will not interfere with bonnet surface during polishing. You are now ready to begin operation of your Polisher.

# OPERATING YOUR POLISHER

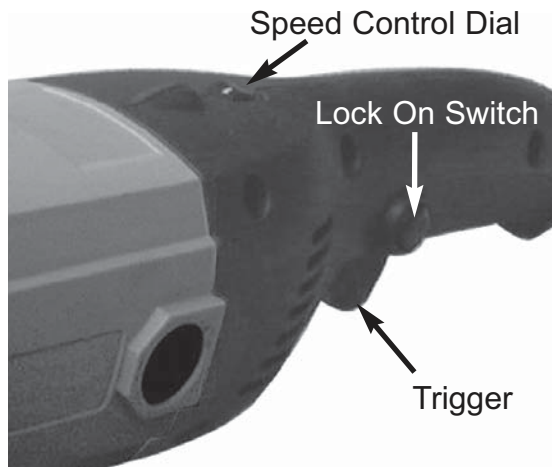

1. Plug Polisher into standard 110/120 Volt wall socket.
2. Prior to contact with material surface, pull trigger switch to ON position.
3. Evenly and carefully, lower polishing bonnet surface to material surface. Do not apply excessive pressure. Forcing the polisher down against your work surface puts unnecessary strain on the motor and will likely produce undesirable results in workmanship.
4. This Polisher features a speed control dial, which controls the polisher's maximum rotations per minute. The speed will remain at the chosen dial setting by use of the trigger switch. Dial settings range from 1 to 6. Lower numbers correspond to lower speeds and higher numbers correspond to higher speeds. Generally, lower speeds are recommended for tight work areas and higher speeds are ideal for large surface areas. Use the setting which best suits your job.
5. To control the speed, set the dial to the desired number and pull the trigger.
6. For extended work loads the Polisher is equipped with a "lock ON" switch. With trigger switch engaged, press lock switch with thumb. To release lock switch, press the trigger switch again.

7. When finished release trigger switch. Remember to let the polisher come to a complete stop before resting tool on any surface.

## MAINTENANCE

Keep your tool in good condition by adopting a regular maintenance program. Before use, examine the general condition of your tool. Inspect guards, switches, tool cord and extension cord for damage. Check for loose screws, misalignment, binding of moving parts, improper mounting, broken parts, and any other condition that may affect its' safe operation. If abnormal noise or vibration occurs, turn the tool off immediately and have the problem corrected before further use. Do not use a damaged tool.

**WARNING:** To reduce the risk of injury, always unplug your tool before performing any maintenance. Never disassemble the tool or try to do any rewiring on the tool's electrical system.

## CLEANING

Clean dust and debris from vents. Keep the tool handles clean, dry and free of oil or grease. Use only mild soap and damp cloth to clean your tool since certain cleaning agents and solvents are harmful to plastics and other insulated parts. Some of these harmful solvents include: gasoline, turpentine, lacquer thinner, paint thinner, chlorinated cleaning solvents, ammonia, and household detergents containing ammonia. Never use flammable or combustible solvents around tools.

**WARNING:** To reduce the risk of injury, electric shock and damage to the tool, never immerse your tool in liquid or allow liquid to flow inside the tool.



# ATD-10511

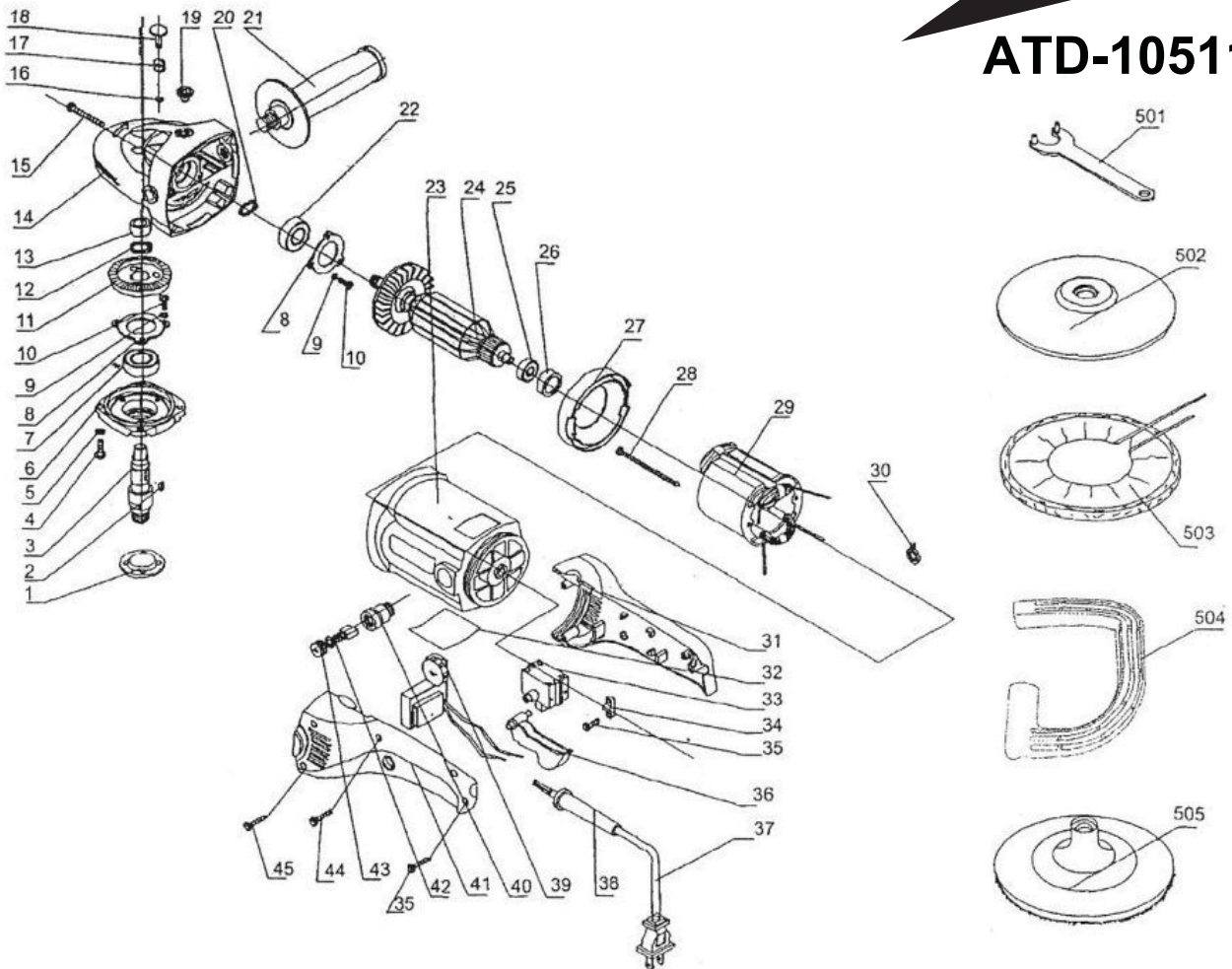

ITEM#	ORDERING PART#	PART DESCRIPTION
1	PRT10511-01	FLANGE NUT
2	PRT10511-02	KEY 4x5x13
3	PRT10511-03	SPINDLE
4	PRT10511-04	SCREW M5x16
5	PRT10511-05	SPRING WASHER 5
6	PRT10511-06	BEARING HOUSING
7	PRT10511-07	BEARING 6002.2Z
8	PRT10511-08	BEARING COVER
9	PRT10511-09	SPRING WASHER 4
10	PRT10511-10	SCREW M4x10
11	PRT10511-11	BIG GEAR
12	PRT10511-12	CIRCLIP FOR SHAFT
13	PRT10511-13	BRONZE BUSHING
14	PRT10511-14	GEAR BOX
15	PRT10511-15	SCREW ST5x45
16	PRT10511-16	E-RING 6
17	PRT10511-17	SPRING
18	PRT10511-18	BRAKE PIN
19	PRT10511-19	RUBBER PLUNGE
20	PRT10511-20	CIRCLIP FOR SHAFT
21	PRT10511-21	SIDE HANDLE
22	PRT10511-22	BEARING 6201.2Z
23	PRT10511-23	PLASTIC HOUSING
24	PRT10511-24	ARMATURE
25	PRT10511-25	BEARING 608.2Z
26	PRT10511-26	RUBBER BUSHING

ITEM#	ORDERING PART#	PART DESCRIPTION
27	PRT10511-27	GUIDE WIND CIRCLE
28	PRT10511-28	SCREW ST4.2x75
29	PRT10511-29	STATOR
30	PRT10511-30	TERMINAL
31	PRT10511-31	BLACK HANDLE (A)
32	PRT10511-32	NAMEPLATE
33	PRT10511-33	SWITCH
34	PRT10511-34	CORD CLIP
35	PRT10511-35	SCREW ST4.2x14
36	PRT10511-36	SWITCH PUSH BUTTON
37	PRT10511-37	CORD
38	PRT10511-38	RUBBER SLEEVE
39	PRT10511-39	TIMING SWITCH
40	PRT10511-40-43	BRUSH HOLDER W/CAP (PAIR)
41	PRT10511-41	BLACK HANDLE (B)
42	PRT10511-42	CARBON BRUSH (PAIR)
43	PRT10511-43	USE PRT10511-40-43
44	PRT10511-44	SCREW ST 4.2x18
45	PRT10511-45	SCREW ST 4.2x22
501	PRT10511-501	SPANNER
502	PRT10511-502	RUBBER PAD
503	PRT10511-503	WOOL BONNET
504	PRT10511-504	D SHAPE HANDLE
505	PRT10511-505	VELCRO PAD
01, 501, 502	PRT10511-PAD	RETROFIT KIT

# **WARNING**

**Some dust created by power sanding, sawing, grinding, drilling, and other construction activities contains chemicals known to cause cancer, birth defects or other reproductive harm. Some examples of these chemicals are:**

- **lead from lead-based paints,**
- **crystalline silica from bricks and cement and other masonry products, and**
- **arsenic and chromium from chemically-treated lumber.**

**Your risk from these exposures varies, depending on how often you do this type of work. To reduce your exposure to these chemicals: work in a well ventilated area, and work with approved safety equipment, such as those dust masks that are specially designed to filter out microscopic particles.**

## RPM's equivalents for indicator settings

Please note there is 5% - 10% tolerance on each setting.

Setting 1.: 1062 RPM

Setting 2.: 1842 RPM

Setting 3.: 1922 RPM

Setting 4.: 2331 RPM

Setting 5.: 2573 RPM

Setting 6.: 2988 RPM

