

DISTRIBUTED BY:
Pro Wood Finishes
14622 Southlawn Lane
Rockville MD 20850
Ph: (301) 424-3033

SALICE

and the 100% of the maximum heart rate (HR_{max}) were used as the target HR range. The HR_{max} was determined by the following equation: HR_{max} = 207 - 0.7 × age (years) (Åstrand & Rodahl 1986). The HR_{max} was determined by a 10-min test on a cycle ergometer at 100% of the maximum power output (PO_{max}) (Åstrand & Rodahl 1986). The HR_{max} was determined during the last 5 min of the test. The HR_{max} was determined by the following equation: HR_{max} = 207 - 0.7 × age (years) (Åstrand & Rodahl 1986).

The HR_{max} was determined by the following equation: HR_{max} = 207 - 0.7 × age (years) (Åstrand & Rodahl 1986).

The HR_{max} was determined by the following equation: HR_{max} = 207 - 0.7 × age (years) (Åstrand & Rodahl 1986).

The HR_{max} was determined by the following equation: HR_{max} = 207 - 0.7 × age (years) (Åstrand & Rodahl 1986).

The HR_{max} was determined by the following equation: HR_{max} = 207 - 0.7 × age (years) (Åstrand & Rodahl 1986).

The HR_{max} was determined by the following equation: HR_{max} = 207 - 0.7 × age (years) (Åstrand & Rodahl 1986).

The HR_{max} was determined by the following equation: HR_{max} = 207 - 0.7 × age (years) (Åstrand & Rodahl 1986).

The HR_{max} was determined by the following equation: HR_{max} = 207 - 0.7 × age (years) (Åstrand & Rodahl 1986).

The HR_{max} was determined by the following equation: HR_{max} = 207 - 0.7 × age (years) (Åstrand & Rodahl 1986).

The HR_{max} was determined by the following equation: HR_{max} = 207 - 0.7 × age (years) (Åstrand & Rodahl 1986).

The HR_{max} was determined by the following equation: HR_{max} = 207 - 0.7 × age (years) (Åstrand & Rodahl 1986).

The HR_{max} was determined by the following equation: HR_{max} = 207 - 0.7 × age (years) (Åstrand & Rodahl 1986).

The HR_{max} was determined by the following equation: HR_{max} = 207 - 0.7 × age (years) (Åstrand & Rodahl 1986).

The HR_{max} was determined by the following equation: HR_{max} = 207 - 0.7 × age (years) (Åstrand & Rodahl 1986).

The HR_{max} was determined by the following equation: HR_{max} = 207 - 0.7 × age (years) (Åstrand & Rodahl 1986).

The HR_{max} was determined by the following equation: HR_{max} = 207 - 0.7 × age (years) (Åstrand & Rodahl 1986).

The HR_{max} was determined by the following equation: HR_{max} = 207 - 0.7 × age (years) (Åstrand & Rodahl 1986).

The HR_{max} was determined by the following equation: HR_{max} = 207 - 0.7 × age (years) (Åstrand & Rodahl 1986).

The HR_{max} was determined by the following equation: HR_{max} = 207 - 0.7 × age (years) (Åstrand & Rodahl 1986).

The HR_{max} was determined by the following equation: HR_{max} = 207 - 0.7 × age (years) (Åstrand & Rodahl 1986).

The HR_{max} was determined by the following equation: HR_{max} = 207 - 0.7 × age (years) (Åstrand & Rodahl 1986).

The HR_{max} was determined by the following equation: HR_{max} = 207 - 0.7 × age (years) (Åstrand & Rodahl 1986).

The HR_{max} was determined by the following equation: HR_{max} = 207 - 0.7 × age (years) (Åstrand & Rodahl 1986).

The HR_{max} was determined by the following equation: HR_{max} = 207 - 0.7 × age (years) (Åstrand & Rodahl 1986).

Dear Customer,

many years of work and experience have strengthened our presence on the market at the customers' service. This encourages us to improve and progress to win your confidence.

We hope that this new catalogue will contribute to facilitating our co-operation and developing our relationship; the knowledge of your requirements is at the base of our constant research and innovation.

Arturo Salice S.p.A.



SALICE

The History



Salice workshop, end of the fifties
Packing of products to be shipped

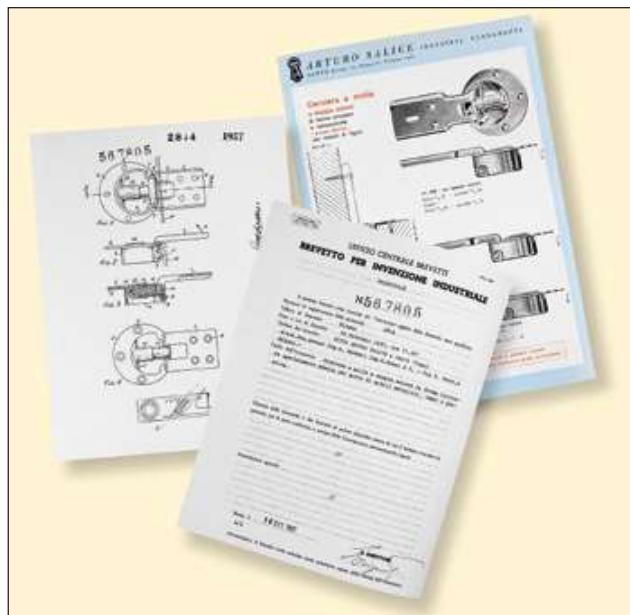

At the end of the fifties, the first factory is built in Cantù. Mr Arturo Salice starts the production of his own line of furniture hardware. His sons Giorgio and Luciano enter the company, supporting their father in the management and in upholding the typical values of the Lombard industrial tradition. On the 22nd February 1957 Salice registers the first patent covering a concealed, cylindrical and self-closing hinge for furniture; an authentic milestone of innovation and technology for the whole sector.

Thus Arturo Salice S.p.A. was born.



Salice, leader in the field of concealed hinges and accessories for furniture, produces a wide range of high quality products meant for industries specialized in the field of kitchen cabinets and furniture in general.

With 400 employees and 8 subsidiaries, Salice exports 65% of production to over 80 countries worldwide. Its history begins in 1926 when Arturo Salice starts in Cantù, Como province, a trade activity for the retail distribution of furniture hardware produced in Italy or imported from foreign countries. The activity, initially confined to the local area, soon extends to the whole of Italy.

Arturo Salice, end of the fifties



The rapid development of the company and the success that the Salice products achieve, both in Italy and abroad, require the construction of new production facilities.

In 1975, in Novedrate, on a 240.000 m² area the new factory is inaugurated, which is gradually enlarged and completed: today the built area covers 60.000 m².

Since the year 2000 the company ADAR S.p.A., now known as SALICE GUIDE S.p.A., specialized in the production of runners and metal drawers and since 2010 the company BORTOLUZZI SISTEMI S.p.A., specialized in the production of sliding door systems, complete the wide range of products.



Deutsche Salice, Neckarwestheim founded in 1971



The Subsidiaries

Salice is active in all the industrialized countries of the world through a network of exclusive distributors and agents. The sales and distribution functions are assisted by subsidiaries all over the world. In 1971 open the first two branches in Neckarwestheim, Germany and in Antibes, France. Meanwhile the company continues its evolution and in 1985 open the third branch in Huntingdon, England; between 1988 and 1989 Salice arrives in Mississauga, Canada and in Charlotte, United States. In 1993, in order to better support the German and American market, Salice decides to strengthen the services offered and open the branches in Löhne and in Los Angeles. Also in the Iberian peninsula Salice consolidates its presence in 2011 with the opening of Salice España in Barcelona.

Salice France founded in 1971



Salice UK founded in 1985



Salice Canada founded in 1988



Salice America, Charlotte founded in 1989



Deutsche Salice, Löhne founded in 1993



Salice America, Los Angeles founded in 1993



Salice España, founded in 2011



The Certifications

To the certification obtained by Salice in 1993 for its "QUALITY MANAGEMENT SYSTEM ISO 9001", in 1998 one for the "ENVIRONMENTAL MANAGEMENT SYSTEM ISO 14001" is added, to witness that the company is absolutely compliant with the laws that guarantee the safeguard of the environment. The certifications issued at the end of verifications, which Salice voluntarily underwent, guarantee its compliance to the rules set by the International Organization for Standardisation (ISO) and by the European Committee for Standardisation (CEN). The certification body chosen by Salice is DNV-Det Norske Veritas, a Norwegian control organisation founded in 1864 and internationally known for its professionalism and competence.



The Company



Salice Technological Centre in the Novedrate factory

The Research

A team of highly qualified technicians is constantly seeking new and always more sophisticated products which must meet the demands of the markets with high-precision and high-quality technical and technological solutions.



Technological Centre: Research and Development



Technological Centre: Technical Office

The Tooling Department

It operates inside the Technological Centre. In this department, the production equipment, tooling and assembly machines, resulting from the continual researches and computerized design of the Technical Office, are produced. This enables the company to promptly respond to the customers' requests and to offer the market always innovative and quality products.

The close link between this department and the production cycle enables Salice to produce in large quantities, with the highest possible degree of automation, keeping the total and constant control over the quality standards.



The Production

In 1957 Salice decides to concentrate all its energies on a single type of product: concealed hinges for furniture and relative accessories. This well-founded decision has allowed Salice to reach a high level of specialisation, supported by a policy of investments directed at innovation and rationalisation of production processes. The production cycle, on three shifts, is assured by workmanship of proven ability and competence. These characteristics have deservedly earned Salice the reputation of being the reliable and safe partner of the most prestigious furniture companies.

The Logistics

All production phases, assemblies, movements and deliveries are assisted by computerized systems which assure the correct course of every single operation, thus guaranteeing the fast execution of the orders, correct management of the shipments and punctual deliveries. A further cornerstone of service to the customers.



Customer Service

Salice primary goals are innovation, quality and customer service, to which Salice reserves the greatest attention. With the customer, Salice wishes to establish a close relationship of mutual collaboration. Every technical problem raised by the customer, existing or potential, is examined and evaluated by the experts of the Technical Office: a team of specialists who avail themselves of a C.A.D. system that integrates and assists the Research and Development department, analyses the problem and promptly solves it.

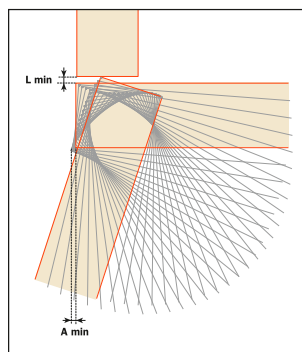

Abbreviations

page 11

Explanatory notes and assembly instructions

page 12

Sideways adjustment

page 14

Depth adjustment

page 15

Height adjustment

page 17



Silentia

Hinges with integrated

Soft-close

Series 100

page 20

Series 200 for thicker doors

page 28

For metal profiles

page 40

Series 700

page 46

Series 800

page 60

Series 900

page 66



Series 100

Hinges for doors with a minimum thickness of 10 mm

Technical features

page 72

105° opening

page 74

155° opening

page 76

Complementary hinges:

for wooden doors with positive angled assembly

page 78

crampon hinges

page 80



Series 200

Technical features

page 82

94° opening for thicker doors

page 84

110° opening

page 86

120° opening

page 88

155° opening

page 90

155° opening for thicker doors

page 92

165° opening

page 96

Complementary hinges:

for glass doors

page 98

for glass doors with positive angled assembly

page 100

crampon hinges for glass doors

page 100

for fridge doors

page 101

for wooden doors with positive angled assembly

page 102

for wooden doors with negative angled assembly

page 104

crampon hinges

page 105

for corner cabinets

page 108

Special angled assemblies

page 110



Series F

Hinges with cup diameter 40 mm, for thicker doors and doors with moulded profiles

Technical features

page 112

94° opening

page 114

Assembly examples

page 116



Series 300
Hinges with small operating profile

Technical features
94° opening

page 118
page 120



Series 800

Technical features
110° opening

page 124
page 126



Series 900

Technical features
110° opening

page 130
page 132



For metal profiles

Practical System
Accessories for the frame assembly
Assembly instructions
Series 200
Series 400

page 136
page 140
page 141
page 142
page 146



Mini hinges
Hinges with cup diameter 26 mm

Series 400
Technical features
94° opening
Complementary hinges:
for wooden doors with angled assembly
crampon hinges
Series 600
Technical features
94° opening
Complementary hinges:
for wooden doors with positive angled assembly
crampon hinges
for glass doors
for glass doors with positive angled assembly
crampon hinges for glass doors

page 150
page 152
page 154
page 154
page 156
page 158
page 160
page 161
page 162
page 163
page 163



Serie B
Hinges that need to be bonded to glass

For glass doors
Technical features
110° opening

page 166
page 167



Serie B
Hinges for half-inset doors or doors with moulded profiles

For wooden doors
Technical features
110° opening
Assembly examples

page 168
page 170
page 172



Push
Push to open system for handle-less doors

Mechanical Push
Retaining catches for wooden doors
Retaining catches for aluminium-frame doors
Adapters
Spacers and insertion tool for retaining catch
Assembly instructions and drillings

page 182
page 186
page 187
page 188
page 189
page 190

Magnetic Push
Release devices and retaining catches
Adapters
Assembly instructions
Magnetic retaining

page 196
page 197
page 198
page 201

Push hinges
Series 200 hinges
Hinges for metal profiles
Series B hinges

page 204
page 220
page 228



Domi snap-on mounting plates

page 236



Series 200 mounting plates with traditional assembly

page 240



Series 300 mounting plates

page 248



Smove

Soft-Close systems for doors

Adjustable

D0S_SNG
DOL_SNG
DOL_SNGR
DB01SN_

page 250
page 255
page 255
page 257

To be recessed

D005SN
D006SN
D008SN
D009SN
D010SN

page 258
page 259
page 260
page 261
page 262

Adapters

page 264



Sliding system for concertina doors

Technical features
Elements of the system
Adjustments
Assembly instructions
Packaging and code number

page 272
page 273
page 274
page 276
page 279



Lift - Opening systems

Flap door page 282
Folding door page 302
Parallel opening door for doors from 360 mm to 440 mm height page 314
Parallel opening door for doors from 440 mm to 660 mm height page 318
Swing opening door page 334



Connecting fitting

page 346



Accessories

Screw cover caps	page 350
Flange cover caps	page 351
Spacers, gange and fancy cover for Silentia hinges	page 351
Fancy covers for glassdoor hinge cup	page 352
Spacers for Series 200, F and 600 hinges	page 353
Stop devices	page 354

Abbreviations

Application with full overlay door

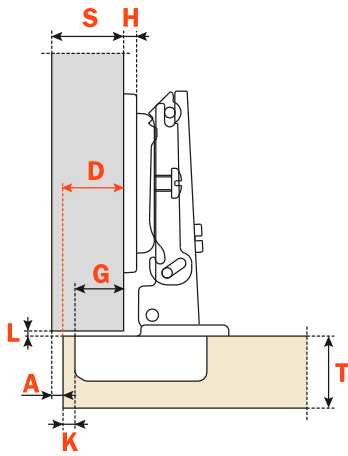

- S** = Thickness of the cabinet side
- D** = Required door overlay
- T** = Door thickness
- K** = Drilling distance
- A** = Reveal
- L** = Gap between door and carcass
- H** = Height of the mounting plate
- G** = Hinge constant

Whatever door overlay is required, you can select from our range the combination of both the type of hinge arm and the thickness of mounting plate necessary to solve your construction problem and avoid the need to stock too many different components.

Application with half overlay door

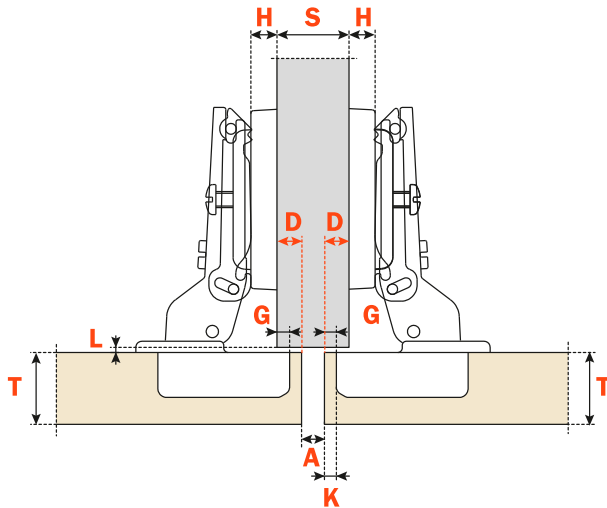

Application with inset door

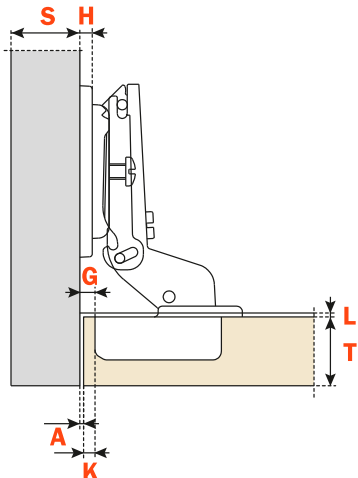

- S** = Thickness of the cabinet side
- T** = Door thickness
- K** = Drilling distance
- A** = Reveal
- L** = Gap between internal face of door and internal cabinet elements (e.g. shelves, drawers, etc.)
- H** = Height of the mounting plate
- G** = Hinge constant

Whatever door overlay is required, you can select from our range the combination of both the type of hinge arm and the thickness of mounting plate necessary to solve your construction problem and avoid the need to stock too many different components.

Explanatory notes and assembly instructions

Simulation of the opening movement of a 110° hinge with full overlay door

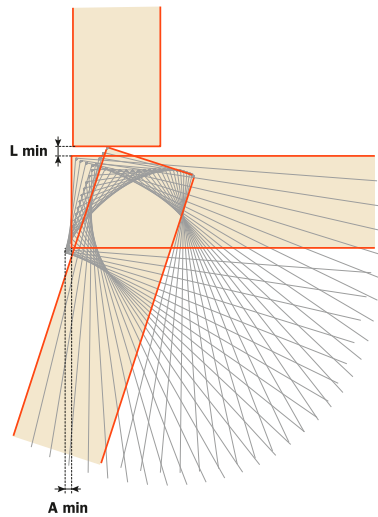

Simulation of the opening movement of a 110° hinge with half overlay door

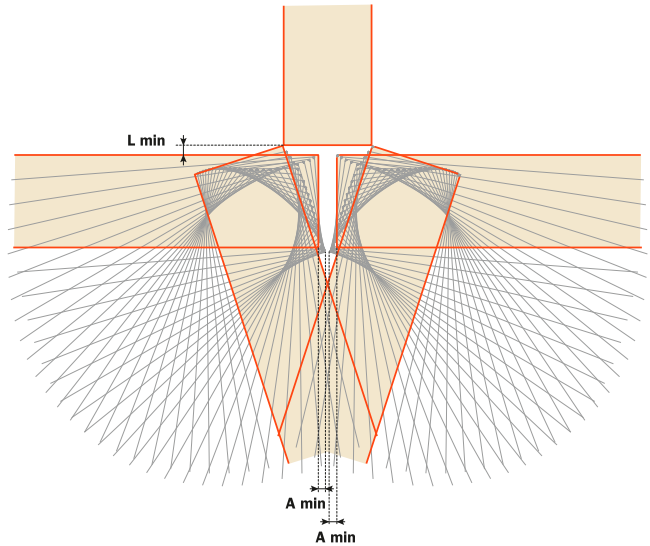

For hinges Series 100, 200, F, 400, B, M and Silentia

Traditional assembly with Series 200 mounting plates

Assembly with Domi snap-on mounting plates

Place the hinge onto the mounting plate. Push the hinge up to the pre-determined stop under the hinge arm.

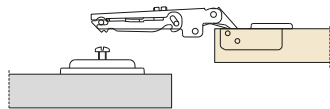

Locate the lugs on the mounting plate into the recesses beneath the arm.

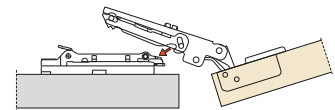

Tighten the fixing screw.

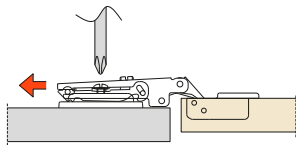

Gently rotate the door in the direction shown.

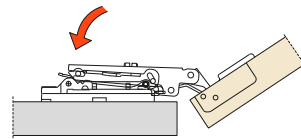

An "L" value of 0.7 mm between door and cabinet side is achieved on final assembly.

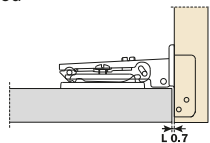

Then press lightly on the end of the arm to secure the catch.

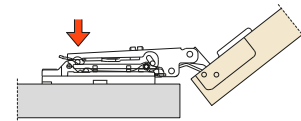

"Key hole" safety feature.

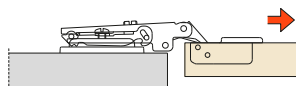

To remove the hinge from the mounting plate, press gently in the places shown by the arrows.

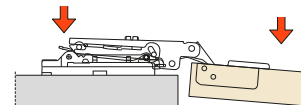

For hinges Series 300

Traditional assembly with Series 300 mounting plates

Place the hinge onto the mounting plate. Push the hinge up to the pre-determined stop under the hinge arm.

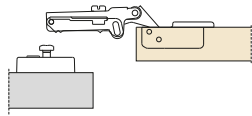

Tighten the fixing screw.

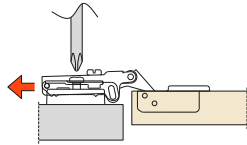

An "L" value of 0.7 mm between door and cabinet side is achieved on final assembly.

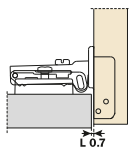

"Key hole" safety feature.

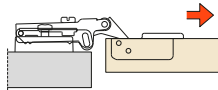

For hinges Series 800

Assembly with Series 200 steel mounting plates

Locate the lugs on the mounting plate into the recesses beneath the arm.

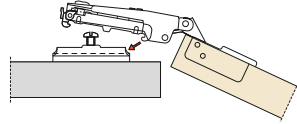

Gently rotate the door in the direction shown. Then press lightly on the end of the arm to secure the catch.

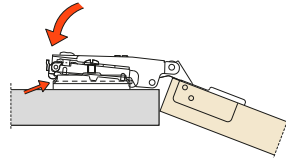

An "L" value of 0.7 mm between door and cabinet side is achieved on final assembly.

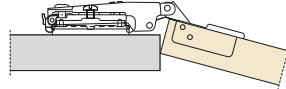

To remove the hinge from the mounting plate, press gently in the place shown by the arrows.

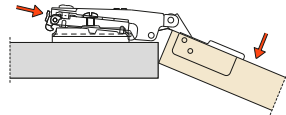

For hinges Series 600 and 900

Traditional assembly with Series 200 mounting plates

Place the hinge onto the mounting plate. Push the hinge up to the pre-determined stop under the hinge arm.

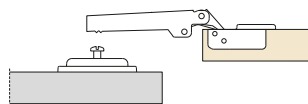

Tighten the fixing screw.

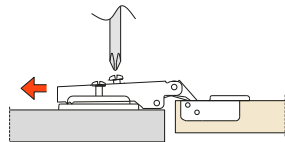

An "L" value of 0.7 mm between door and cabinet side is achieved on final assembly.

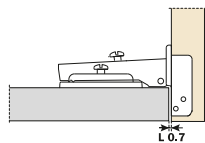

"Key hole" safety feature.

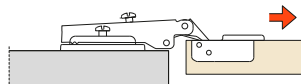

Sideways adjustment

Sideways adjustment of the door with Series 100, 200, 300, F, 400, B, M and Silentia hinges

A specially developed technical solution allows the sideways adjustment of the door while maintaining the gap behind the door ("L" value of 0.7 mm). The adjustment screw operates in conjunction with the inner leaf of the hinge arm. The door moves in only one direction - parallel to the carcass and without a gap developing between the door and the carcass. No further adjustments are necessary.

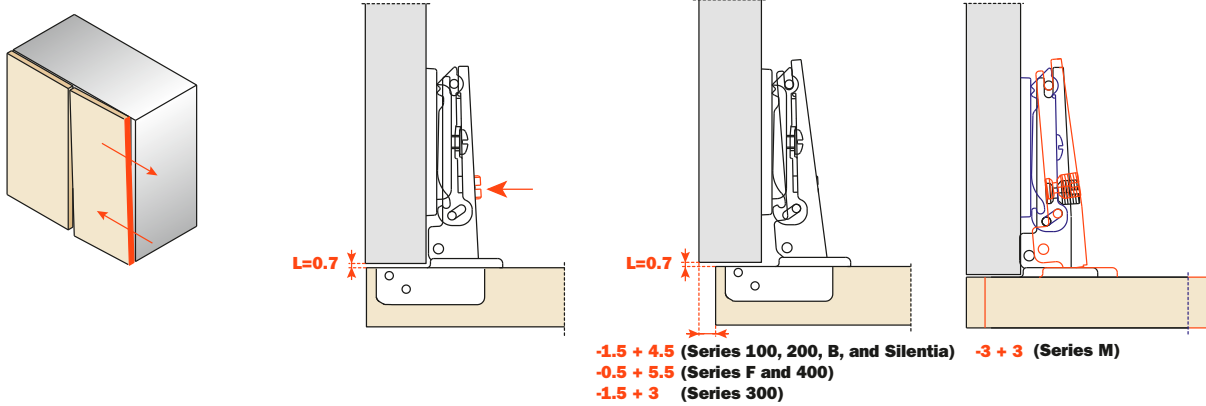

Sideways adjustment of the door with Series 800 hinges and Silentia Series 800 hinges

Sideways adjustment of the door is made by using the indicated screw. It is possible to recover the gap behind the door (the initial "L" value of 0.7 mm) simply by using the assembly stop located on the underside of the hinge.

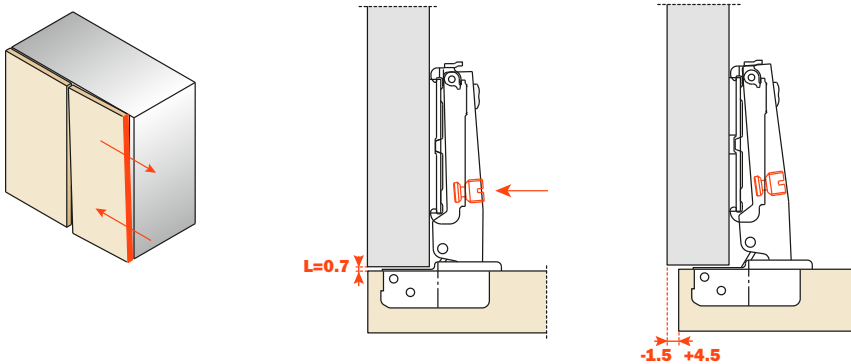

Sideways adjustment of the door with Series 900 and 600 hinges and Silentia Series 900 hinges

Required sideways adjustment of the door is made by slackening the hinge fixing screw. It is possible to recover the gap behind the door (the initial "L" value 0.7 mm) simply by using the assembly stop located on the underside of the hinge. Finally the fixing screw must be retightened.

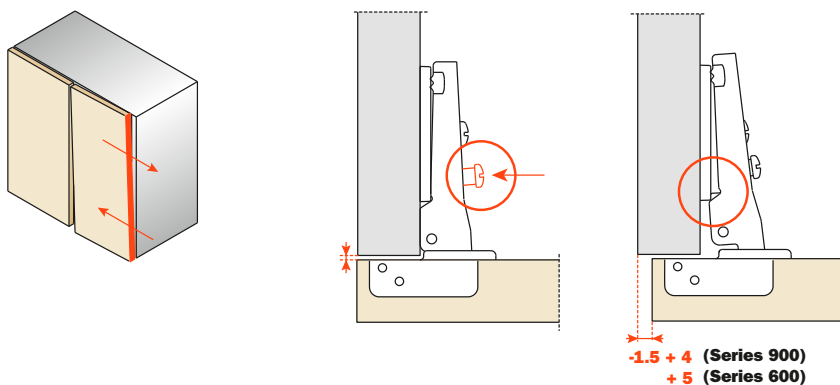

Depth adjustment

Traditional depth adjustment

The hinge fixing screw is slackened and an oval slot on the arm of the hinge enables the door to be adjusted frontally by + 2.8 mm. Finally the fixing screw must be retightened.

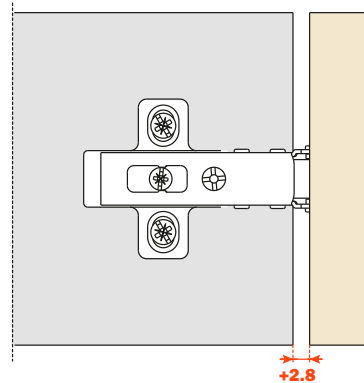
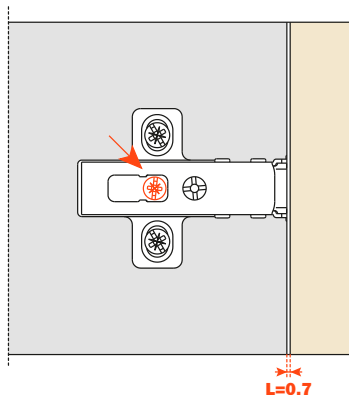
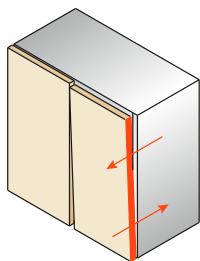

Traditional depth adjustment with Series 800 hinges

The hinge fixing screw is slackened and an oval slot on the arm of the hinge enables the door to be adjusted frontally from -1.5 mm to +3 mm. Finally the fixing screw must be retightened.

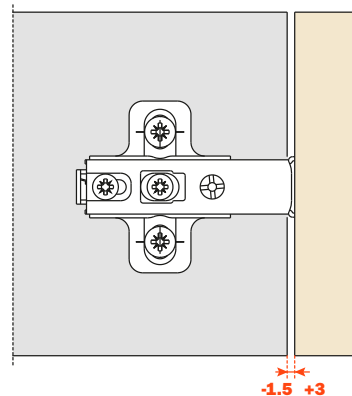
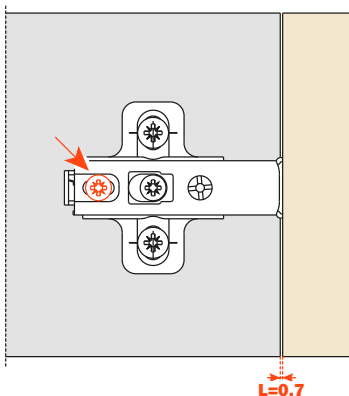
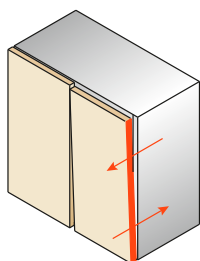

Depth adjustment with Domi snap-on mounting plates - Model BAV

Depth adjustment is made without loosening any screws. The door can be moved frontally from -0.5 mm to +2.8 mm simply by rotating the cam adjuster in this range of mounting plates.

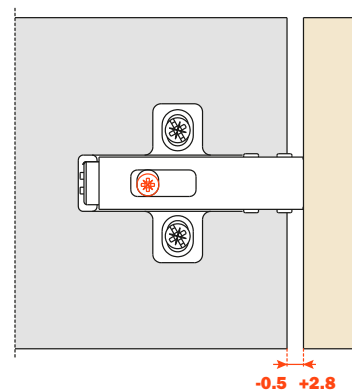
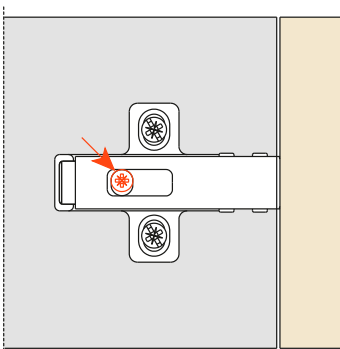
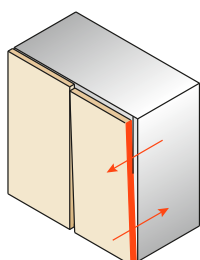

Depth adjustment

Depth adjustment with Domi snap-on mounting plates - Models BAPXR and BARXR

Depth adjustment is made without loosening any screws. The door can be moved frontally from -0.5 mm to +2.8 mm simply by rotating the cam adjuster in this range of mounting plates.

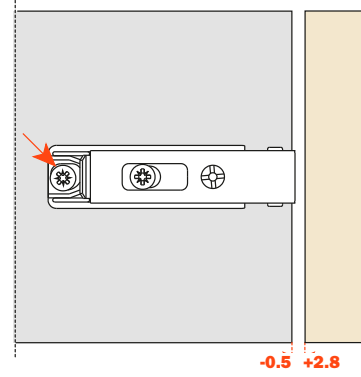
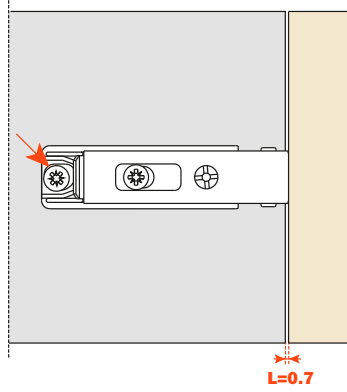
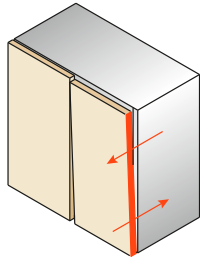

Height adjustment

Height adjustment with Domi snap-on mounting plates - Model BAV - Series 200

By loosening the two fixing screws it is possible to adjust the door vertically by ± 2 mm. The oval holes allow the mounting plate to slide freely in both directions. Finally, the screws must be retightened.

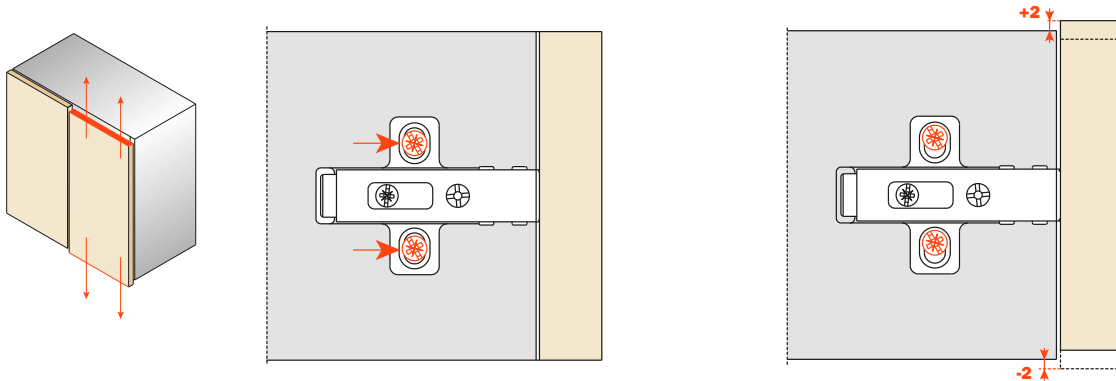

Height adjustment with Series 200 mounting plates - Models B2RXE and B2PXE

Height adjustment is made without loosening any screws. The door can be moved vertically by ± 2 mm simply by rotating the cam adjuster in this range of mounting plates.

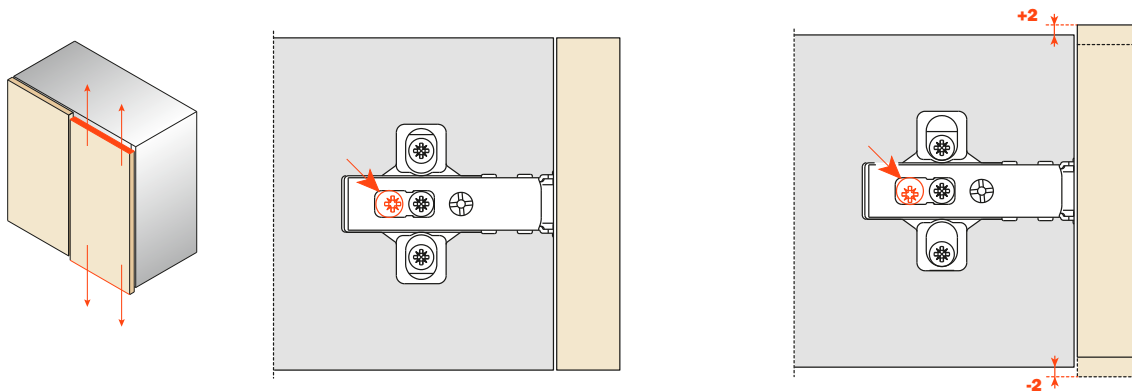

Height adjustment with Domi snap-on mounting plates - Models BAPXR and BARXR

Height adjustment is made without loosening any screws. The door can be moved vertically by ± 2 mm simply by rotating the cam adjuster in this range of mounting plates.

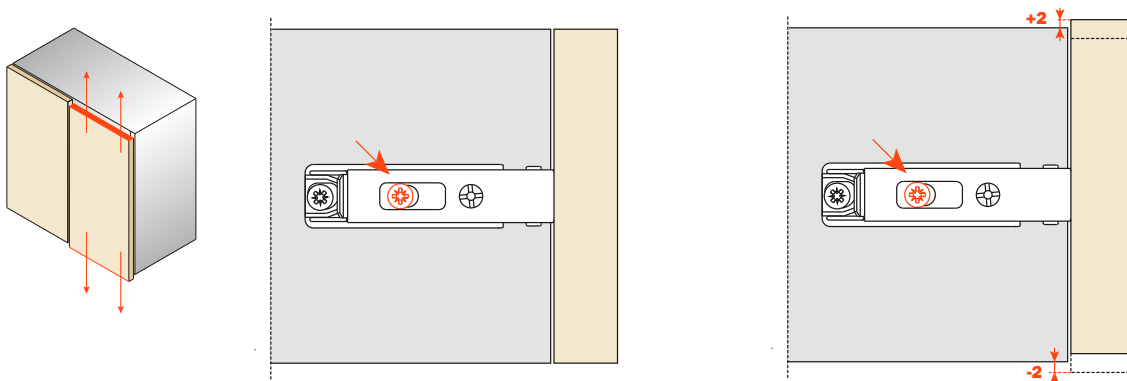

Silentia - Series 100



Hinges with integrated soft-close mechanism in the hinge cup.

Bright nickel plated steel cup and arm.
Dimensions of the Ø 35 mm cup.
Hinges for doors of small weight and thickness.

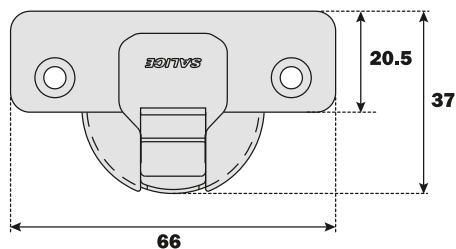

Constant "L" value of 0.7 mm (it does not change during side adjustment).

Approx. number of hinges required according to the door dimension and weight.

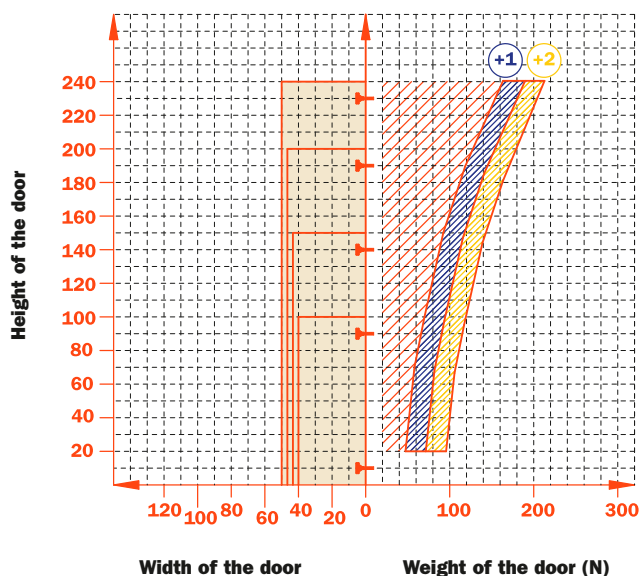

Adjustments

Compensated side adjustment from -1.5 mm to +4.5 mm.
 Height adjustment ± 2 mm.
 Depth adjustment with Series 200 mounting plates +2.8 mm.
 Depth adjustment with Domi snap-on mounting plates from -0.5 mm to +2.8 mm.
 Anti-sliding safety stop.

Mounting plates

Symmetrical and asymmetrical bright nickel plated steel or die-cast Series 200 mounting plates.
 Snap-on assembly on Domi mounting plates.
 Positioning with pre-determined stop on traditional Series 200 mounting plates.

N.B. : Use POZIDRIVE No. 2 screwdrivers for all screws.

		<p>48 $\varnothing 35$ 6 105°</p>	<p>45 $\varnothing 35$ 9.5 105°</p>	<p>52 $\varnothing 35$ 5.5 105°</p>
Wood screw		A	P	U
		<p>48 $\varnothing 35$ $\varnothing 10$ 6 105°</p>	<p>45 $\varnothing 35$ $\varnothing 8$ 9.5 105°</p>	<p>52 $\varnothing 35$ $\varnothing 10$ 5.5 105°</p>
Rapido		6	7	2
Dowel		B	R	W
Logica		I	J	Q

Use this table to identify the available drillings and fixings.
 Fill the third position of the hinge code number with the letter or the number corresponding to your choice. I.e.: C1_6AD9.

↑
 Fill this position with the chosen letter or number.

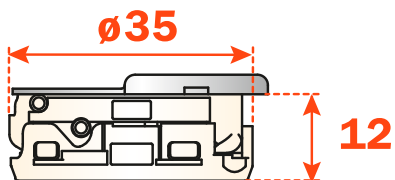

**105° opening
 and complementary hinges**



Attention:
 it is essential to drill the door as specified for
 the perfect functioning of the hinge.



Technical information

Hinges with integrated soft-close mechanism in the hinge cup.

**Hinges for doors of small weight and thickness.
12 mm deep cup.**

105° opening.
Possible drilling distance on the door (K): from 3 to 6 mm.
Compatible with all traditional Series 200 mounting plates and with all Domi snap-on mounting plates.

Space needed to open the door

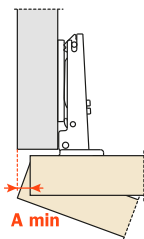

	T=	15	16	17	18	19	20
K=3	A=	1.0	1.0	1.2	1.4	1.6	1.9
K=4	A=	0.9	1.0	1.2	1.3	1.5	1.8
K=5	A=	0.9	1.0	1.1	1.2	1.5	1.8
K=6	A=	0.9	1.0	1.1	1.2	1.4	1.7

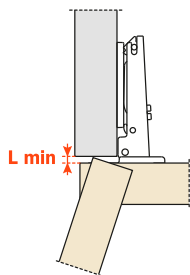

	T=	15	16	17	18	19	20
K=3	L=	0.0	0.0	0.0	0.0	0.1	0.3
K=4	L=	0.4	0.6	0.7	0.9	1.1	1.2
K=5	L=	1.0	1.0	1.2	1.8	2.0	2.0
K=6	L=	1.6	1.8	2.0	2.1	2.3	2.5

The above values are calculated on the assumption that the doors have square edges. They are reduced if the doors have radiussed edges.

Projection of the door

Projection of the door from the cabinet side at the max. opening. The figures are based on a straight arm hinge, H=0 mm thickness of mounting plate and K value = 3 mm.

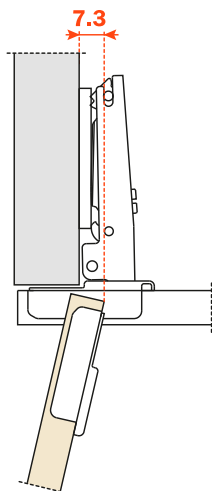

“C” value

With this formula you can obtain the max. thickness of the moulded door that can be opened without touching adjacent carcass sides, doors or walls, whilst bearing in mind the above L-K-T values.

$$C = 20.5 + K + A$$

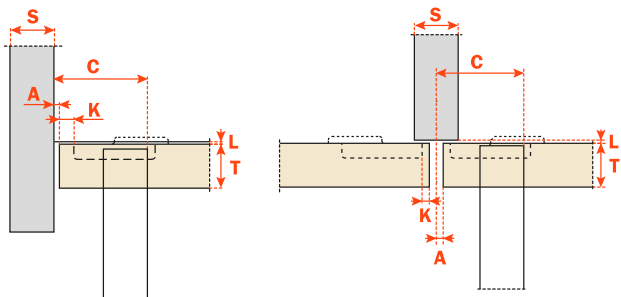

Packing

Boxes 300 pcs.
Pallets 7.200 pcs.

Use these formulas to determine the type of hinge arm, the drilling distance "K" and the height of the mounting plate "H" which is necessary to solve each application problem.

Use the tables "Drillings and fixings" at page 21 to complete the code number of the desired hinge.

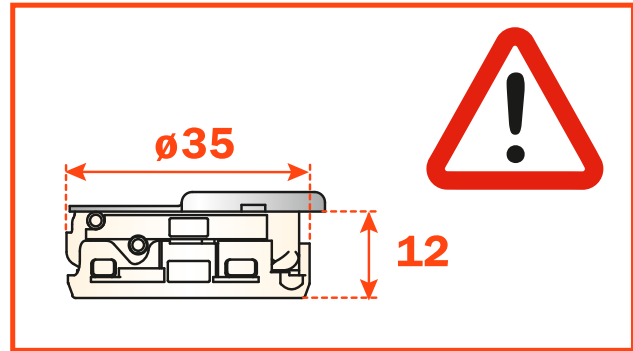
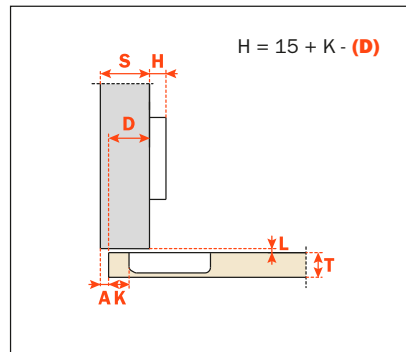
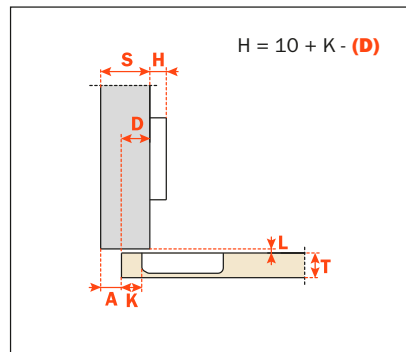
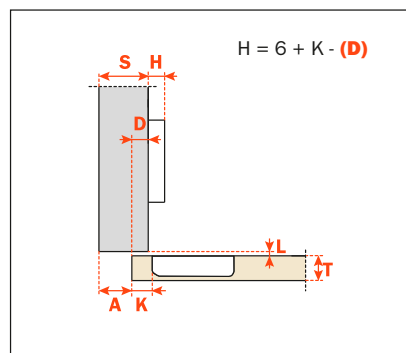
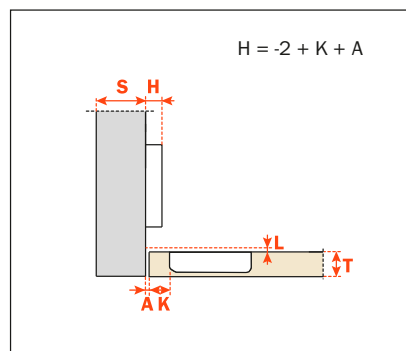
**Arm 0****C1_6AD9****Arm 5****C1_6DD9****Arm 9****C1_6GD9****Arm 17****C1_6PD9**



Technical Information

Hinges with integrated soft-close mechanism in the hinge cup.

**For wooden doors with positive angled assembly.
Hinges for doors of small weight and thickness.
12 mm deep cup.**

105° opening.
Possible drilling distance on the door (K): from 3 to 6 mm.
Compatible with all traditional Series 200 mounting plates and with all Domi snap-on mounting plates.

Packing

Boxes 150 pcs.
Pallets 3.600 pcs.

The solution of assembly problems where doors are mounted at a positive angle requires the verification of drilling distances by a practical trial. Please do not hesitate to consult our technical support department for assistance.

Use the tables “Drillings and fixings” at page 21 to complete the code number of the desired hinge.

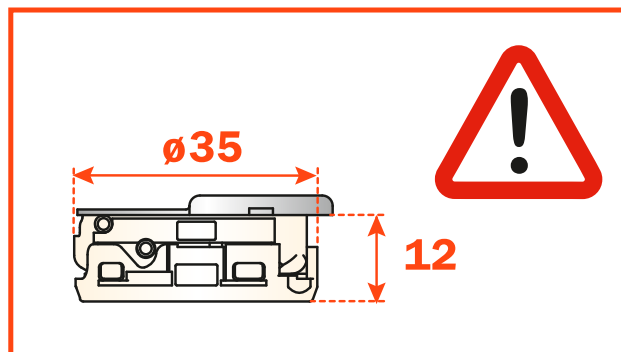

Arm 15°

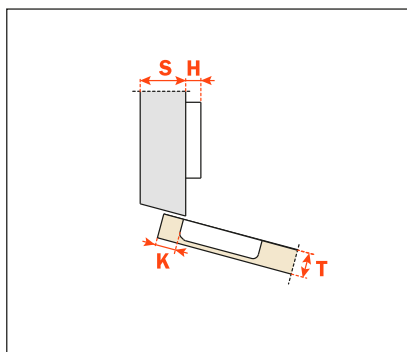

C1_6ZD9

Arm 24°

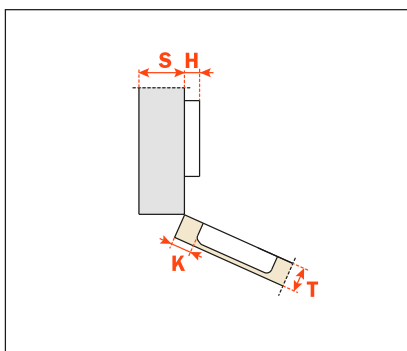

C1_6UD9

Arm 30°

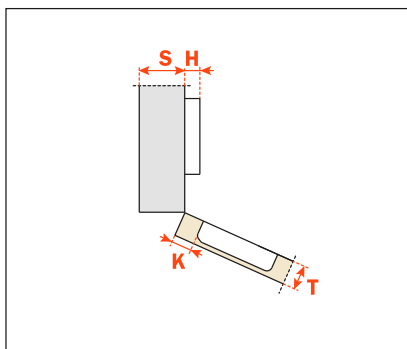

C1_6ED9

Arm 30°

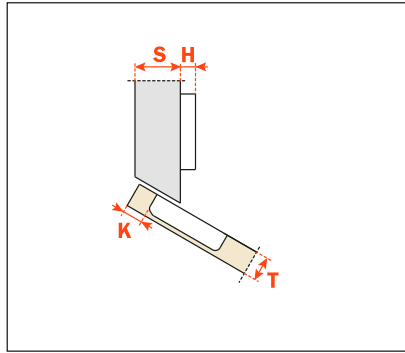

C1_6TD9

Arm 37°

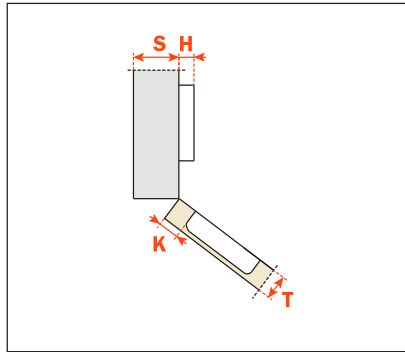

C1_6KD9

Arm 45°

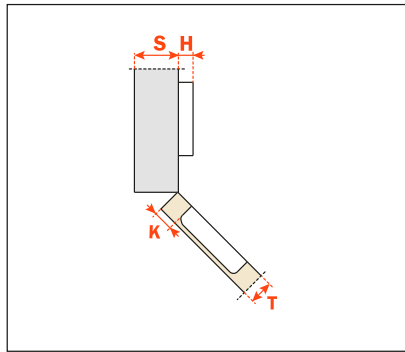

C1_6MD9

Arm 45°

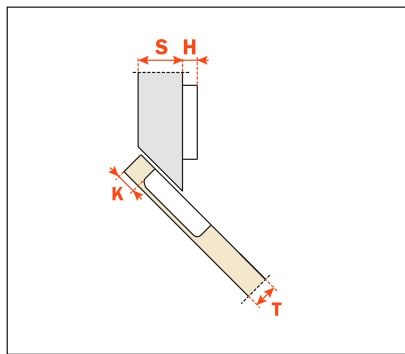

C1_6VD9

Arm 45°

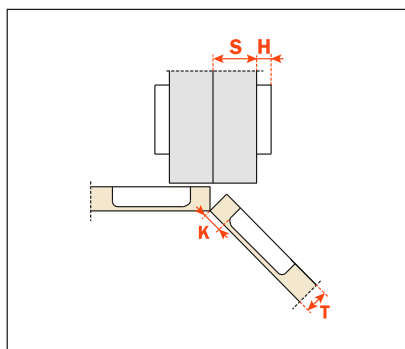

C1_6MD9AC



Technical Information

Hinges with integrated soft-close mechanism in the hinge cup.

Crampon hinges.

For cabinet sides with 37x32 standard drilling.

Hinges for doors of small weight and thickness.

12 mm deep cup.

105° opening.

Possible drilling distance on the door (K): from 3 to 6 mm.

Compatible with all traditional Series 200 mounting plates and with all Domi snap-on mounting plates.

Packing

Boxes 150 pcs.

Pallets 3.600 pcs.

E min:

61 mm for Series 200 mounting plates.

70 mm for Domi snap-on mounting plates.

74 mm for Domi snap-on mounting plates with back cam.

Use the tables "Drillings and fixings" at page 21 to complete the code number of the desired hinge.

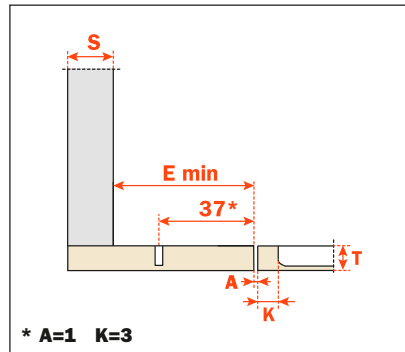
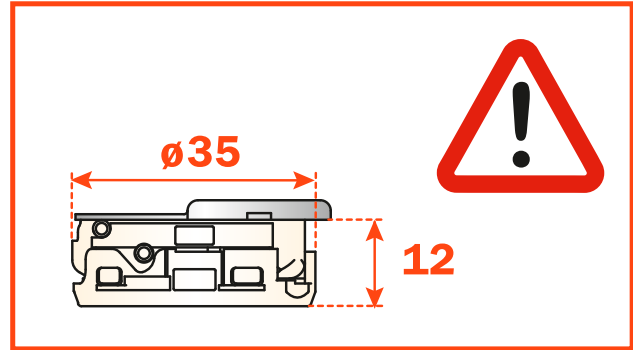

C1_6ND9AC

Heights of mounting plates for every assembly.

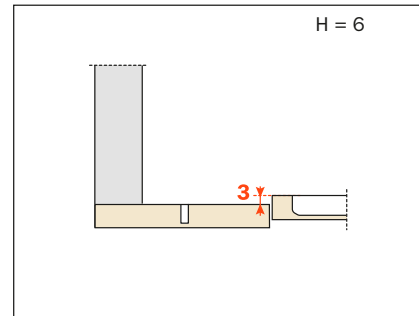
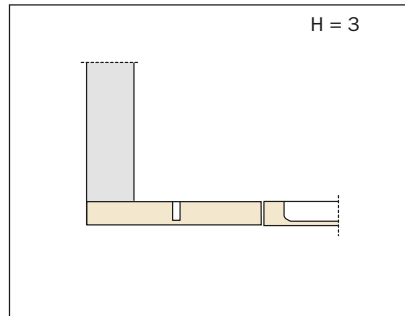
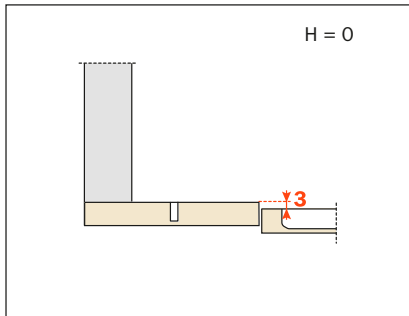

Silentia - Series 200 for thicker doors



Silentia - Series 200
for thicker doors

Hinges with integrated soft-close mechanism in the hinge cup.

Bright nickel plated steel cup and arm.
Dimensions of the Ø 35 mm cup.

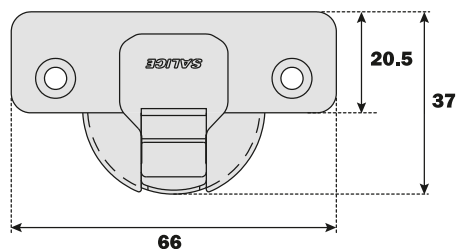

Constant "L" value of 0.7 mm (it does not change during side adjustment).

Approx. number of hinges required according to the door dimension and weight.

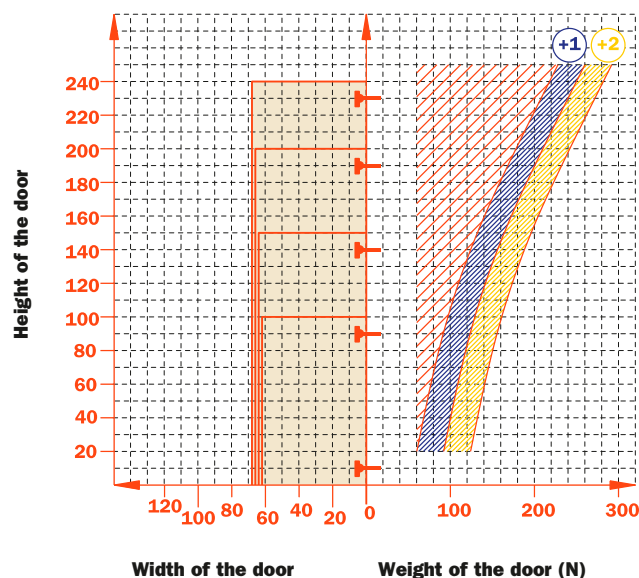

Adjustments

Compensating side adjustment from -1.5 mm to +4.5 mm.
 Height adjustment ± 2 mm.
 Depth adjustment with Series 200 mounting plates +2.8 mm.
 Depth adjustment with Domi snap-on mounting plates from -0.5 mm to +2.8 mm.
 Anti-sliding safety stop.

Mounting plates

Symmetrical and asymmetrical bright nickel plated steel or die-cast Series 200 mounting plates.
 Snap-on assembly on Domi mounting plates.
 Positioning with pre-determined stop on traditional Series 200 mounting plates.

N.B. : Use POZIDRIVE No. 2 screwdrivers for all screws.

Wood screw		A	A	P	P	U	U
Rapido		6	6	7	7	2	2
Dowel		B	B	R	R	W	W
Logica		I	I	J	J	Q	Q

Use this table to identify the available drillings and fixings.

Fill the third position of the hinge code number with the letter or the number corresponding to your choice. I.e.: C2_BAD9.

↑
Fill this position with the chosen letter or number.

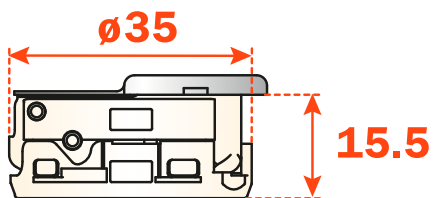

**94°, 155° opening
and complementary hinges**



Attention:
it is essential to drill the door as specified for the perfect functioning of the hinge.



Technical information

Hinges with integrated soft-close mechanism in the hinge cup.

**Hinges for min. 18 mm thick doors.
15.5 mm deep cup.**

94° opening.
Possible drilling distance on the door (K): from 3 to 9 mm.
Compatible with all traditional Series 200 mounting plates and with all Domi snap-on mounting plates.

Space needed to open the door

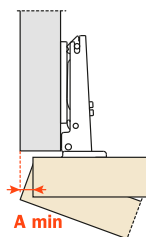

T=	19	20	21	22	23	24	25	26	27	28	29	30	31	32	33	34	35
K=3 A=	0.1	0.2	0.3	0.4	0.5	0.7	0.8	1.0	1.6	2.6	3.5	4.5	5.4	6.4	7.4	8.3	9.3
K=4 A=	0.1	0.2	0.3	0.4	0.5	0.7	0.8	1.0	1.2	1.9	2.8	3.8	4.7	5.7	6.6	7.6	8.6
K=5 A=	0.1	0.2	0.3	0.4	0.5	0.7	0.8	1.0	1.2	1.4	2.2	3.1	4.1	5.0	5.9	6.9	7.8
K=6 A=	0.1	0.2	0.3	0.4	0.5	0.6	0.8	1.0	1.2	1.4	1.7	2.6	3.5	4.4	5.3	6.2	7.2
K=7 A=	0.1	0.2	0.3	0.4	0.5	0.6	0.8	1.0	1.1	1.3	1.6	2.1	3.0	3.8	4.7	5.6	6.5
K=8 A=	0.1	0.2	0.3	0.4	0.5	0.6	0.8	0.9	1.1	1.3	1.6	1.8	2.5	3.3	4.2	5.1	6.0
k=9 A=	0.1	0.2	0.3	0.4	0.5	0.6	0.8	0.9	1.1	1.3	1.5	1.8	2.1	2.9	3.7	4.6	5.4

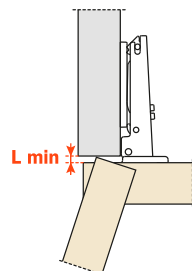

K	3	4	5	6	7	8	9
L=	0.0	0.0	0.0	0.0	0.0	0.3	1.3

The above values are calculated on the assumption that the doors have square edges. They are reduced if the doors have radiused edges.

Projection of the door

Projection of the door from the cabinet side at the max. opening. The figures are based on a straight arm hinge, H=0 mm thickness of mounting plate and K value = 3 mm.

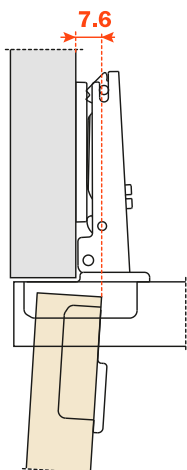

“C” value

With this formula you can obtain the max. thickness of the moulded door that can be opened without touching adjacent carcass sides, doors or walls, whilst bearing in mind the above L-K-T values.

$$C = 23 + K + A$$

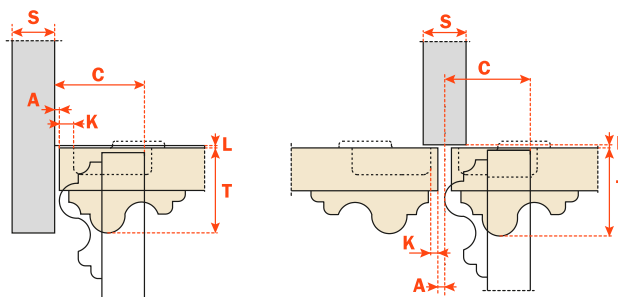

Packing

Boxes 300 pcs.
Pallets 7.200 pcs.

Use these formulas to determine the type of hinge arm, the drilling distance "K" and the height of the mounting plate "H" which is necessary to solve each application problem.

Use the tables "Drillings and fixings" at page 29 to complete the code number of the desired hinge.

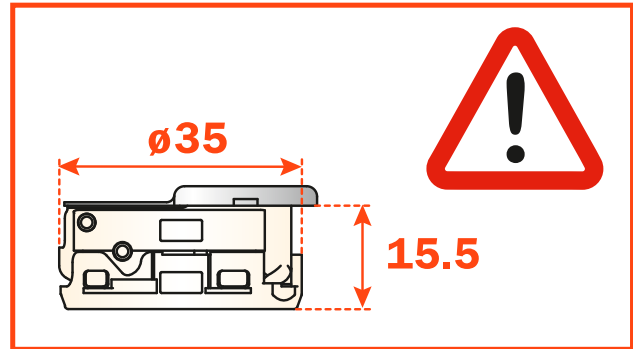
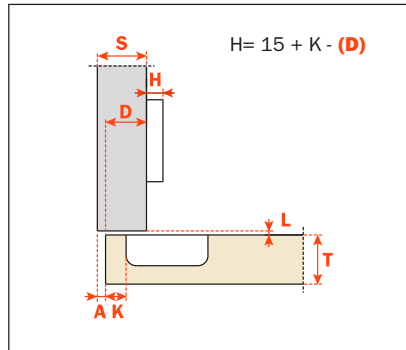
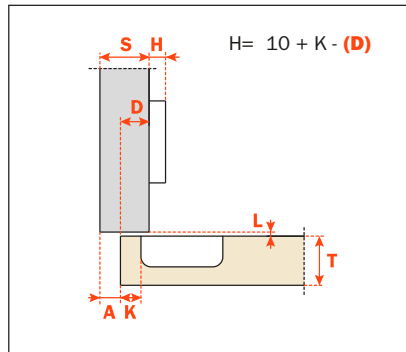
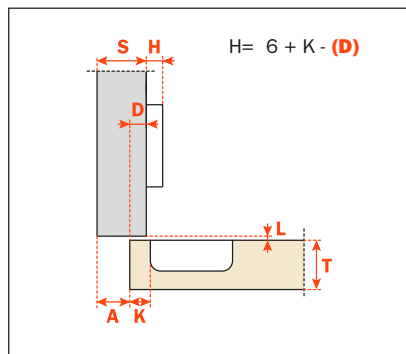
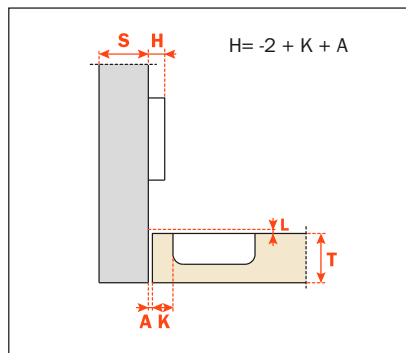
**Arm 0****C2_BAD9****Arm 5****C2_BDD9****Arm 9****C2_BGD9****Arm 17****C2_BPD9**



Technical information

Hinges with integrated soft-close mechanism in the hinge cup.

**Hinges for min. 18 mm thick doors.
15.5 mm deep cup.**

155° opening.

Possible drilling distance on the door (K): from 3 to 9 mm.

Compatible with all traditional Series 200 mounting plates and with all Domi snap-on mounting plates.

Space needed to open the door

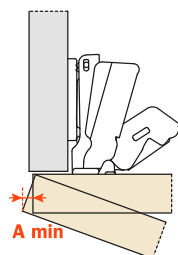

T=	26	27	28	29	30	31	32	33	34	35
K=3	A= 0.0	0.0	0.0	0.8	3.0	4.8	7.1	11.7	16.4	20.7
K=4	A= 0.0	0.0	0.0	0.8	2.5	4.0	6.2	10.6	15.0	19.7
K=5	A= 0.0	0.0	0.0	0.8	2.0	3.4	4.8	9.8	14.1	18.4
K=6	A= 0.0	0.0	0.0	0.8	1.5	2.8	4.2	8.7	13.2	17.8
K=7	A= 0.0	0.0	0.0	0.8	1.4	2.3	3.0	7.8	12.0	16.7
K=8	A= 0.0	0.0	0.0	0.2	0.9	1.9	2.7	7.0	11.2	15.7
K=9	A= 0.0	0.0	0.0	0.2	0.7	1.5	2.1	5.9	10.4	15.0

The above values are calculated on the assumption that the doors have square edges. They are reduced if the doors have radiussed edges.

“C” value

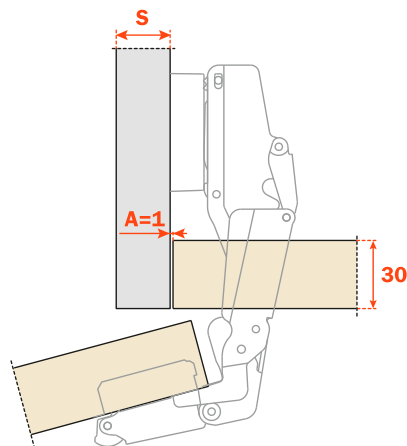
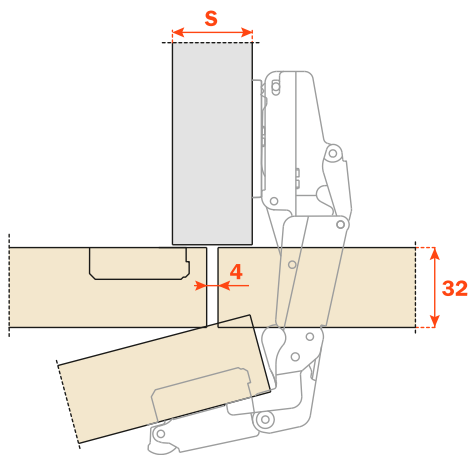

Packing

Boxes 100 pcs.
Pallets 2.400 pcs.

Use these formulas to determine the type of hinge arm, the drilling distance "K" and the height of the mounting plate "H" which is necessary to solve each application problem.

To limit the opening of the hinge, see page 354 chapter "Accessories".

Use the tables "Drillings and fixings" at page 29 to complete the code number of the desired hinge.

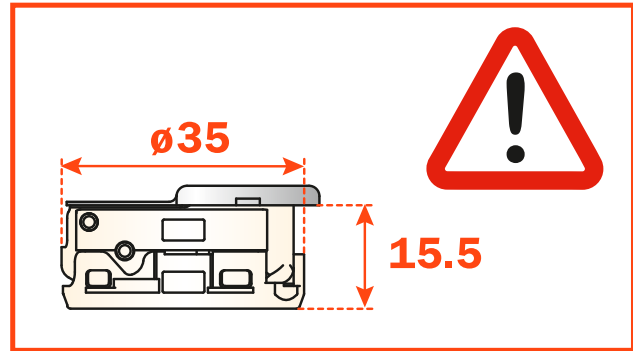

Arm 0

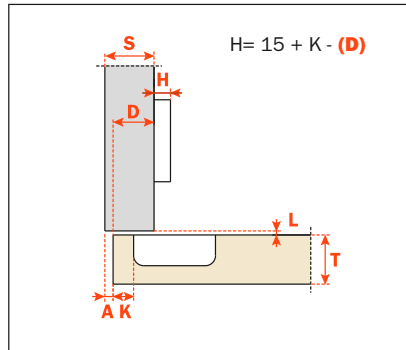
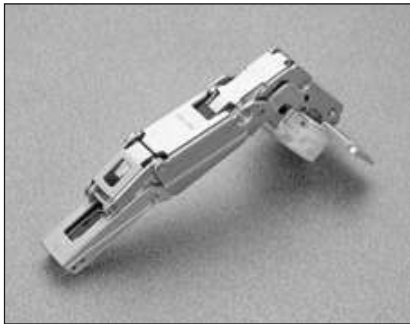
**C2_DAD9**

Arm 5

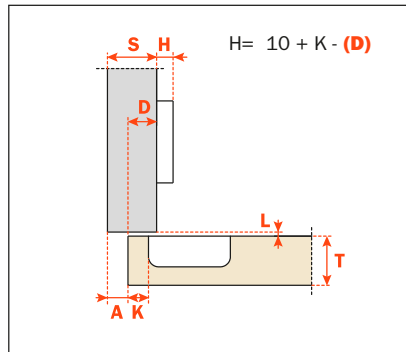
**C2_DDD9**

Arm 9

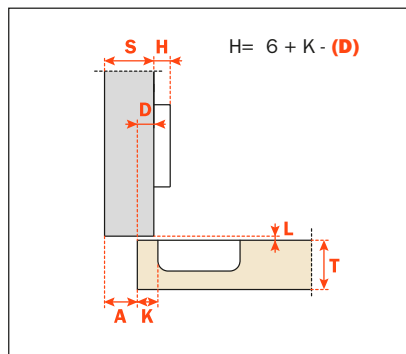
**C2_DGD9**



Technical information

Hinges with integrated soft-close mechanism in the hinge cup.

**For wooden doors with positive angled assembly.
Hinges for min. 18 mm thick doors.**

15.5 mm deep cup.

94° opening.

Possible drilling distance on the door (K): from 3 to 9 mm.

Compatible with all traditional Series 200 mounting plates and with all Domi snap-on mounting plates.

Packing

Boxes 150 pcs.

Pallets 3.600 pcs.

The solution of assembly problems where doors are mounted at a positive angle requires the verification of drilling distances by a practical trial. Please do not hesitate to consult our technical support department for assistance.

Use the tables "Drillings and fixings" at page 29 to complete the code number of the desired hinge.

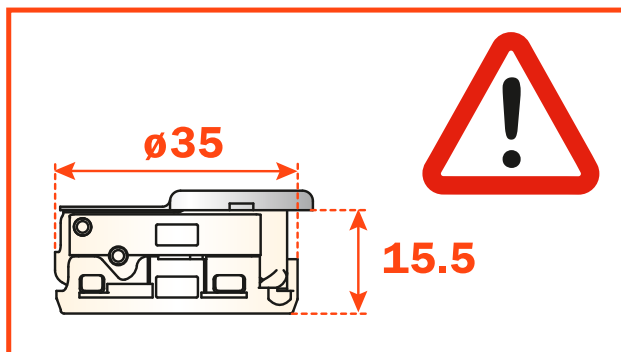

Arm 15°

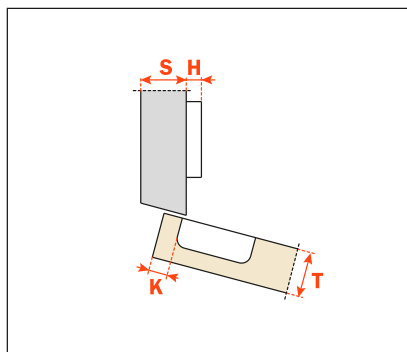

C2_BZD9

Arm 24°

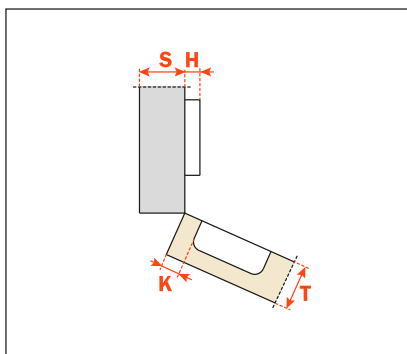

C2_BUD9

Arm 30°

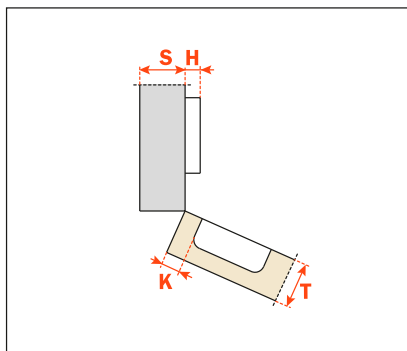

C2_BED9

Arm 30°

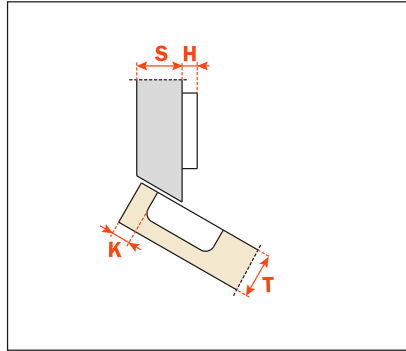

C2_BTD9

Arm 37°

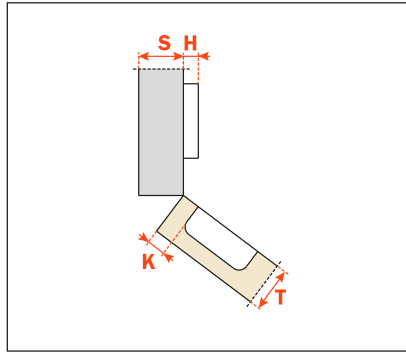

C2_BKD9

Arm 45°

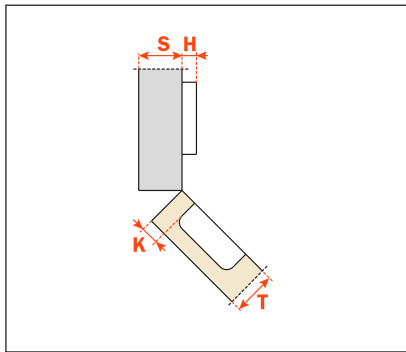

C2_BMD9

Arm 45°

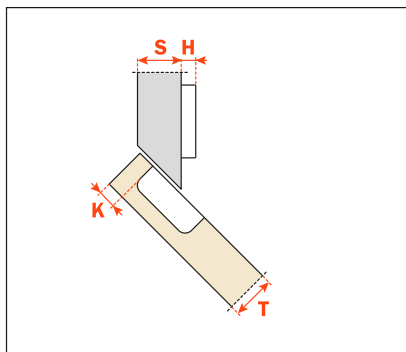

C2_BVD9

Arm 45°

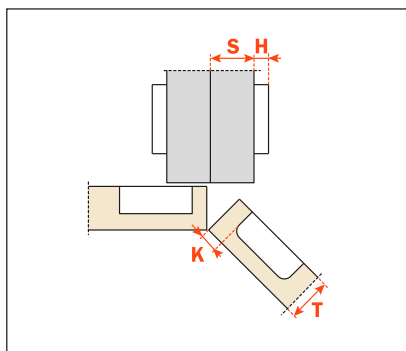

C2_BMD9AC



Technical information

Hinges with integrated soft-close mechanism in the hinge cup.

Crampon hinges.

For cabinet sides with 37x32 mm standard drilling.

Hinges for min. 18 mm thick doors.

15.5 mm deep cup.

94° opening.

Possible drilling distance on the door (K): from 3 to 9 m.

Compatible with all traditional Series 200 mounting plates and with all Domi snap-on mounting plates.

Packing

Boxes 150 pcs.

Pallets 3.600 pcs.

E min:

61 mm for Series 200 mounting plates.

70 mm for Domi snap-on mounting plates.

74 mm for Domi snap-on mounting plates with back cam.

Use the tables "Drillings and fixings" at page 29 to complete the code number of the desired hinge.

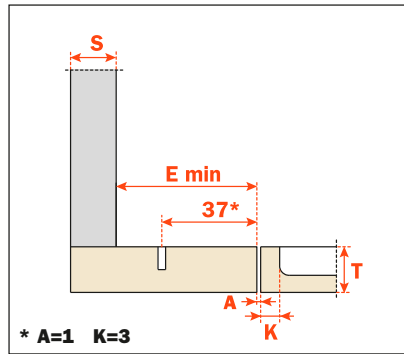
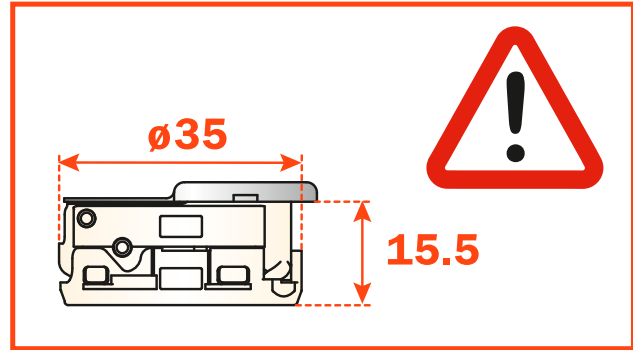

C2_BND9AC

Heights of mounting plates for every assembly.

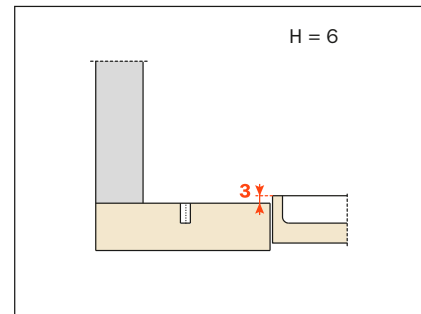
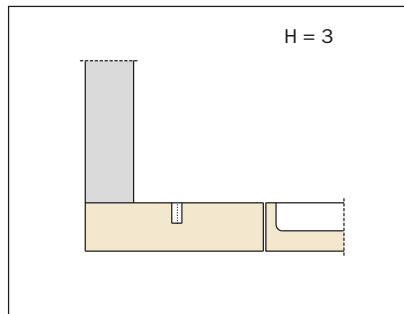
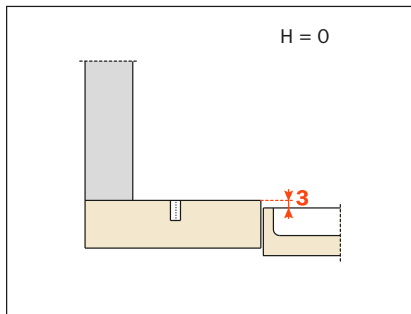



Technical information

Hinges with integrated soft-close mechanism in the hinge cup.

Crampon hinges.

For smaller spaces with 15x32 mm drilling.

Hinges for min. 18 mm thick doors.

15.5 mm deep cup.

94° opening.

Possible drilling distance on the door (K): from 3 to 9 mm.

Compatible with all traditional Series 200 mounting plates, 28x32 mm drilling.

NOT COMPATIBLE with Domi snap-on mounting plates.

Packing

Boxes 150 pcs.

Pallets 3.600 pcs.

Use the tables "Drillings and fixings" at page 29 to complete the code number of the desired hinge.

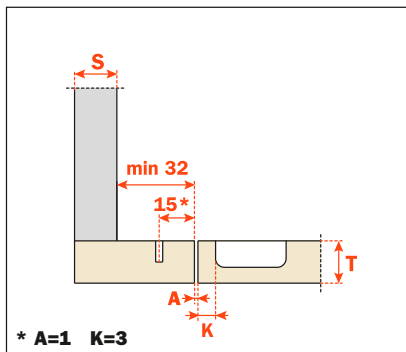
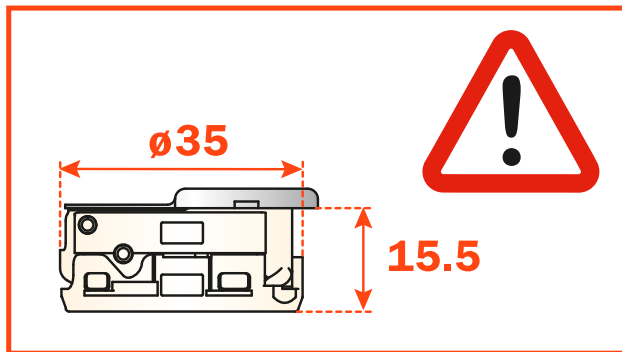

C2_BND9

Heights of mounting plates for every assembly.

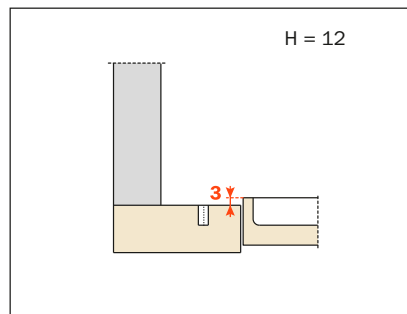
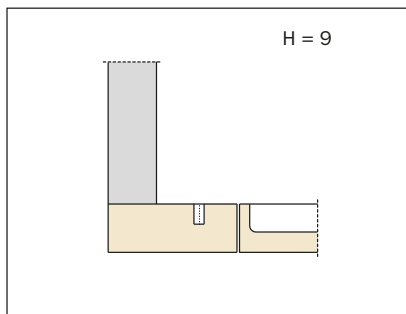
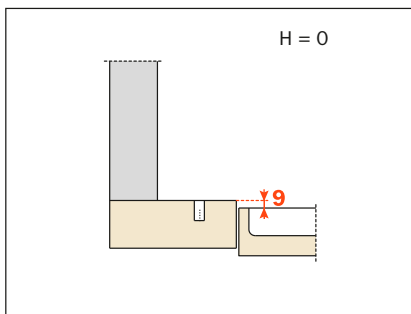

Silentia - For metal profiles



Silentia - For metal profiles



Technical information

Hinges with integrated soft-close mechanism in the hinge cup.

Hinges specially developed for use with metal profiles.

105° opening.

We recommend the use of countersunk flat head self tapping screws $\varnothing 2.9 \times 6.5$ UNI 6955 DIN 7982 to fix C1Z6 hinges.

Compatible with all traditional Series 200 mounting plates and with all Domi snap-on mounting plates.

Packing

Boxes 150 pcs.

Pallets 3.600 pcs.

Arm 0

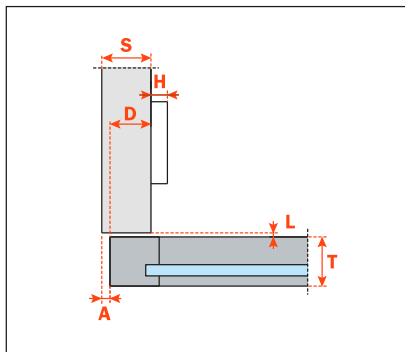

C1Z6AD9

Arm 5

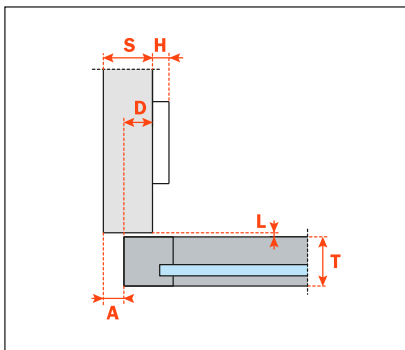

C1Z6DD9

Arm 9

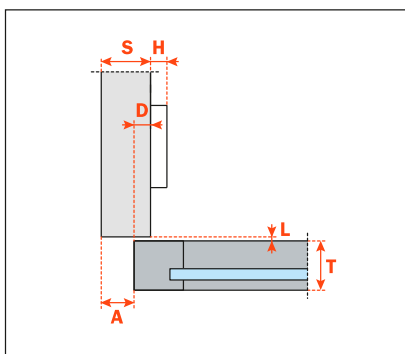

C1Z6GD9

Arm 17

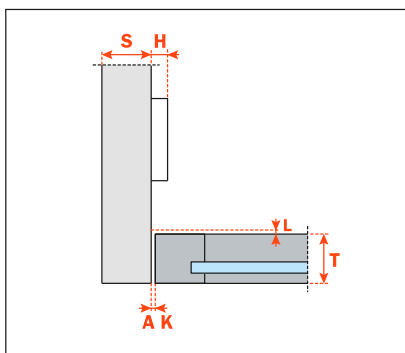

C1Z6PD9



Technical information

Hinges with integrated soft-close mechanism in the hinge cup.

For doors with positive angled assembly.

Hinges specially developed for use with metal profiles.

105° opening.

We recommend the use of countersunk flat head self tapping screws $\varnothing 2.9 \times 6.5$ UNI 6955 DIN 7982 to fix C1Z6 hinges.

Compatible with all traditional Series 200 mounting plates and with all Domi snap-on mounting plates.

Packing

Boxes 150 pcs.

Pallets 3.600 pcs.

Arm 30°

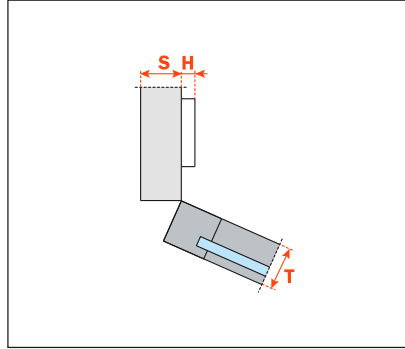

C1Z6ED9

Arm 45°

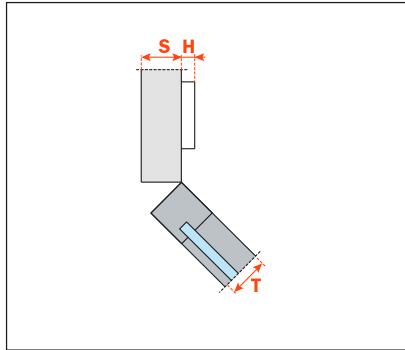

C1Z6MD9



Fancy cover for hinge (should be ordered separately)

D1Z6HSK



Technical information

Hinges with integrated soft-close mechanism in the hinge cup.

Crampon hinges.
For cabinet sides with 37x32 mm standard drilling.
Hinges specially developed for use with metal profiles.
 105° opening.

We recommend the use of countersunk flat head self tapping screws $\varnothing 2.9 \times 6.5$ UNI 6955 DIN 7982 to fix C1Z6 hinges.
 Compatible with all traditional Series 200 mounting plates and with all Domi snap-on mounting plates.

Packing

Boxes 150 pcs.
 Pallets 3.600 pcs.

E min:

61 mm for Series 200 mounting plates.
 70 mm for Domi snap-on mounting plates.
 74 mm for Domi snap-on mounting plates with back cam.

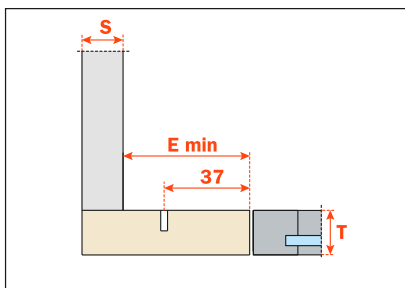

C1Z6ND9AC



Fancy cover for hinge (should be ordered separately)

D1Z6HSK



Technical information

Hinges with integrated soft-close mechanism in the hinge cup.

Crampon hinges.
For smaller spaces with 15x32 mm drilling.
Hinges specially developed for use with metal profiles.
 105° opening.

We recommend the use of countersunk flat head self tapping screws $\varnothing 2.9 \times 6.5$ UNI 6955 DIN 7982 to fix C1Z6 hinges.
 Compatible with all traditional Series 200 mounting plates, drilling 28x32 mm.

NOT COMPATIBLE with Domi snap-on mounting plates.

Packing

Boxes 150 pcs.
 Pallets 3.600 pcs.

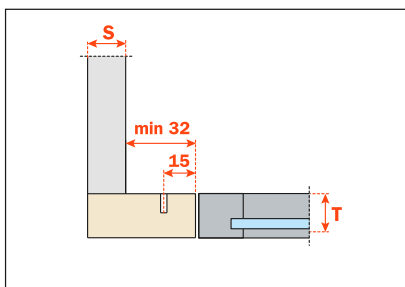

C1Z6ND9



Fancy cover for hinge (should be ordered separately)

D1Z6HSK

Drilling of the metal profile

Countersunk flat head self tapping screws $\varnothing 2.9 \times 6.5$ UNI 6955 - DIN 7982

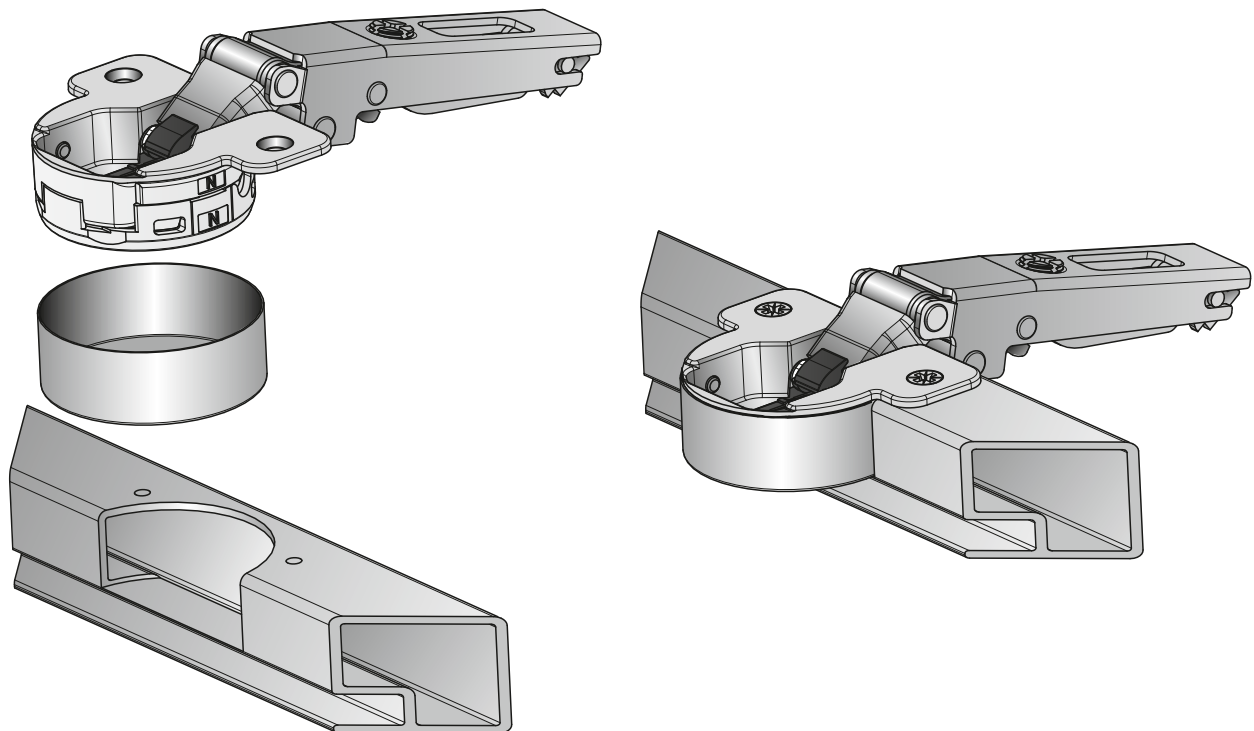
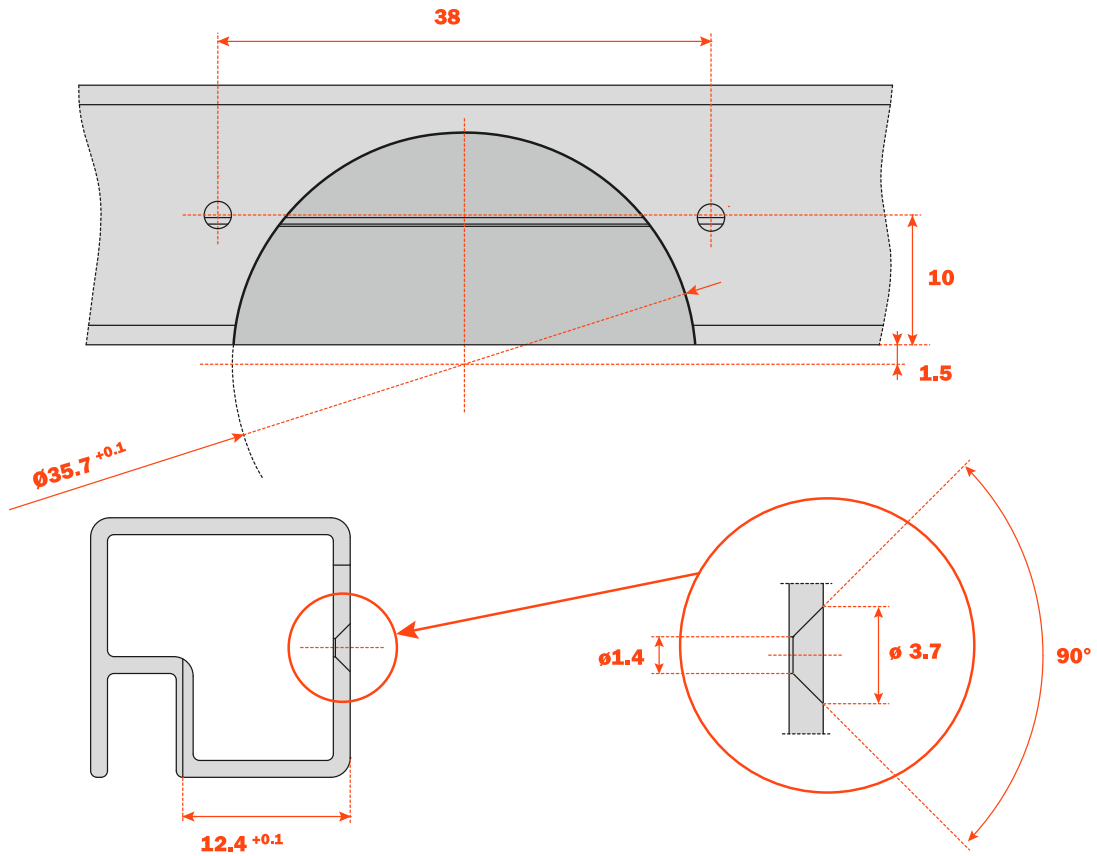

Silentia - Series 700



Silentia - Series 700

Hinges with integrated soft-close mechanism in the hinge cup.

Bright nickel plated steel cup and arm.
Dimensions of the Ø 35 mm cup.

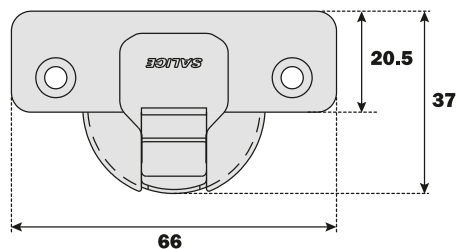

Constant "L" value of 0.7 mm (it does not change during side adjustment).

Approx. number of hinges required according to the door dimension and weight.

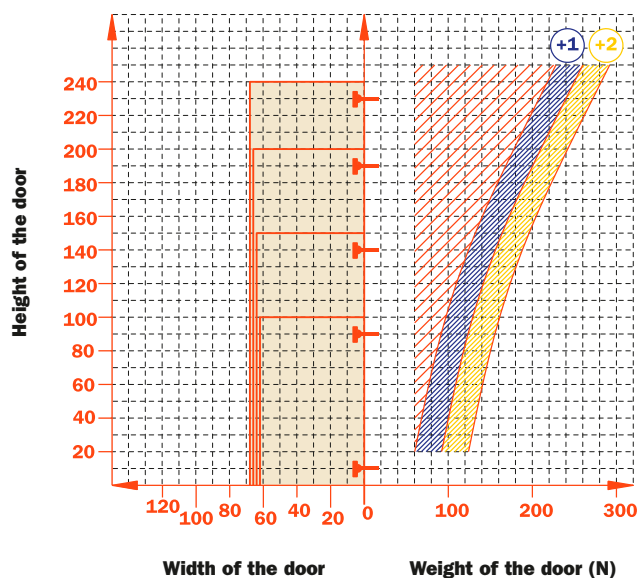

Adjustments

Compensated side adjustment from -1.5 mm to +4.5 mm.
 Height adjustment ±2 mm.
 Depth adjustment with Series 200 mounting plates +2.8 mm.
 Depth adjustment with Domi snap-on mounting plates from -0.5 mm to +2.8 mm.
 Anti-sliding safety stop.

Mounting plates

Symmetrical and asymmetrical bright nickel plated steel or die-cast Series 200 mounting plates.
 Snap-on assembly on Domi mounting plates.
 Positioning with pre-determined stop on traditional Series 200 mounting plates.

N.B. : Use POZIDRIVE No. 2 screwdrivers for all screws.

Wood screw		A	A	P	P	U	U
Rapido		6	6	7	7	2	2
Dowel		B	B	R	R	W	W
Logica		I	I	J	J	Q	Q

Use this table to identify the available drillings and fixings.

Fill the third position of the hinge code number with the letter or the number corresponding to your choice. I.e.: C7_6AD9.

↑
Fill this position with the chosen letter or number.

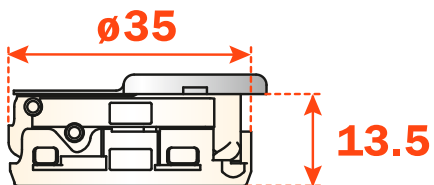

**110°, 155° opening
and complementary hinges**



Attention:
it is essential to drill the door as specified for the perfect functioning of the hinge.



Technical information

Hinges with integrated soft-close mechanism in the hinge cup.

**Hinges for min. 16 mm thick doors.
13.5 mm deep cup.**

110° opening.

Possible drilling distance on the door (K): from 3 to 6 mm.

Compatible with all traditional Series 200 mounting plates and with all Domi snap-on mounting plates.

Space needed to open the door

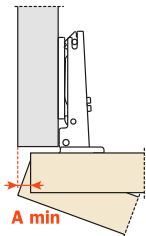

	T=	16	17	18	19	20	21	22	23	24	25	26
K=3	A=	0.7	0.9	1.1	1.3	1.6	1.9	2.2	2.6	3.2	4.4	5.7
K=4	A=	0.6	0.8	1.1	1.3	1.6	1.8	2.2	2.5	2.9	3.4	4.7
K=5	A=	0.6	0.8	1.0	1.3	1.5	1.8	2.1	2.4	2.8	3.2	3.7
K=6	A=	0.6	0.8	1.0	1.2	1.5	1.8	2.1	2.4	2.7	3.1	3.6

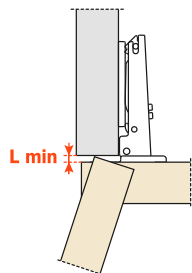

	T=	16	17	18	19	20	21	22	23	24	25	26
K=3	L=	0.0	0.0	0.0	0.0	0.0	0.0	0.0	0.2	0.4	0.6	0.9
K=4	L=	0.0	0.0	0.0	0.3	0.5	0.7	0.9	1.1	1.4	1.6	1.8
K=5	L=	0.6	0.8	1.0	1.2	1.5	1.7	1.9	2.1	2.4	2.6	2.8
K=6	L=	1.5	1.8	2.0	2.2	2.4	2.7	2.9	3.1	3.3	3.6	3.8

The above values are calculated on the assumption that the doors have square edges. They are reduced if the doors have radiussed edges.

Projection of the door

Projection of the door from the cabinet side at the max. opening. The figures are based on a straight arm hinge, H=0 mm thickness of mounting plate and K value = 3 mm.

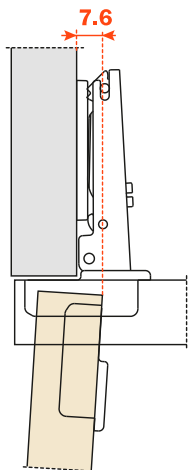

“C” value

With this formula you can obtain the max. thickness of the moulded door that can be opened without touching adjacent carcass sides, doors or walls, whilst bearing in mind the above L-K-T values.

$$C = 22.5 + K + A$$

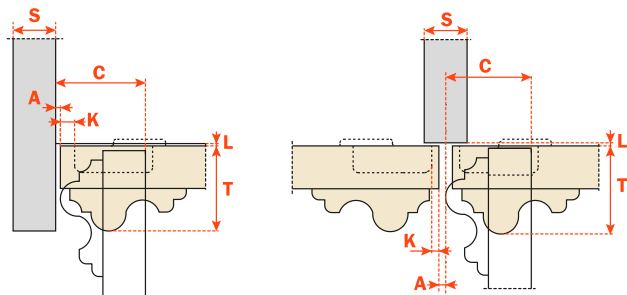

Packing

Boxes 300 pcs.
Pallets 7.200 pcs.

Use these formulas to determine the type of hinge arm, the drilling distance "K" and the height of the mounting plate "H" which is necessary to solve each application problem.

Use the tables "Drillings and fixings" at page 47 to complete the code number of the desired hinge.

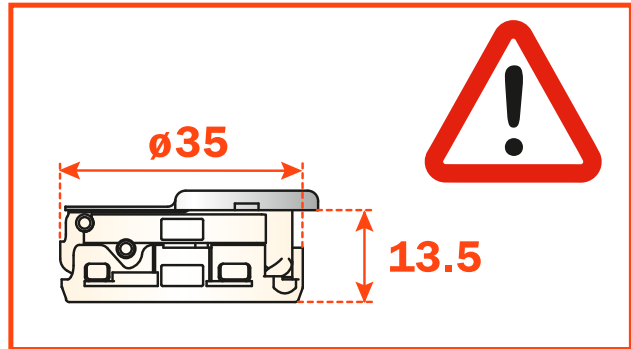
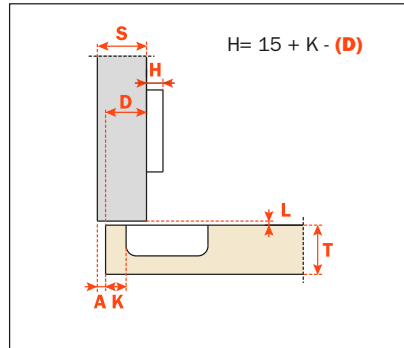
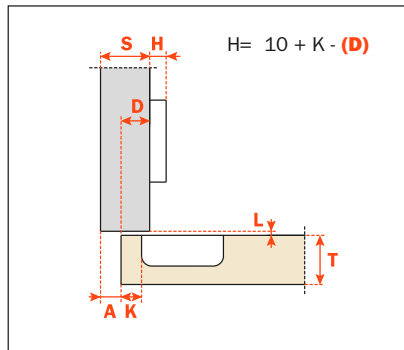
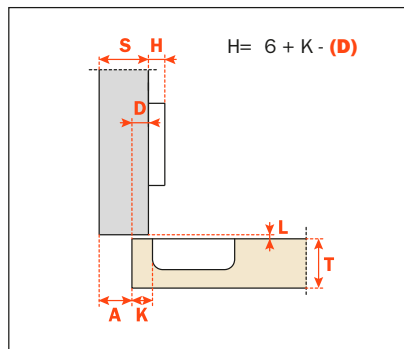
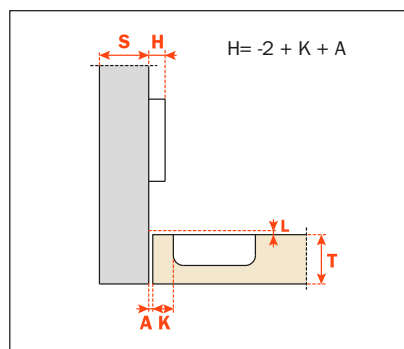
**Arm 0****C7_6AD9****Arm 5****C7_6DD9****Arm 9****C7_6GD9****Arm 17****C7_6PD9**

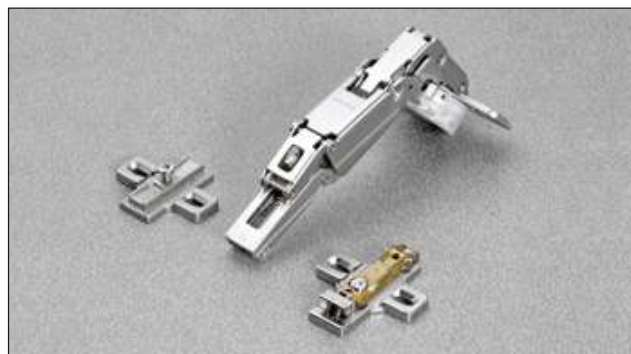

Technical information

Hinges with integrated soft-close mechanism in the hinge cup.

**Hinges for thick doors 16 mm min.
13.5 mm deep cup.**

155° opening.
Possible drilling distance on the door (K): from 3 to 8 mm.
Compatible with all traditional Series 200 mounting plates and with all Domi snap-on mounting plates.

Space needed to open the door

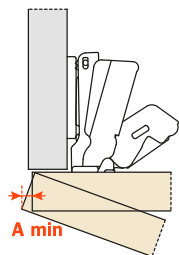

	T=	16	18	20	22
K=3	A=	0.0	0.0	0.3	1.2
K=4	A=	0.0	0.4	0.4	1.3
K=5	A=	0.0	0.1	0.5	1.6
K=6	A=	0.0	0.1	1.2	3.0
K=7	A=	0.0	0.1	0.7	2.5
K=8	A=	0.0	0.0	0.6	1.9

The above values are calculated on the assumption that the doors have square edges. They are reduced if the doors have radiussed edges.

“C” value

For spaces with removable components. The door combined with a mounting plate H=0 and a straight arm hinge opens at 90° with lateral door protrusion of 2 mm.

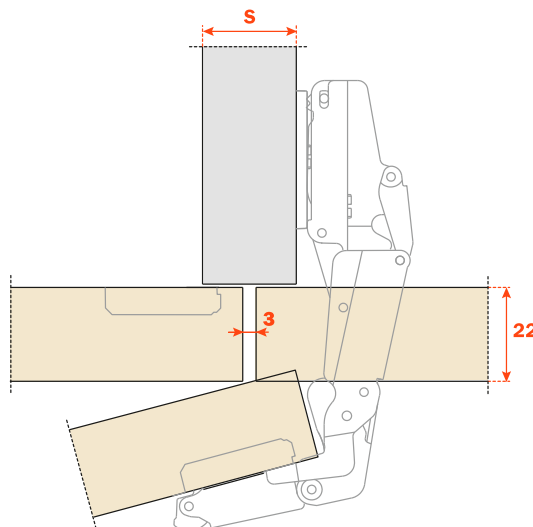
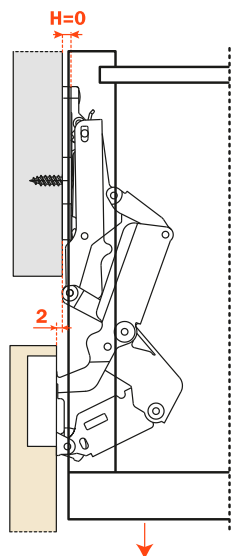

Packing

Boxes 100 pcs.
Pallets 2.400 pcs.

Use these formulas to determine the type of hinge arm, the drilling distance "K" and the height of the mounting plate "H" which is necessary to solve each application problem.

To limit the opening of the hinge, see page 354 chapter "Accessories".

Use the tables "Drillings and fixings" at page 47 to complete the code number of the desired hinge.

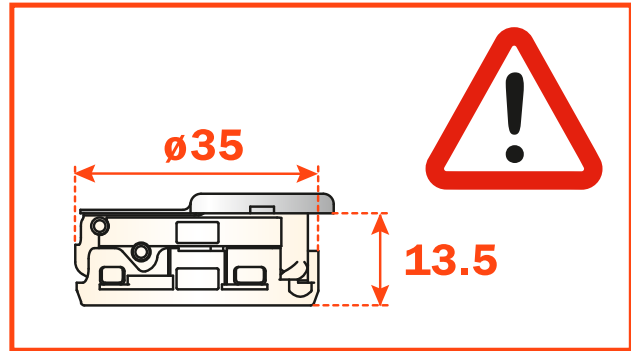
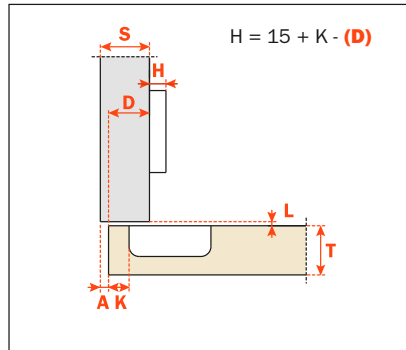
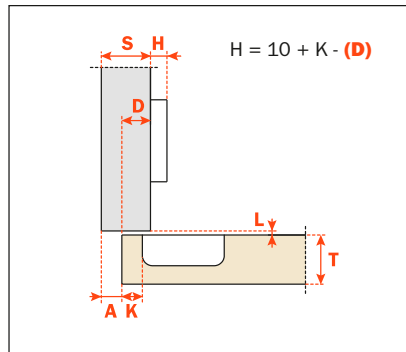
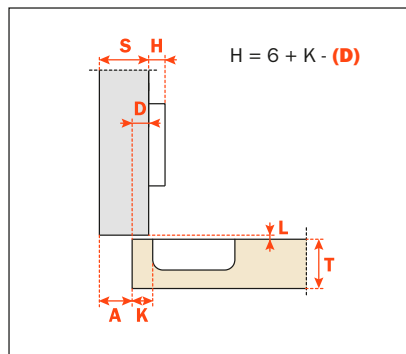
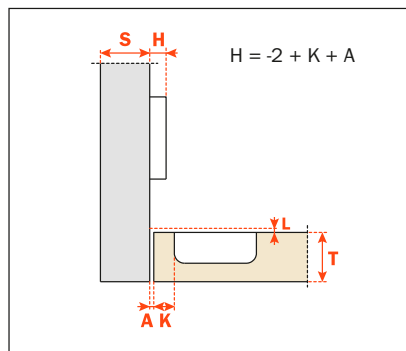
**Arm 0****C2_MAD9****Arm 5****C2_MDD9****Arm 9****C2_MGD9****Arm 17****C2_MPD9**



Technical information

Hinges with integrated soft-close mechanism in the hinge cup.

**For wooden doors with positive angled assembly.
Hinges for min. 16 mm thick doors.**

13.5 mm deep cup.

110° opening.

Possible drilling distance on the door (K): from 3 to 6 mm.

Compatible with all traditional Series 200 mounting plates and with all Domi snap-on mounting plates.

Packing

Boxes 150 pcs.

Pallets 3.600 pcs.

The solution of assembly problems where doors are mounted at a positive angle requires the verification of drilling distances by a practical trial. Please do not hesitate to consult our technical support department for assistance.

Use the tables "Drillings and fixings" at page 47 to complete the code number of the desired hinge.

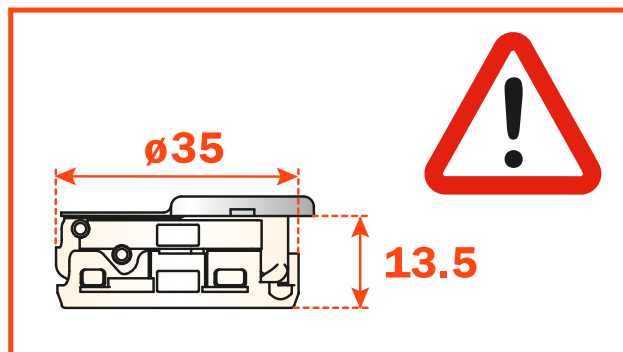

Arm 15°

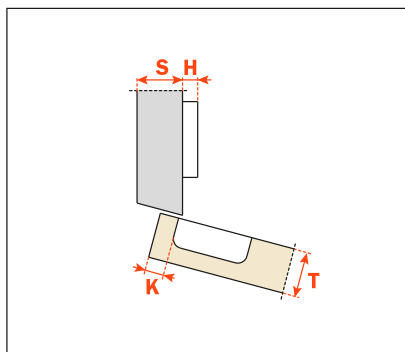

C7_6ZD9

Arm 24°

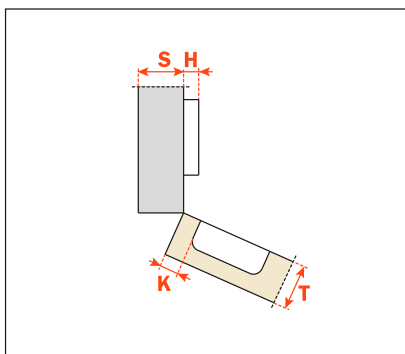

C7_6UD9

Arm 30°

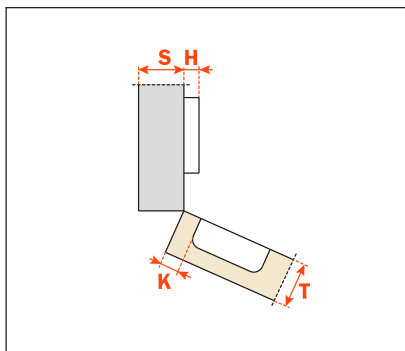

C7_6ED9

Arm 30°

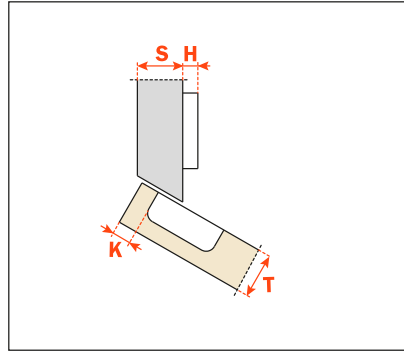

C7_6TD9

Arm 37°

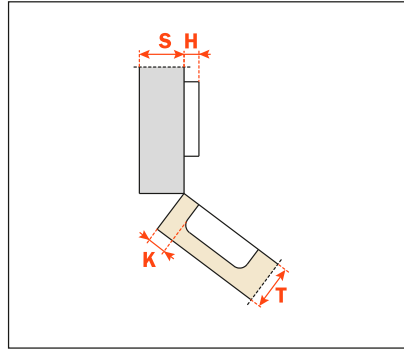

C7_6KD9

Arm 45°

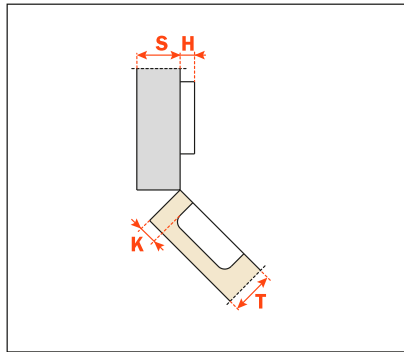

C7_6MD9

Arm 45°

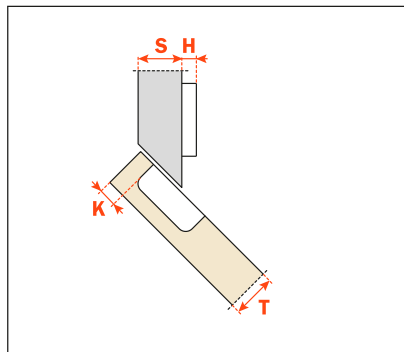
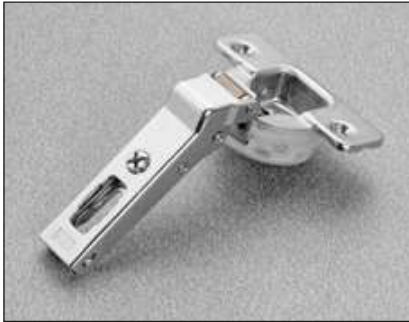

C7_6VD9

Arm 45°

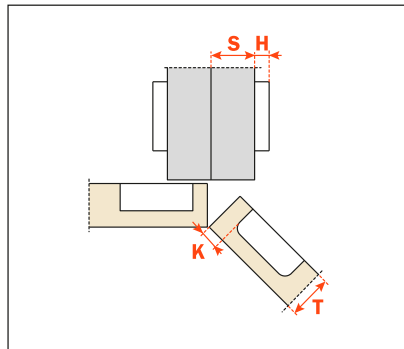

C7_6MD9AC



Technical information

Hinges with integrated soft-close mechanism in the hinge cup.

For wooden doors with negative angled assembly.

Hinges for min. 16 mm thick doors.

13.5 mm deep cup.

110° opening.

Possible drilling distance on the door (K): from 3 to 6 mm.

Compatible with all traditional Series 200 mounting plates and with all Domi snap-on mounting plates.

Packing

Boxes 150 pcs.

Pallets 3.600 pcs.

The solution of assembly problems where doors are mounted at a negative angle requires the verification of drilling distances by a practical trial. Please do not hesitate to consult our technical support department for assistance.

Use the tables "Drillings and fixings" at page 47 to complete the code number of the desired hinge.

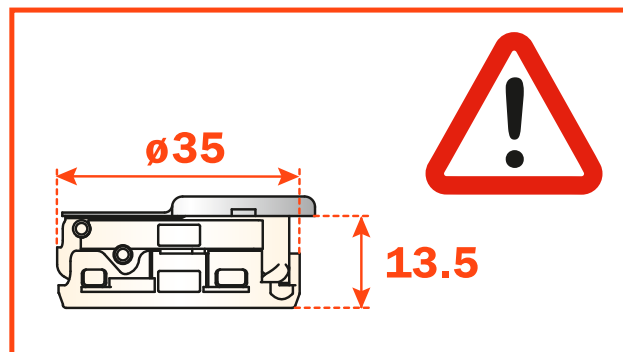

Arm **-30°**

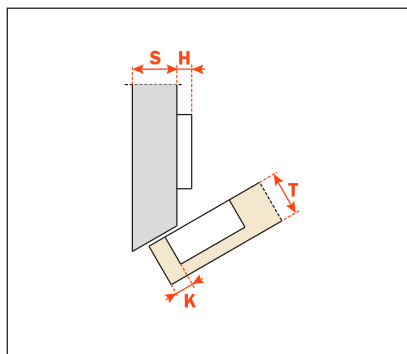

C7_6WD9



Technical information

Hinges with integrated soft-close mechanism in the hinge cup.

Crampon hinges.

For cabinet sides with 37x32 mm standard drilling.

Hinges for min. 16 mm thick doors.

13.5 mm deep cup.

110° opening.

Possible drilling distance on the door (K): from 3 to 6 mm.

Compatible with all traditional Series 200 mounting plates and with all Domi snap-on mounting plates.

Packing

Boxes 150 pcs.

Pallets 3.600 pcs.

E min:

61 mm for Series 200 mounting plates.

70 mm for Domi snap-on mounting plates.

74 mm for Domi snap-on mounting plates with back cam.

Use the tables "Drillings and fixings" at page 47 to complete the code number of the desired hinge.

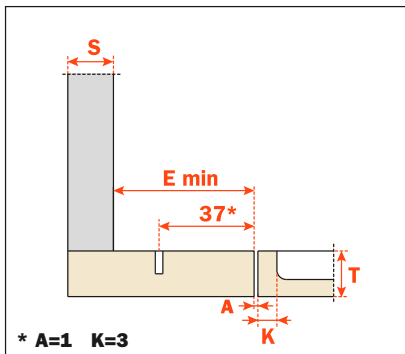
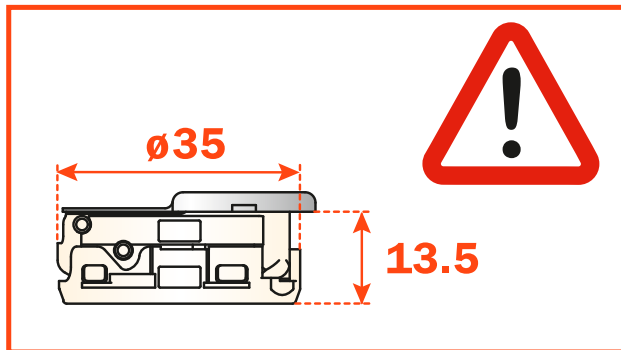

C7_6ND9AC

Heights of mounting plates for every assembly.

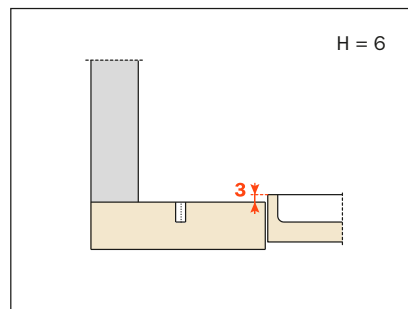
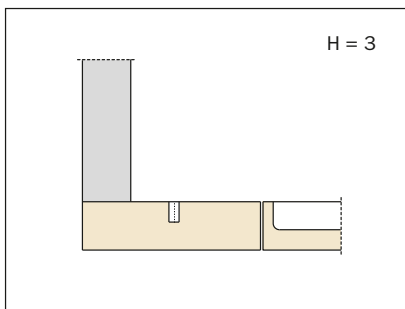
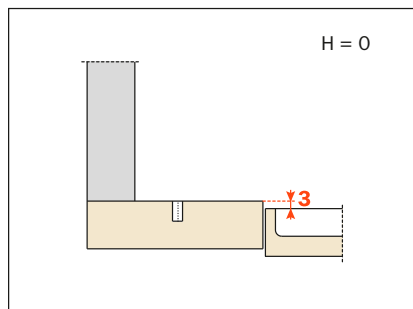



Technical information

Hinges with integrated soft-close mechanism in the hinge cup.

**Long crampton hinges.
Hinges for min. 16 mm thick doors.
13.5 mm deep cup.**

110° opening.
Possible drilling distance on the door (K): from 3 to 6 m.
Compatible with all traditional Series 200 mounting plates and with all Domi snap-on mounting plates.

Packing

Boxes 150 pcs.
Pallets 3.600 pcs.

E min:

61 mm for Series 200 mounting plates.
70 mm for Domi snap-on mounting plates.
74 mm for Domi snap-on mounting plates with back cam.

Use the tables "Drillings and fixings" at page 47 to complete the code number of the desired hinge.

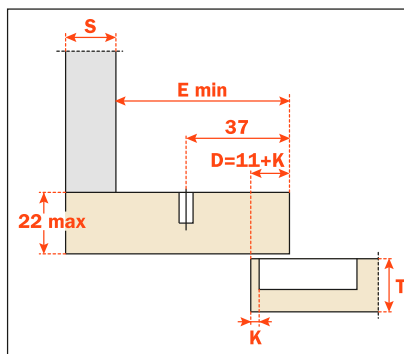
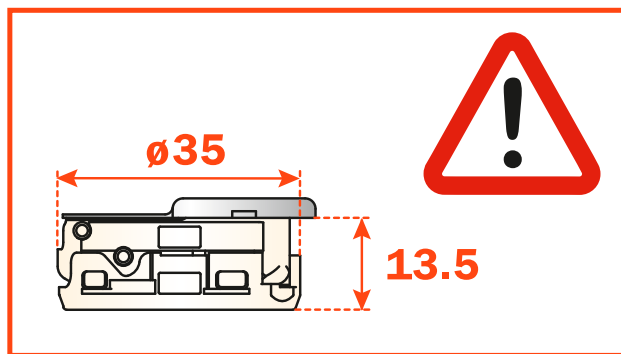

C7_6ND9AM

Heights of mounting plates for every assembly.

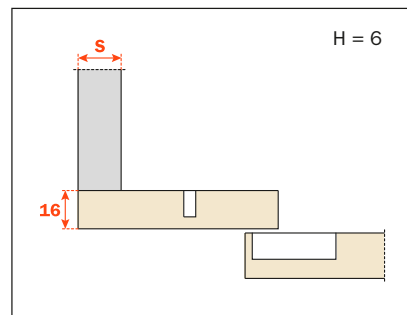
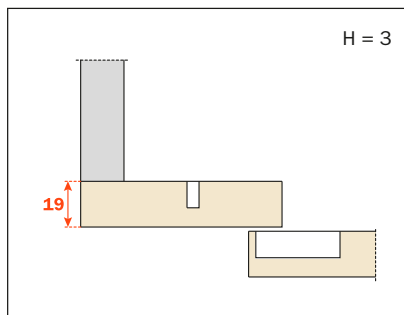
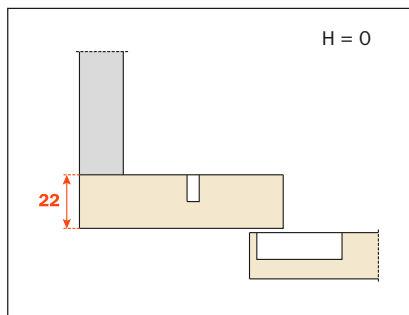



Technical information

Hinges with integrated soft-close mechanism in the hinge cup.

Crampon hinges.

For smaller spaces with 15x32 mm drilling.

Hinges for min. 16 mm thick doors.

13.5 mm deep cup.

110° opening.

Possible drilling distance on the door (K): from 3 to 6 mm.

Compatible with all traditional Series 200 mounting plates,

28x32 mm drilling.

NOT COMPATIBLE with Domi snap-on mounting plates.

Packing

Boxes 150 pcs.

Pallets 3.600 pcs.

Use the tables "Drillings and fixings" at page 47 to complete the code number of the desired hinge.

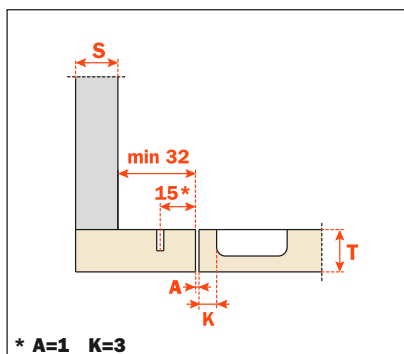
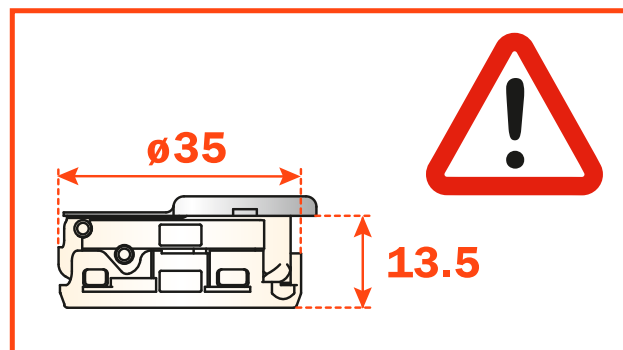

C7_6ND9

Heights of mounting plates for every assembly.

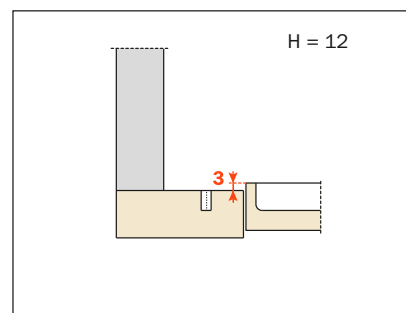
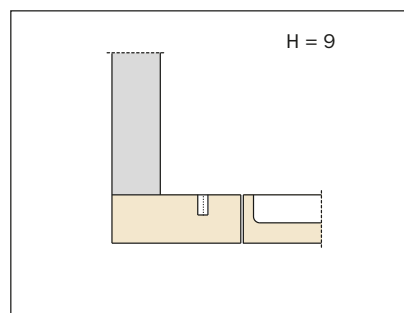
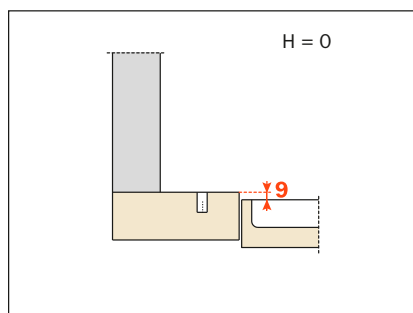

Silentia - Series 800



Hinges with integrated soft-close mechanism in the hinge cup.

Bright nickel plated steel cup and arm.
Dimensions of the \varnothing 35 mm cup.

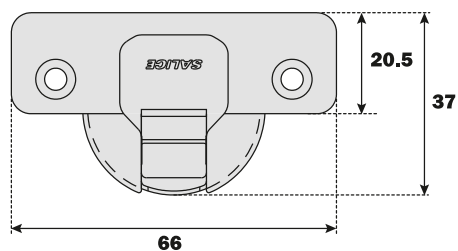

Approx. number of hinges required according to the door dimension and weight.

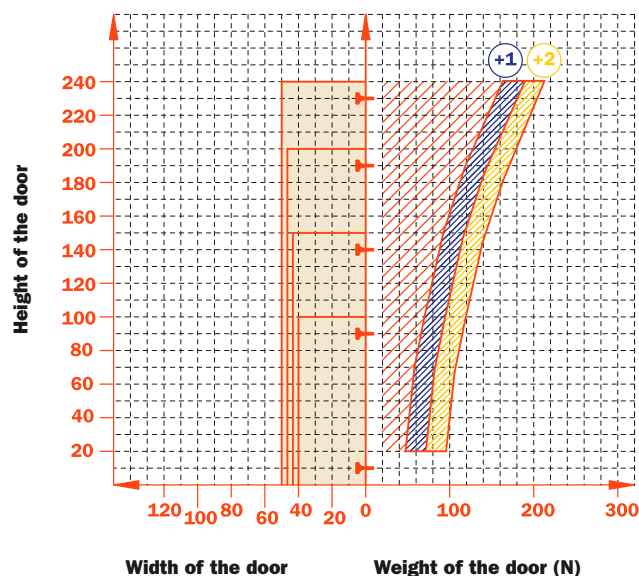





Adjustments

Side adjustment from -1.5 mm to +4.5 mm.
Height adjustment ± 2 mm.
Depth adjustment from -1.5 mm to +3 mm.

Mounting plates

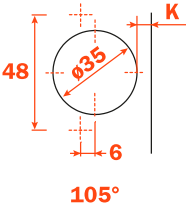
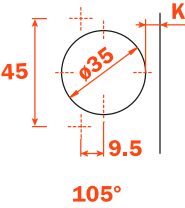
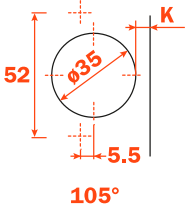
Symmetrical and asymmetrical bright nickel plated steel Series 200 mounting plates.
NOT COMPATIBLE with Series 200 mounting plates with negative height.

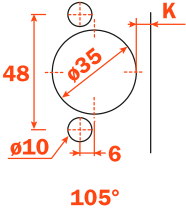
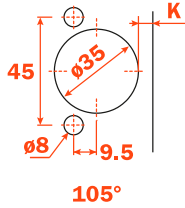
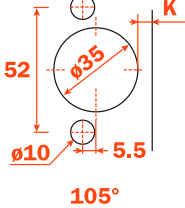
N.B. : Use POZIDRIVE No. 2 screwdrivers for all screws.

			
Wood screw 	A	P	U
			
Rapido 	6	7	2
Dowel 	B	R	W

Use this table to identify the available drillings and fixings.
 Fill the third position of the hinge code number with the letter or the number corresponding to your choice. I.e.: C8_6CD9.

↑
 Fill this position with the chosen letter or number.

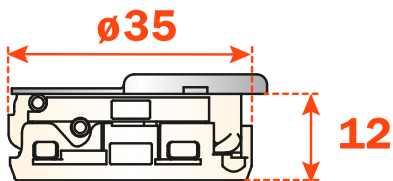

105° opening



Attention:
 it is essential to drill the door as specified for the perfect functioning of the hinge.



Technical information

Hinges with integrated soft-close mechanism in the hinge cup.

**Hinges for doors of small weight and thickness.
12 mm deep cup.**

105° opening.

Possible drilling distance on the door (K): from 3 to 6 mm.

Compatible with all traditional steel Series 200 mounting plates.

Space needed to open the door

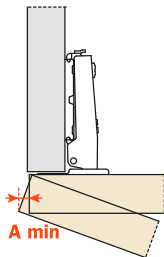

	T=	15	16	17	18	19	20
K=3	A=	1.0	1.0	1.2	1.4	1.6	1.9
K=4	A=	0.9	1.0	1.2	1.3	1.5	1.8
K=5	A=	0.9	1.0	1.1	1.2	1.5	1.8
K=6	A=	0.9	1.0	1.1	1.2	1.4	1.7

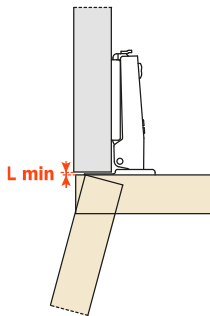

	T=	15	16	17	18	19	20
K=3	L=	0.0	0.0	0.0	0.0	0.1	0.3
K=4	L=	0.4	0.6	0.7	0.9	1.1	1.2
K=5	L=	1.0	1.0	1.2	1.8	2.0	2.0
K=6	L=	1.6	1.8	2.0	2.1	2.3	2.5

The above values are calculated on the assumption that the doors have square edges. They are reduced if the doors have radiussed edges.

Projection of the door

Projection of the door from the cabinet side at the max. opening. The figures are based on a straight arm hinge, H=0 mm thickness of mounting plate and K value = 3 mm.

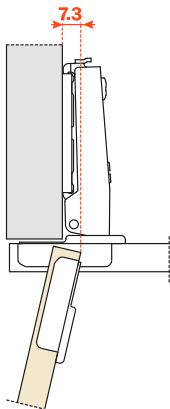

“C” value

With this formula you can obtain the max. thickness of the moulded door that can be opened without touching adjacent carcass sides, doors or walls, whilst bearing in mind the above L-K-T values.

$$C = 20.5 + K + A$$

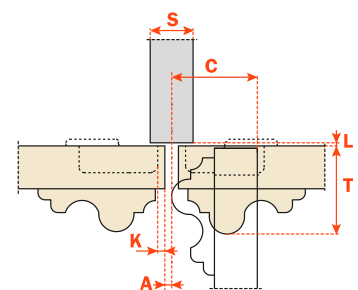
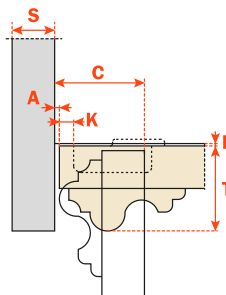

Packing

Boxes 300 pcs.
Pallets 7.200 pcs.

Use these formulas to determine the type of hinge arm, the drilling distance "K" and the height of the mounting plate "H" which is necessary to solve each application problem.

Use the tables "Drillings and fixings" at page 61 to complete the code number of the desired hinge.

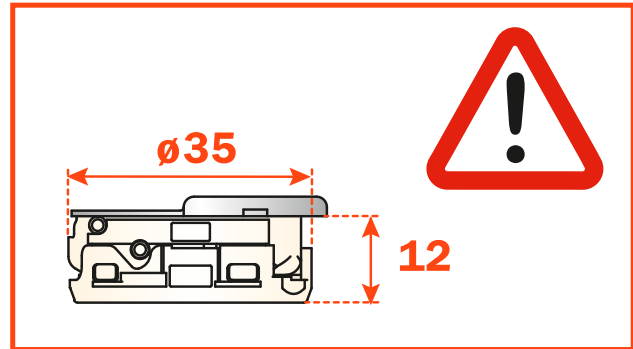

Arm 0

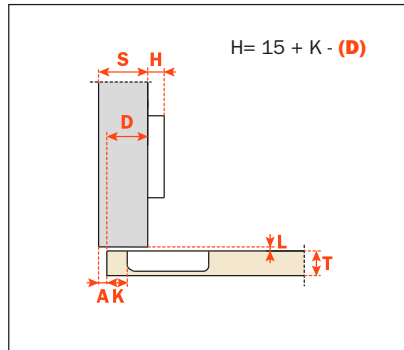
**C8_6CD9**

Arm 5

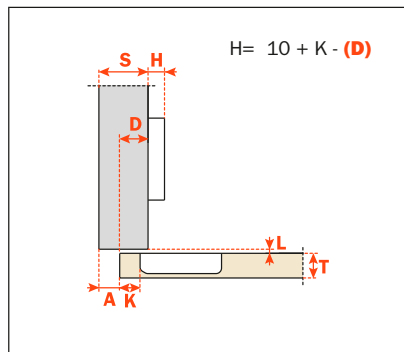
**C8_6JD9**

Arm 9

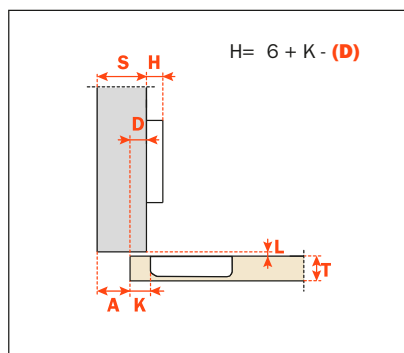
**C8_6LD9**

Arm 17

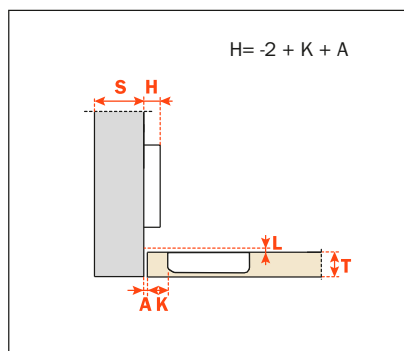
**C8_6SD9**

Silentia - Series 900



Hinges with integrated soft-close mechanism in the hinge cup.

Bright nickel plated steel cup and arm.
Dimensions of the Ø 35 mm cup.

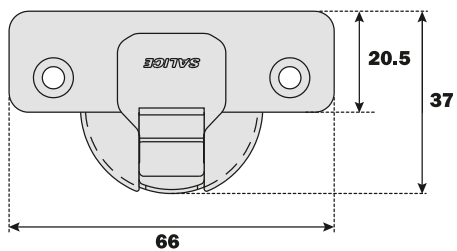

Approx. number of hinges required according to the door dimension and weight.

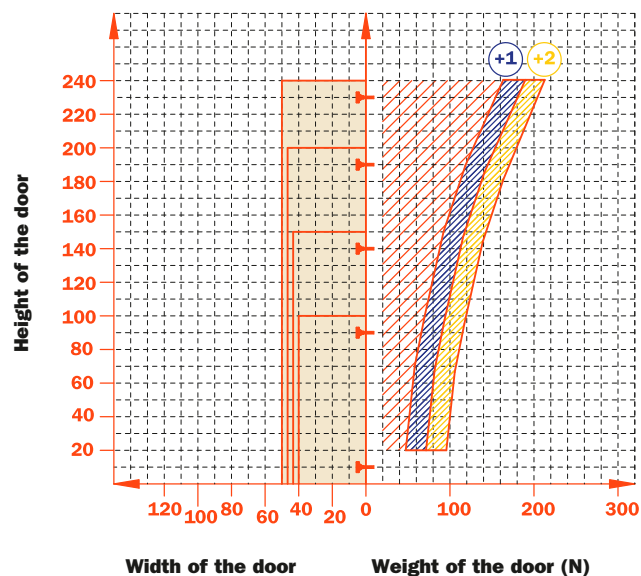





Adjustments

Side adjustment from -1.5 mm to +4 mm.
 Height adjustment ± 2 mm.
 Depth adjustment +2.5 mm.

Mounting plates

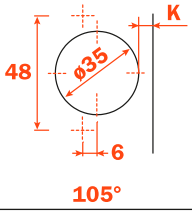
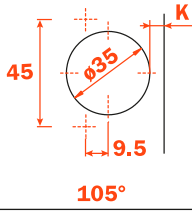
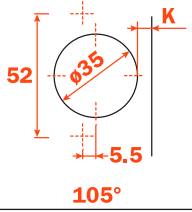
Symmetrical and asymmetrical bright nickel plated steel or die-cast Series 200 mounting plates.
NOT COMPATIBLE with Series 200 mounting plates with negative height.

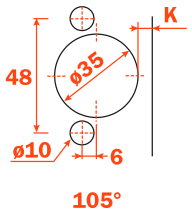
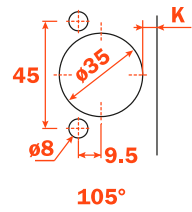
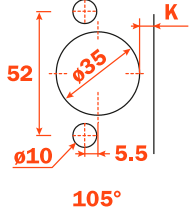
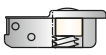
N.B. : Use POZIDRIVE No. 2 screwdrivers for all screws.

			
Wood screw 	A	P	U
			
Rapido 	6	7	2
Dowel 	B	R	W

Use this table to identify the available drillings and fixings.
 Fill the third position of the hinge code number with the letter or the number corresponding to your choice. I.e.: C9_6CD9.

↑
 Fill this position with the chosen letter or number.

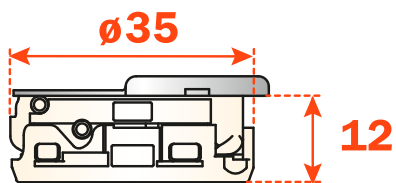

105° opening



Attention:
 it is essential to drill the door as specified for the perfect functioning of the hinge.



Technical information

Hinges with integrated soft-close mechanism in the hinge cup.

**Hinges for doors of small weight and thickness.
12 mm deep cup.**

105° opening.
Possible drilling distance on the door (K): from 3 to 6 mm.
Compatible with all traditional Series 200 mounting plates.
NOT COMPATIBLE with Domi snap-on mounting plates.

Space needed to open the door

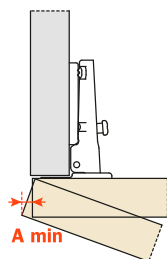

	T=	15	16	17	18	19	20
K=3	A=	1.0	1.0	1.2	1.4	1.6	1.9
K=4	A=	0.9	1.0	1.2	1.3	1.5	1.8
K=5	A=	0.9	1.0	1.1	1.2	1.5	1.8
K=6	A=	0.9	1.0	1.1	1.2	1.4	1.7

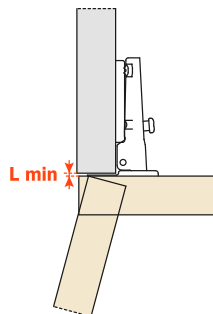

	T=	15	16	17	18	19	20
K=3	L=	0.0	0.0	0.0	0.0	0.1	0.3
K=4	L=	0.4	0.6	0.7	0.9	1.1	1.2
K=5	L=	1.0	1.0	1.2	1.8	2.0	2.0
K=6	L=	1.6	1.8	2.0	2.1	2.3	2.5

The above values are calculated on the assumption that the doors have square edges. They are reduced if the doors have radiussed edges.

Projection of the door

Projection of the door from the cabinet side at the max. opening. The figures are based on a straight arm hinge, H=0 mm thickness of mounting plate and K value = 3 mm.

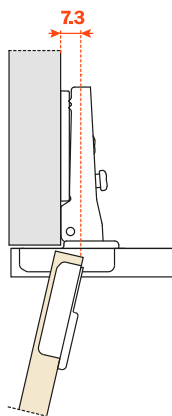

“C” value

With this formula you can obtain the max. thickness of the moulded door that can be opened without touching adjacent carcass sides, doors or walls, whilst bearing in mind the above L-K-T values.

$$C = 20.5 + K + A$$

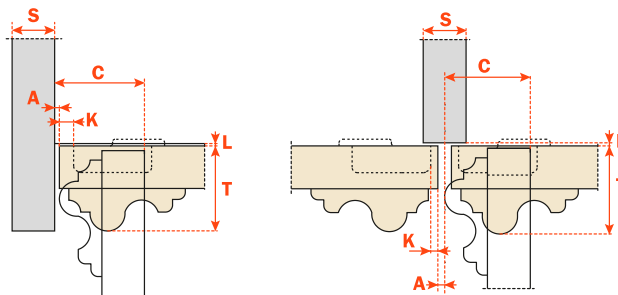

Packing

Boxes 300 pcs.
Pallets 7.200 pcs.

Use these formulas to determine the type of hinge arm, the drilling distance "K" and the height of the mounting plate "H" which is necessary to solve each application problem.

Use the tables "Drillings and fixings" at page 67 to complete the code number of the desired hinge.

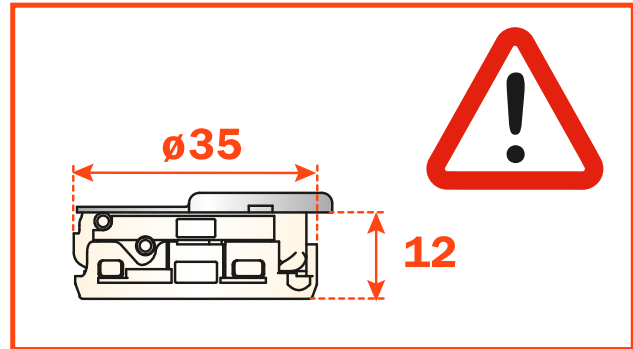

Arm 0

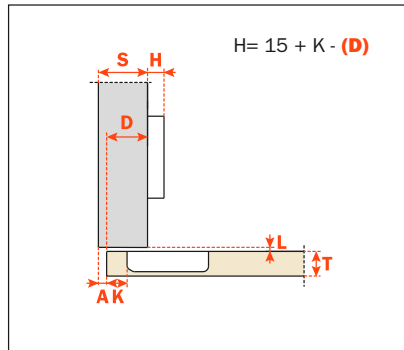
**C9_6CD9**

Arm 5

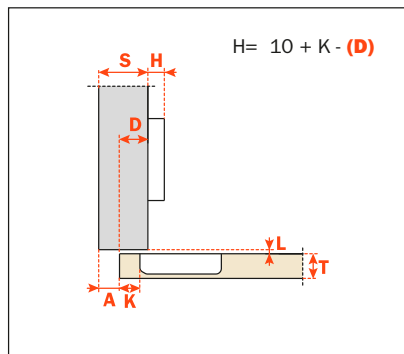
**C9_6JD9**

Arm 9

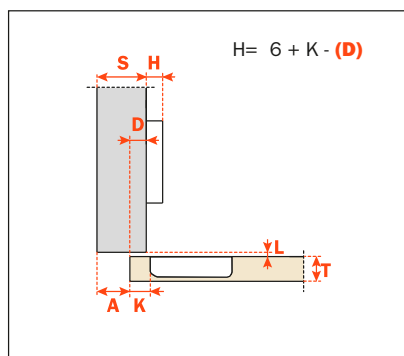
**C9_6LD9**

Arm 17

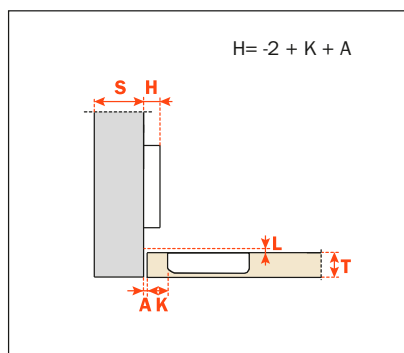
**C9_6SD9**

Series 100

Series 100



Hinges for thinner door.

Bright nickel plated steel cup and arm.

Dimensions of the Ø 35 mm cup.

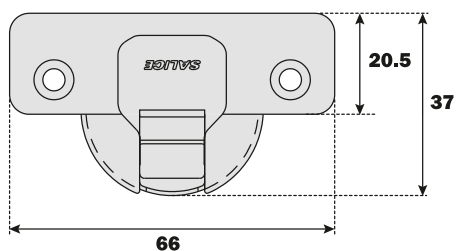

Constant "L" value of 0.7 mm (it does not change during side adjustment).

Approx. number of hinges required according to the door dimension and weight.

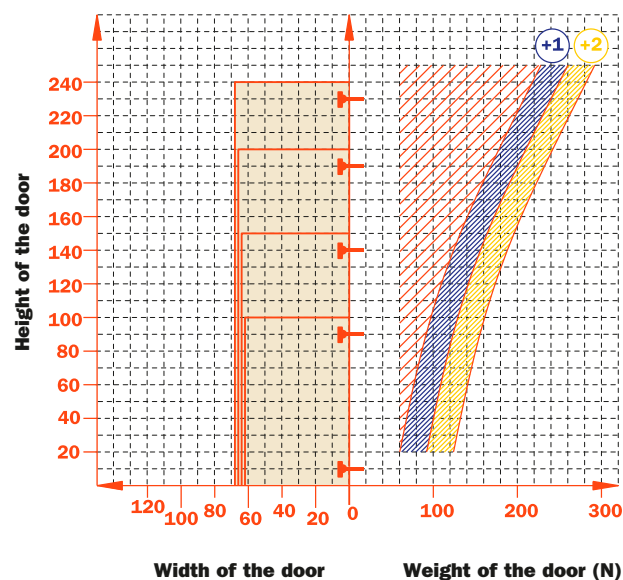

Adjustments

Compensated side adjustment from -1.5 mm to +4.5 mm.
 Height adjustment ±2 mm.
 Depth adjustment with Series 200 mounting plates +2.8 mm.
 Depth adjustment with Domi snap-on mounting plates from -0.5 mm to +2.8 mm.
 Anti-sliding safety stop.

Mounting plates

Symmetrical and asymmetrical bright nickel plated steel or die-cast Series 200 mounting plates.
 Snap-on assembly on Domi mounting plates.
 Positioning with pre-determined stop on traditional Series 200 mounting plates.

N.B. : Use POZIDRIVE No. 2 screwdrivers for all screws.

Wood screw		105°	155°		
	A		A	P	P
		105°	155°		
				P	P
		105°	155°		
				U	U

Dowel		105°	155°
	B		B

**Use this table to identify the available drillings and fixings.
 Fill the third position of the hinge code number with the letter or the number corresponding to your choice. I.e.: C1_6A99.**

↑
 Fill this position with the chosen letter or number.



Technical information

For min. 10 mm thick doors.

8 mm deep metal cup.

105° opening.

Possible drilling distance on the door (K): from 3 to 6 mm.

Compatible with all traditional Series 200 mounting plates and with all Domi snap-on mounting plates.

Space needed to open the door

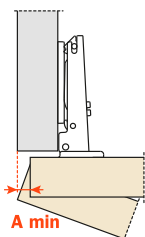

T=	10	11	12	13	14	15	16	17	18	19	20
K=3 A=	0.2	0.3	0.4	0.6	0.8	1.0	1.3	1.6	1.9	2.3	2.7
K=4 A=	0.2	0.3	0.4	0.6	0.8	1.0	1.3	1.6	1.9	2.2	2.6
K=5 A=	0.1	0.3	0.4	0.6	0.8	1.0	1.2	1.5	1.8	2.1	2.5
K=6 A=	0.1	0.2	0.4	0.5	0.7	1.0	1.2	1.5	1.8	2.1	2.4

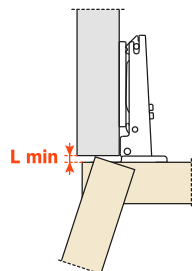

T=	10	11	12	13	14	15	16	17	18	19	20
K=3 L=	0.0	0.0	0.0	0.0	0.0	0.0	0.0	0.0	0.0	0.1	0.3
K=4 L=	0.0	0.0	0.0	0.0	0.2	0.4	0.6	0.7	0.9	1.1	1.2
K=5 L=	0.5	0.7	0.9	1.0	1.2	1.4	1.5	1.7	1.9	2.1	2.2
K=6 L=	1.5	1.7	1.8	2.0	2.2	2.4	2.5	2.7	2.9	3.1	3.2

The above values are calculated on the assumption that the doors have square edges. They are reduced if the doors have radiused edges.

Projection of the door

Projection of the door from the cabinet side at the max. opening. The figures are based on a straight arm hinge, H=0 mm thickness of mounting plate and K value = 3 mm.

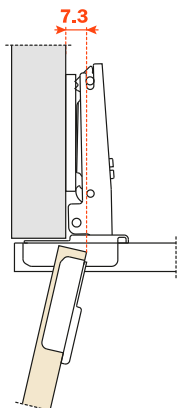

“C” value

With this formula you can obtain the max. thickness of the moulded door that can be opened without touching adjacent carcass sides, doors or walls, whilst bearing in mind the above L-K-T values.

$$C = 20.5 + K + A$$

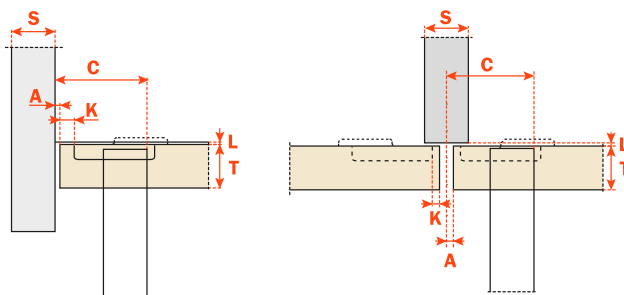

Packing

Boxes 300 pcs.
Pallets 7.200 pcs.

CA sprung hinge
CL unsprung hinge

Use these formulas to determine the type of hinge arm, the drilling distance "K" and the height of the mounting plate "H" which is necessary to solve each application problem.

Use the tables "Drillings and fixings" at page 73 to complete the code number of the desired hinge.

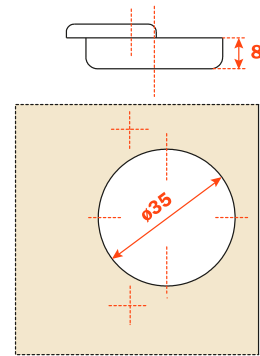
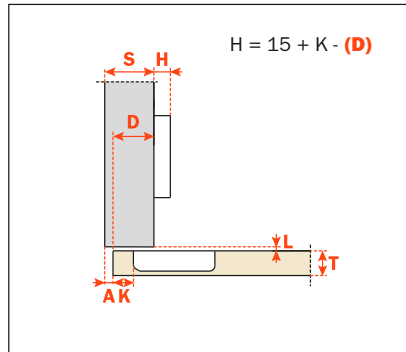
**Arm 0**

CA - C1_6A99
CL - C1_4A99

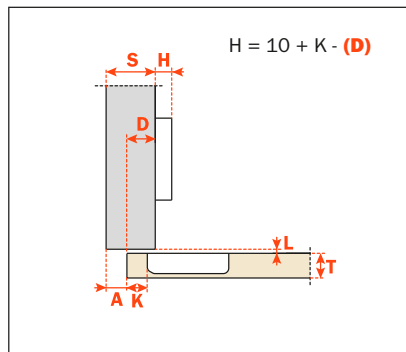
Arm 5

CA - C1_6D99
CL - C1_4D99

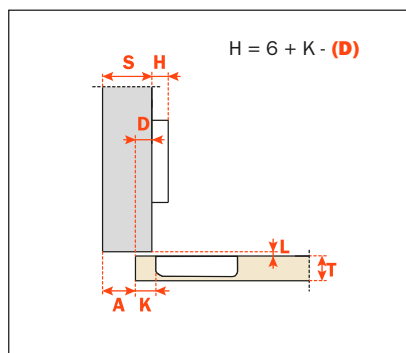
Arm 9

CA - C1_6G99
CL - C1_4G99

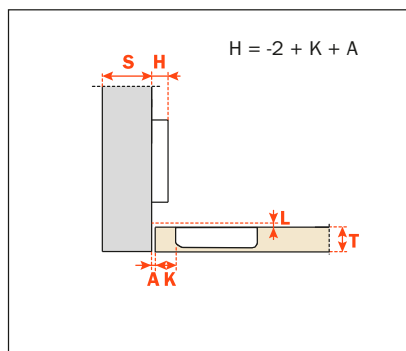
Arm 17

CA - C1_6P99
CL - C1_4P99

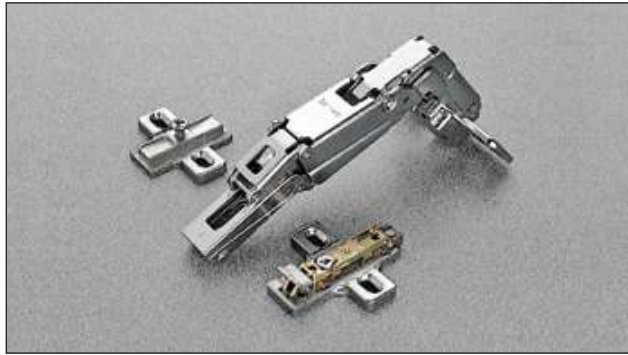

Technical information

For min. 10 mm thick doors.

8 mm deep die-cast cup.

155° opening.

Possible drilling distance on the door (K): from 3 to 8 mm.

Compatible with all traditional Series 200 mounting plates and with all Domi snap-on mounting plates.

Space needed to open the door

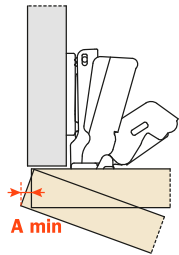

	T=	16	18	20	22
K=3	A=	0.0	0.0	0.3	1.2
K=4	A=	0.0	0.4	0.4	1.3
K=5	A=	0.0	0.1	0.5	1.6
K=6	A=	0.0	0.1	1.2	3.0
K=7	A=	0.0	0.1	0.7	2.5
K=8	A=	0.0	0.1	0.6	1.9

The above values are calculated on the assumption that the doors have square edges. They are reduced if the doors have radiussed edges.

“C” value

For spaces with removable components. The door combined with a mounting plate H=0 and a straight arm hinge opens at 90° with lateral door protrusion of 2 mm.

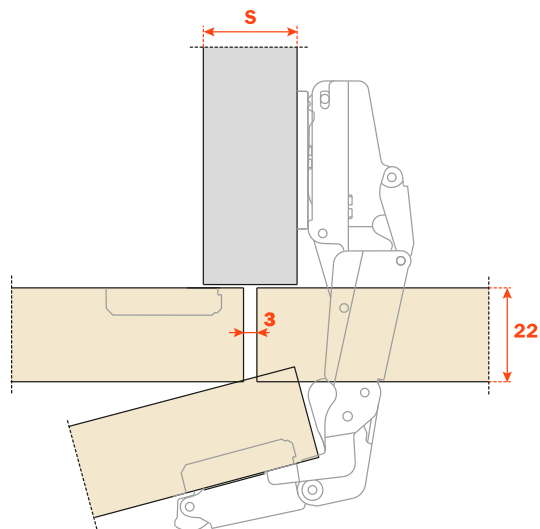
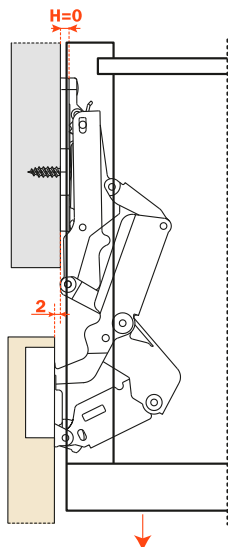

Packing

Boxes 100 pcs.
Pallets 2.400 pcs.

Use these formulas to determine the type of hinge arm, the drilling distance "K" and the height of the mounting plate "H" which is necessary to solve each application problem.

To limit the opening of the hinge, see page 354 chapter "Accessories".

Use the tables "Drillings and fixings" at page 73 to complete the code number of the desired hinge.

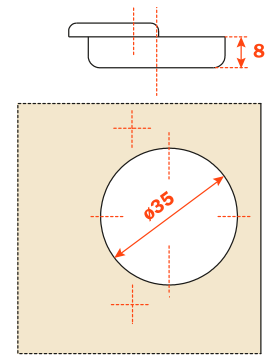
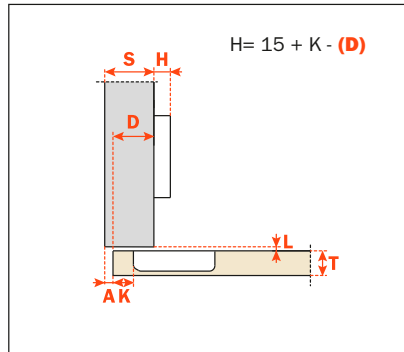
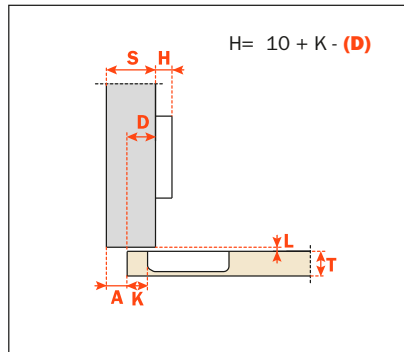
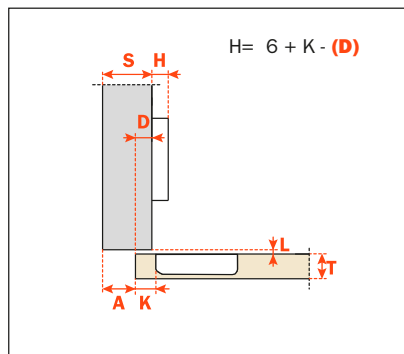
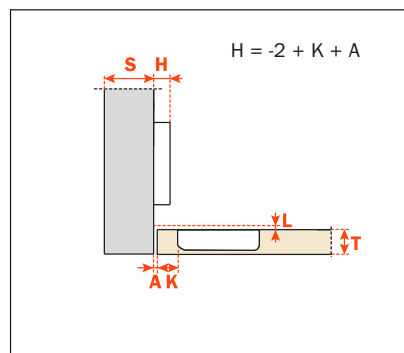
**Arm 0****CA - C2_MA99****Arm 5****CA - C2_MD99****Arm 9****CA - C2_MG99****Arm 17****CA - C2_MP99**



Technical information

**Hinges for wooden doors with positive angled assembly.
For min. 10 mm thick doors.**

8mm deep metal cup.

105° opening.

Possible drilling distance on the door (K): from 3 to 6 mm.

Compatible with all traditional Series 200 mounting plates and with all Domi snap-on mounting plates.

Packing

Boxes 150 pcs.

Pallets 3.600 pcs.

CA sprung hinge

The solution of assembly problems where doors are mounted at a positive angle requires the verification of drilling distances by a practical trial. Please do not hesitate to consult our technical support department for assistance.

Use the tables "Drillings and fixings" at page 73 to complete the code number of the desired hinge.

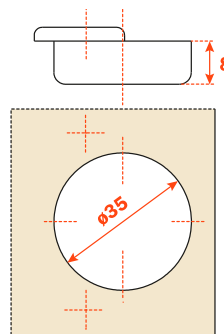

Arm 15°

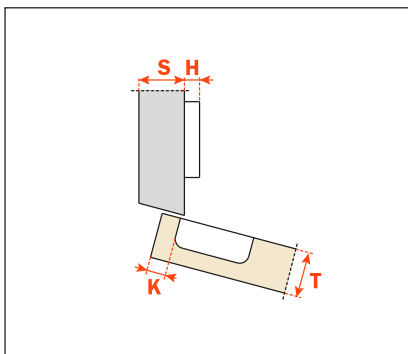

CA - C1_6Z99

Arm 24°

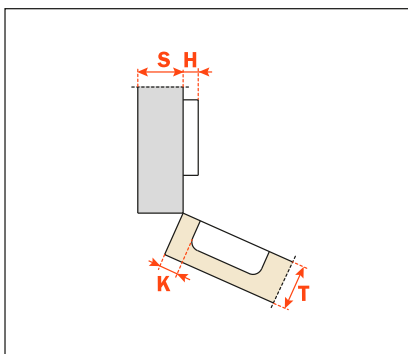

CA - C1_6U99

Arm 30°

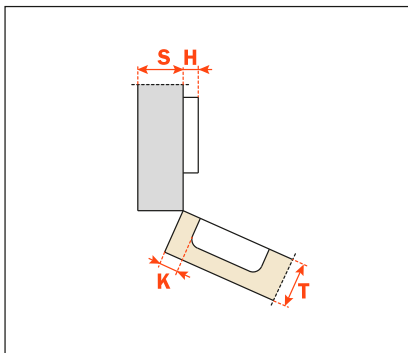

CA - C1_6E99

Arm 30°

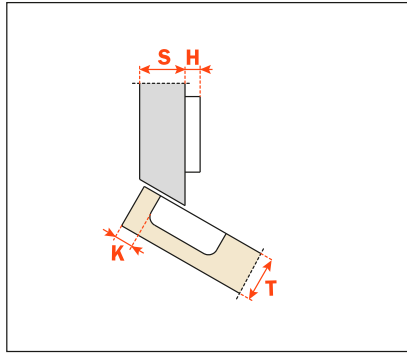

CA - C1_6T99

Arm 37°

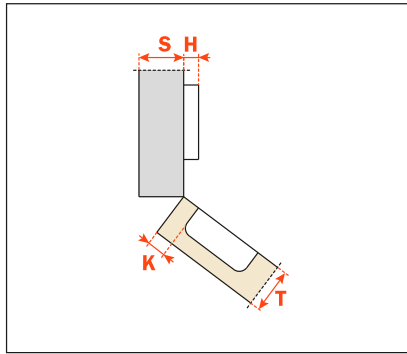

CA - C1_6K99

Arm 45°

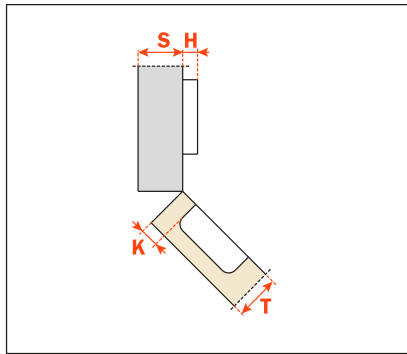

CA - C1_6M99

Arm 45°

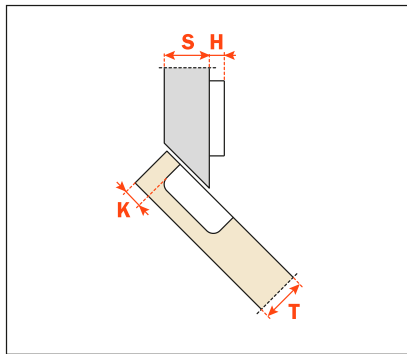

CA - C1_6V99

Arm 45°

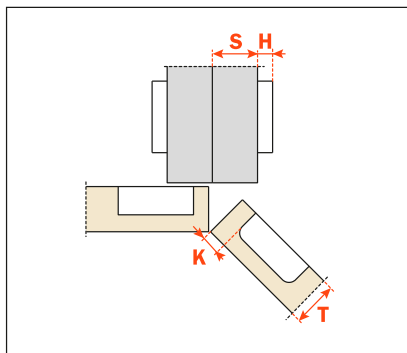

CA - C1_6M99AC



Technical information

Crampon hinges.
For cabinet sides with 37x32 mm standard drilling.
For min. 10 mm thick doors.
 8 mm deep metal cup.
 105° opening.
 Possible drilling distance on the door (K): from 3 to 6 mm.
 Compatible with all traditional Series 200 mounting plates and with all Domi snap-on mounting plates.

Packing

Boxes 150 pcs.
 Pallets 3.600 pcs.

CA sprung hinge

E min:

61 mm for Series 200 mounting plates.
 70 mm for Domi snap-on mounting plates.
 74 mm for Domi snap-on mounting plates with back cam.

Use the tables "Drillings and fixings" at page 73 to complete the code number of the desired hinge.

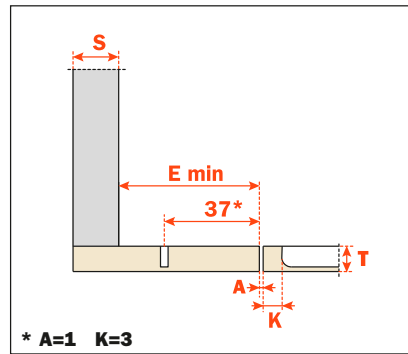
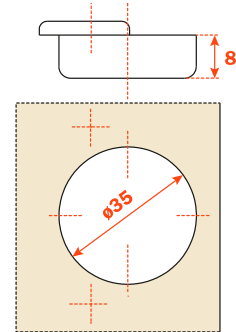

CA - C1_6N99AC

Heights of mounting plates for every assembly.

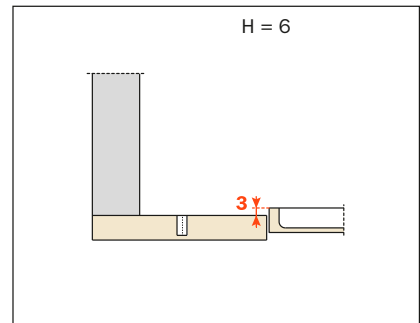
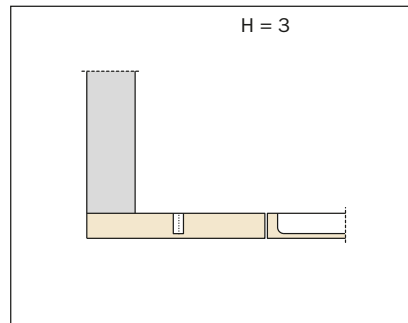
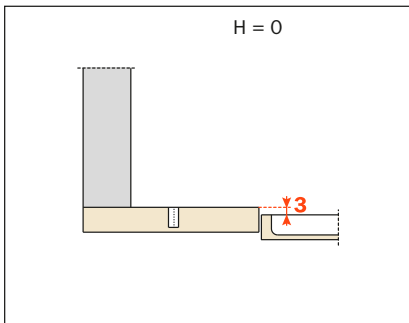

Series 200



Series 200

The Series 200 make up an integrated system of hinges developed to provide a solution to any situation involving concealed hinges.

Bright nickel plated steel cup and arm.

Dimensions of the Ø 35 mm cup.

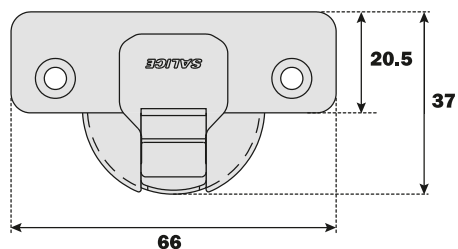

Constant "L" value of 0.7 mm (it does not change during side adjustment).

Approx. number of hinges required according to the door dimension and weight.

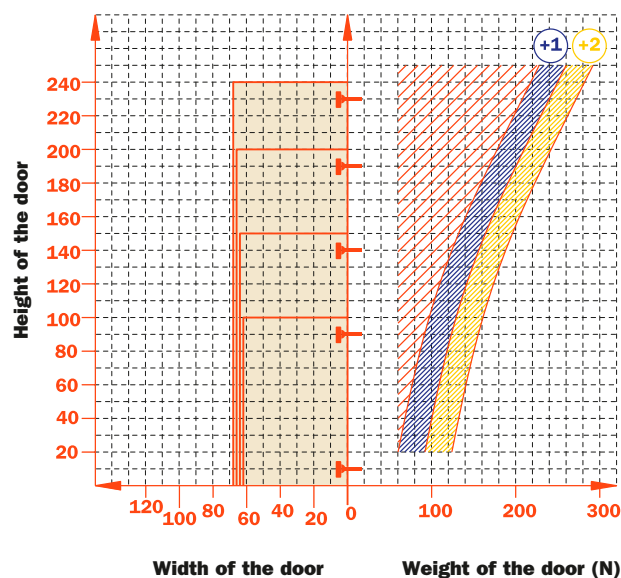

Adjustments

- Compensating side adjustment from -1.5 mm to +4.5 mm.
- Height adjustment ± 2 mm.
- Depth adjustment with Series 200 mounting plates +2.8 mm.
- Depth adjustment with Domi snap-on mounting plates from -0.5 mm to +2.8 mm.
- Anti-sliding safety stop.

Mounting plates

- Symmetrical and asymmetrical bright nickel plated steel or die-cast Series 200 mounting plates.
- Snap-on assembly on Domi mounting plates.
- Positioning with pre-determined stop on traditional Series 200 mounting plates.

N.B. : Use POZIDRIVE No. 2 screwdrivers for all screws.

		94°	110°	120°	155° 165°	94°	110°	120°	155° 165°	94°	110°	120°	155° 165°
Wood screw		A	A	A	A	P	P	P	P	U	U	U	U

		94°	110°	120°	155° 165°	94°	110°	120°	155° 165°	94°	110°	120°	155° 165°
Rapido		6	6	6	6	7	7	7	7	2	2	2	2
Dowel		B	B	B	B	R	R	R	R	W	W	W	W
Logica		I	I	I	I	J	J	J	J	Q	Q	Q	Q

Use this table to identify the available drillings and fixings.
 Fill the third position of the hinge code number with the letter or the number corresponding to your choice. I.e.: C2_BA99.

↑
 Fill this position with the chosen letter or number.

Series 200 - For thicker doors - 94° opening



Technical information

For thicker doors, max. 35 mm, with special profiles.

11 mm deep metal cup.

94° opening.

Possible drilling distance on the door (K): from 3 to 9 mm.

Compatible with all traditional Series 200 mounting plates and with all Domi snap-on mounting plates.

Space needed to open the door

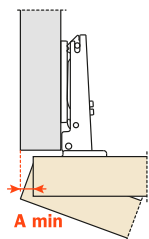

T=	19	20	21	22	23	24	25	26	27	28	29	30	31	32	33	34	35
K=3	A= 0.1	0.2	0.3	0.4	0.5	0.7	0.8	1.0	1.6	2.6	3.5	4.5	5.4	6.4	7.4	8.3	9.3
K=4	A= 0.1	0.2	0.3	0.4	0.5	0.7	0.8	1.0	1.2	1.9	2.8	3.8	4.7	5.7	6.6	7.6	8.6
K=5	A= 0.1	0.2	0.3	0.4	0.5	0.7	0.8	1.0	1.2	1.4	2.2	3.1	4.1	5.0	5.9	6.9	7.8
K=6	A= 0.1	0.2	0.3	0.4	0.5	0.6	0.8	1.0	1.2	1.4	1.7	2.6	3.5	4.4	5.3	6.2	7.2
K=7	A= 0.1	0.2	0.3	0.4	0.5	0.6	0.8	1.0	1.1	1.3	1.6	2.1	3.0	3.8	4.7	5.6	6.5
K=8	A= 0.1	0.2	0.3	0.4	0.5	0.6	0.8	0.9	1.1	1.3	1.6	1.8	2.5	3.3	4.2	5.1	6.0
K=9	A= 0.1	0.2	0.3	0.4	0.5	0.6	0.8	0.9	1.1	1.3	1.5	1.8	2.1	2.9	3.7	4.6	5.4

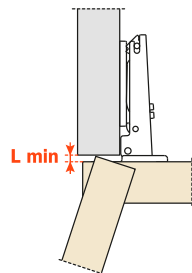

K=	3	4	5	6	7	8	9
L=	0.0	0.0	0.0	0.0	0.0	0.3	1.3

The above values are calculated on the assumption that the doors have square edges. They are reduced if the doors have radiussed edges.

Projection of the door

Projection of the door from the cabinet side at the max. opening. The figures are based on a straight arm hinge, H=0 mm thickness of mounting plate and K value = 3 mm.

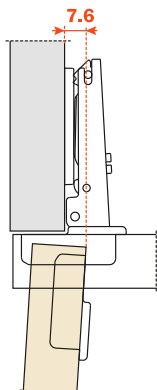

"C" value

With this formula you can obtain the max. thickness of the moulded door that can be opened without touching adjacent carcass sides, doors or walls, whilst bearing in mind the above L-K-T values.

$$C = 23 + K + A$$

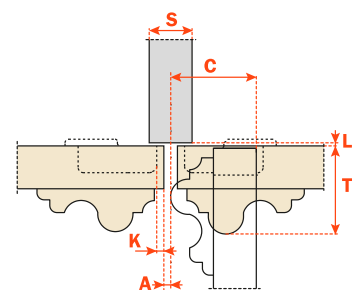
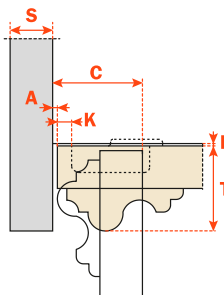

Packing

Boxes 300 pcs.
Pallets 7.200 pcs.

CA sprung hinge
CL unsprung hinge

Use these formulas to determine the type of hinge arm, the drilling distance "K" and the height of the mounting plate "H" which is necessary to solve each application problem.

Use the tables "Drillings and fixings" at page 83 to complete the code number of the desired hinge.

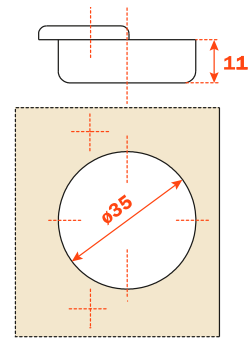
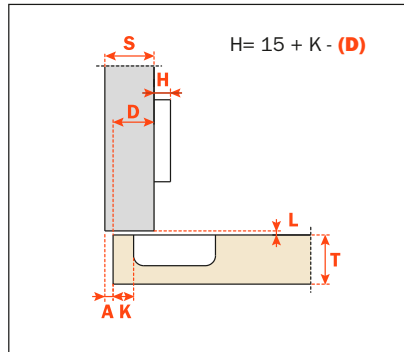
**Arm 0**

CA - C2_BA99
CL - C2_AA99

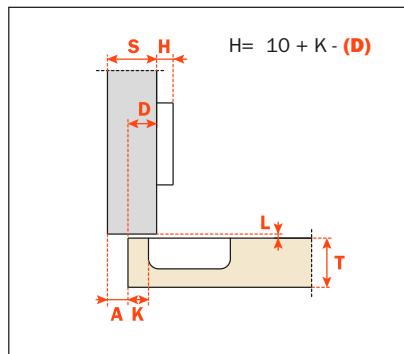
Arm 5

CA - C2_BD99
CL - C2_AD99

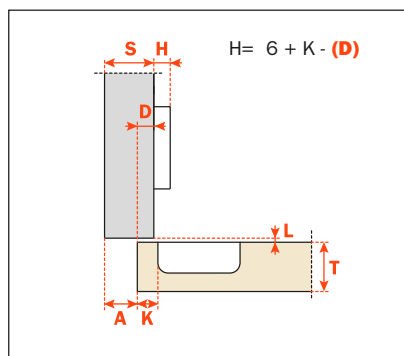
Arm 9

CA - C2_BG99
CL - C2_AG99

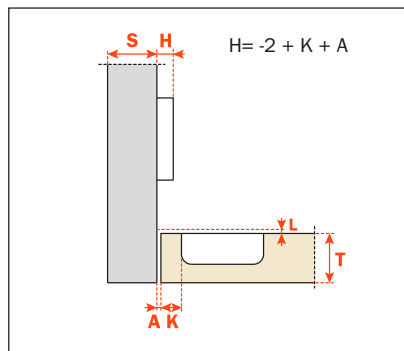
Arm 17

CA - C2_BP99
CL - C2_AP99



Technical information

When a greater opening angle is required.

11 mm deep metal cup.
 110° opening.
 Possible drilling distance on the door (K): from 3 to 6 mm.
 Compatible with all traditional Series 200 mounting plates and with all Domi snap-on mounting plates.

Space needed to open the door

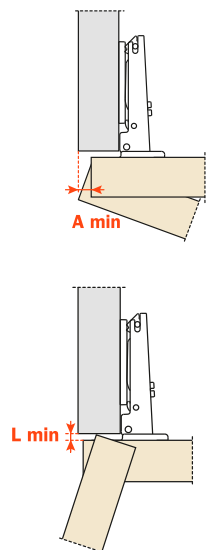

	T=	16	17	18	19	20	21	22	23	24	25	26
K=3	A=	0.5	0.7	0.9	1.2	1.5	1.8	2.4	3.7	5.1	6.5	7.8
K=4	A=	0.5	0.7	0.9	1.2	1.5	1.8	2.1	2.7	4.1	5.5	6.8
K=5	A=	0.5	0.7	0.9	1.2	1.5	1.8	2.1	2.6	3.1	4.1	5.4
K=6	A=	0.5	0.7	0.9	1.2	1.5	1.8	2.1	2.5	3.0	3.5	4.4

	T=	16	17	18	19	20	21	22	23	24	25	26
K=3	L=	0.0	0.0	0.0	0.0	0.2	0.5	0.8	1.1	1.4	1.7	1.9
K=4	L=	0.0	0.0	0.3	0.6	0.9	1.2	1.4	1.7	2.0	2.3	2.6
K=5	L=	1.1	1.3	1.6	1.8	2.1	2.3	2.6	2.9	3.1	3.4	3.6
K=6	L=	2.0	2.3	2.5	2.8	3.1	3.3	3.6	3.8	4.1	4.3	4.6

The above values are calculated on the assumption that the doors have square edges. They are reduced if the doors have radiussed edges.

Projection of the door

Projection of the door from the cabinet side at the max. opening. The figures are based on a straight arm hinge, H=0 mm thickness of mounting plate and K value = 3 mm.

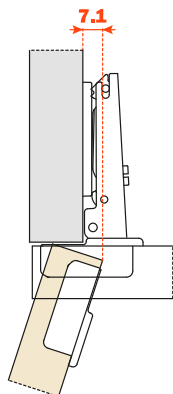

“C” value

With this formula you can obtain the max. thickness of the moulded door that can be opened without touching adjacent carcass sides, doors or walls, whilst bearing in mind the above L-K-T values.

$C = 20 + K + A$

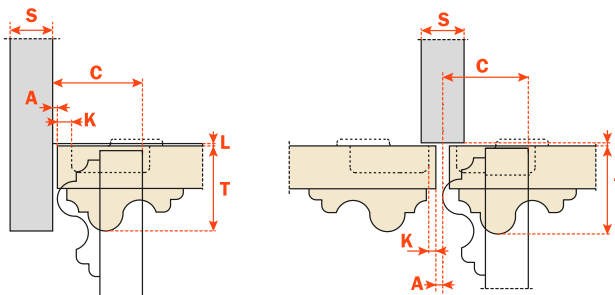

Packing

Boxes 300 pcs.
Pallets 7.200 pcs.

CA sprung hinge
CL unsprung hinge

Use these formulas to determine the type of hinge arm, the drilling distance "K" and the height of the mounting plate "H" which is necessary to solve each application problem.

Use the tables "Drillings and fixings" at page 83 to complete the code number of the desired hinge.

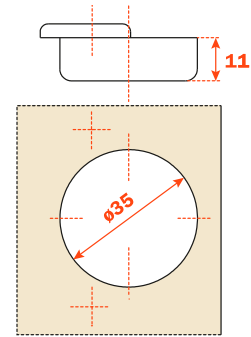
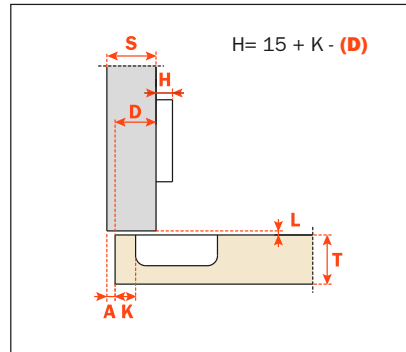
**Arm 0**

CA - C2_6A99
CL - C2_4A99

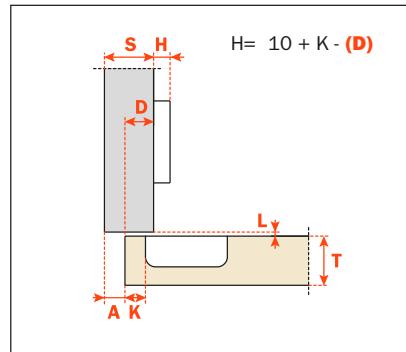
Arm 5

CA - C2_6D99
CL - C2_4D99

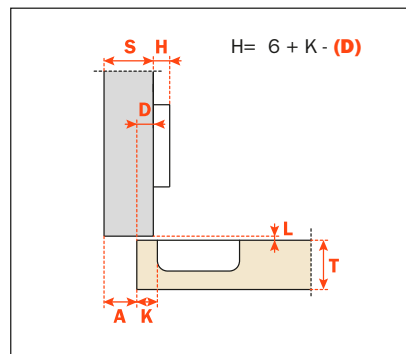
Arm 9

CA - C2_6G99
CL - C2_4G99

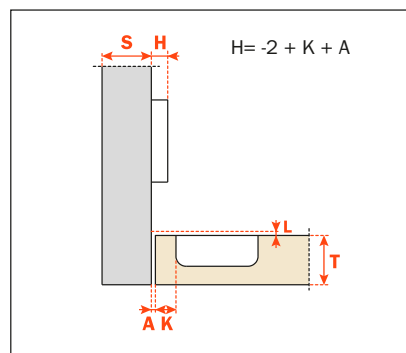
Arm 17

CA - C2_6P99
CL - C2_4P99



Technical information

When a greater opening angle is required.

11 mm deep metal cup.
 120° opening.
 Possible drilling distance on the door (K): from 3 to 6 mm.
 Compatible with all traditional Series 200 mounting plates and with all Domi snap-on mounting plates.

Space needed to open the door

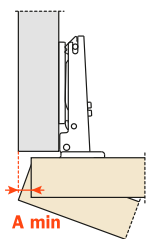

T=	16	17	18	19	20	21	22	23	24	25	26
K=3 A=	1.0	1.3	1.6	1.9	2.2	3.5	5.0	6.5	8.1	9.6	11.2
K=4 A=	1.0	1.3	1.5	1.9	2.2	2.5	4.0	5.5	7.1	8.6	10.2
K=5 A=	1.0	1.2	1.5	1.8	2.1	2.5	3.0	4.5	6.1	7.6	9.2
K=6 A=	1.0	1.2	1.5	1.8	2.1	2.4	2.8	3.5	5.1	6.6	8.1

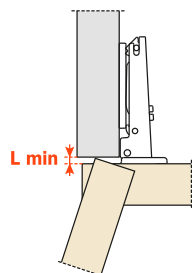

T=	16	17	18	19	20	21	22	23	24	25	26
K=3 L=	0.0	0.0	0.0	0.0	0.1	0.5	0.9	1.3	1.7	2.1	2.5
K=4 L=	0.0	0.0	0.2	0.6	1.0	1.4	1.8	2.2	2.6	3.1	3.5
K=5 L=	0.3	0.7	1.1	1.5	1.9	2.3	2.8	3.2	3.6	4.0	4.4
K=6 L=	1.2	1.6	2.0	2.4	2.8	3.3	3.7	4.1	4.5	4.9	5.3

The above values are calculated on the assumption that the doors have square edges. They are reduced if the doors have radiussed edges.

Projection of the door

Projection of the door from the cabinet side at the max. opening. The figures are based on a straight arm hinge, H=0 mm thickness of mounting plate and K value = 3 mm.

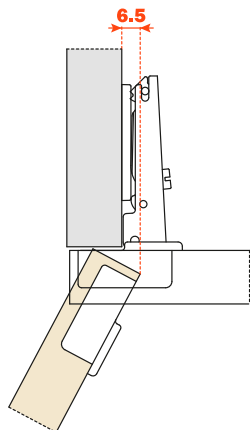

“C” value

With this formula you can obtain the max. thickness of the moulded door that can be opened without touching adjacent carcass sides, doors or walls, whilst bearing in mind the above L-K-T values.

$C = 20 + K + A$

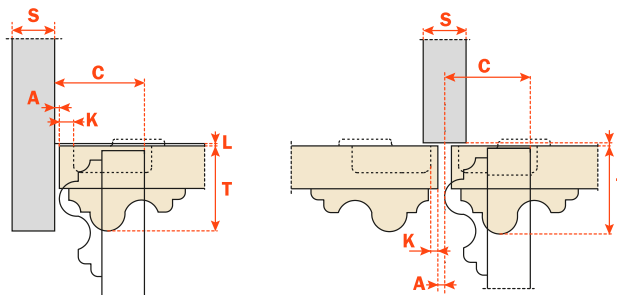

Packing

Boxes 300 pcs.
Pallets 7.200 pcs.

CA sprung hinge
CL unsprung hinge

Use these formulas to determine the type of hinge arm, the drilling distance "K" and the height of the mounting plate "H" which is necessary to solve each application problem.

Use the tables "Drillings and fixings" at page 83 to complete the code number of the desired hinge.

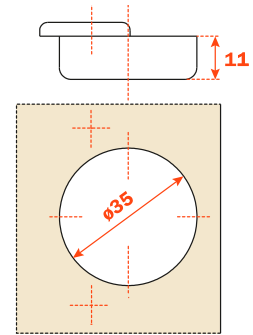
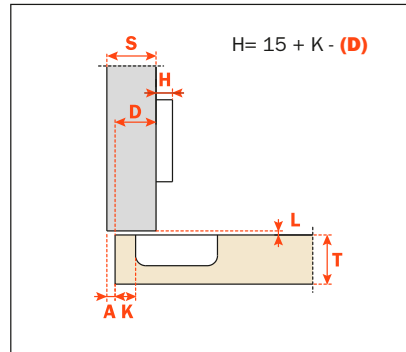
**Arm 0**

CA - C2_9A99
CL - C2_8A99

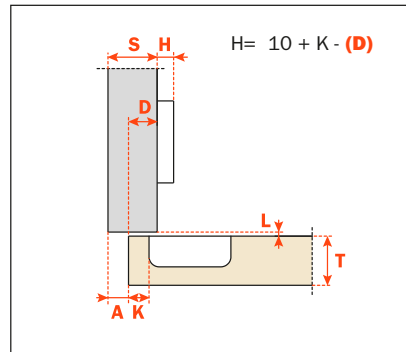
Arm 5

CA - C2_9D99
CL - C2_8D99

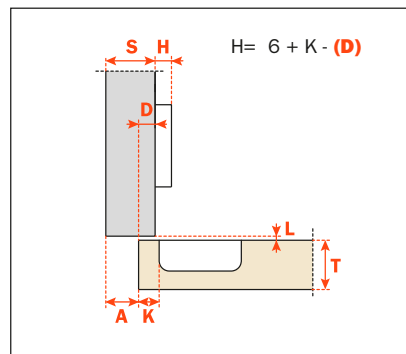
Arm 9

CA - C2_9G99
CL - C2_8G99

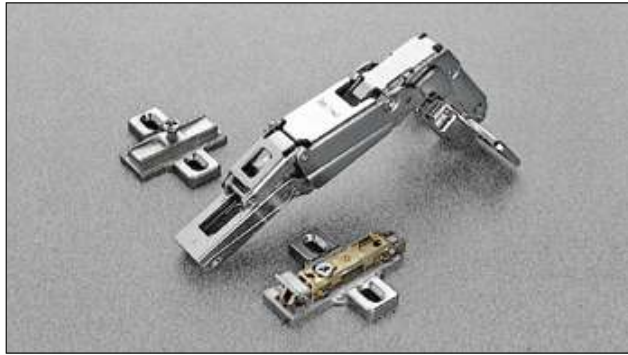

Technical information

For min.10 mm thick doors.

8 mm deep die-cast cup.

155° opening.

Possible drilling distance on the door (K) : from 3 to 8 mm.

Compatible with all traditional Series 200 mounting plates and with all Domi snap-on mounting plates.

Space needed to open the door

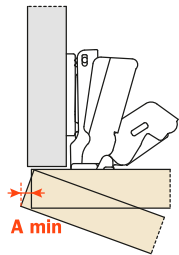

	T=	16	18	20	22
K=3	A=	0.0	0.0	0.3	1.2
K=4	A=	0.0	0.4	0.4	1.3
K=5	A=	0.0	0.1	0.5	1.6
K=6	A=	0.0	0.1	1.2	3.0
K=7	A=	0.0	0.1	0.7	2.5
K=8	A=	0.0	0.1	0.6	1.9

The above values are calculated on the assumption that the doors have square edges. They are reduced if the doors have radiussed edges.

“C” value

For spaces with removable components. The door combined with a mounting plate H=0 and a straight arm hinge opens at 90° with lateral door protrusion of 2 mm.

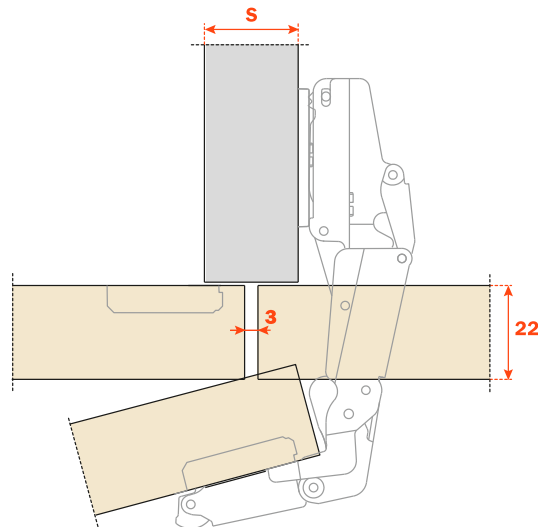
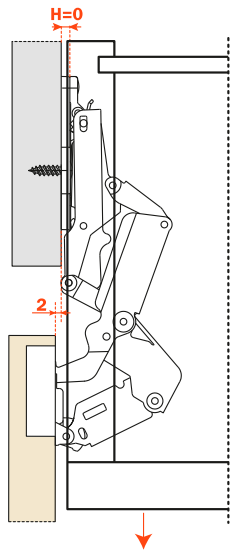

Packing

Boxes 100 pcs.
Pallets 2.400 pcs.

CA sprung hinge

Use these formulas to determine the type of hinge arm, the drilling distance "K" and the height of the mounting plate "H" which is necessary to solve each application problem.

To limit the opening of the hinge, see page 354 chapter "Accessories".

Use the tables "Drillings and fixings" at page 83 to complete the code number of the desired hinge.

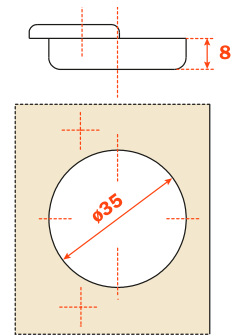
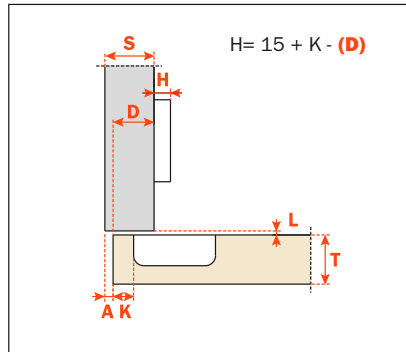
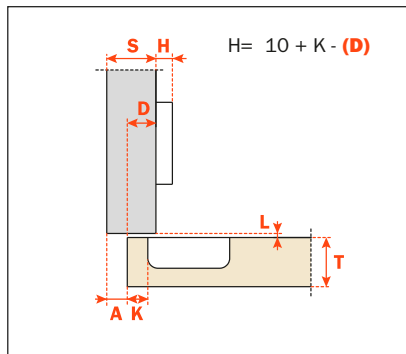
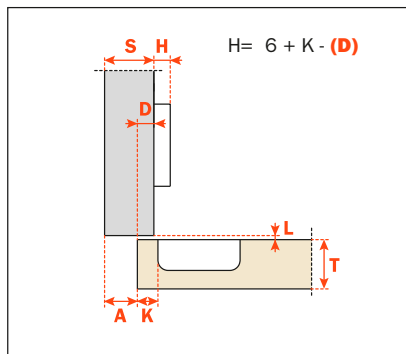
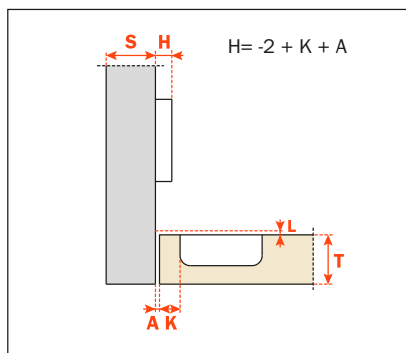
**Arm 0****CA - C2_MA99****Arm 5****CA - C2_MD99****Arm 9****CA - C2_MG99****Arm 17****CA - C2_MP99**

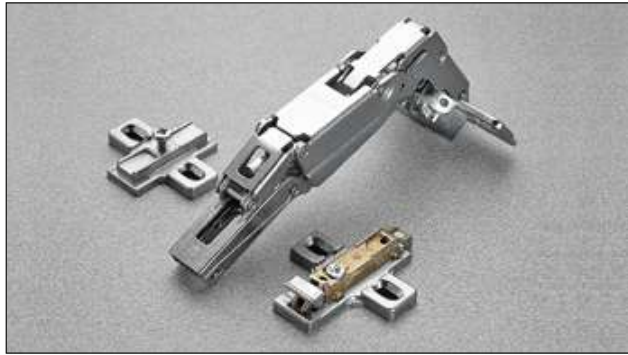

Technical information

For thicker doors max. 35 mm.
Hinge with greater opening angle and reduced operating profile.
 11 mm deep die-cast cup.
 155° opening.
 Possible drilling distance on the door (K): from 3 to 9 mm.
 Compatible with all traditional Series 200 mounting plates and with all Domi snap-on mounting plates.

Space needed to open the door

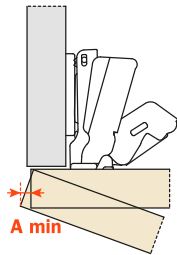

T=	26	27	28	29	30	31	32	33	34	35
K=3	A= 0.0	0.0	0.0	0.8	3.0	4.8	7.1	11.7	16.4	20.7
K=4	A= 0.0	0.0	0.0	0.8	2.5	4.0	6.2	10.6	15.0	19.7
K=5	A= 0.0	0.0	0.0	0.8	2.0	3.4	4.8	9.8	14.1	18.4
K=6	A= 0.0	0.0	0.0	0.8	1.5	2.8	4.2	8.7	13.2	17.8
K=7	A= 0.0	0.0	0.0	0.8	1.4	2.3	3.0	7.8	12.0	16.7
K=8	A= 0.0	0.0	0.0	0.2	0.9	1.9	2.7	7.0	11.2	15.7
K=9	A= 0.0	0.0	0.0	0.2	0.7	1.5	2.1	5.9	10.4	15.0

The above values are calculated on the assumption that the doors have square edges. They are reduced if the doors have radiussed edges.

“C” value

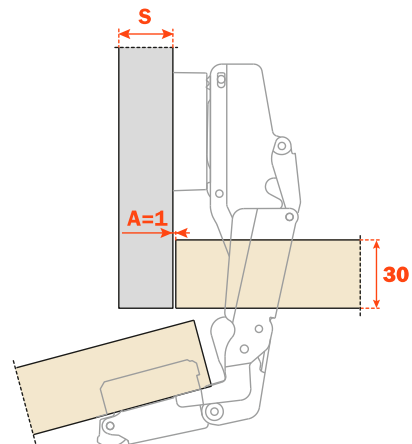
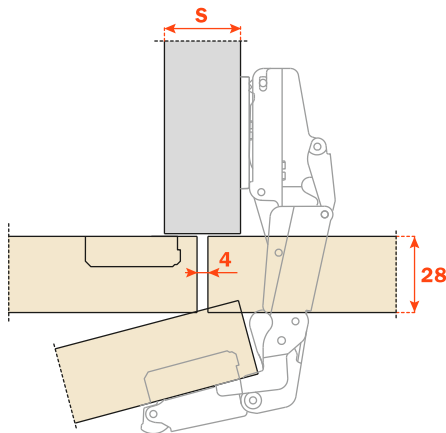

Packing

Boxes 100 pcs.
Pallets 2.400 pcs.

CA sprung hinge

Use these formulas to determine the type of hinge arm, the drilling distance "K" and the height of the mounting plate "H" which is necessary to solve each application problem.

To limit the opening of the hinge, see page 354 chapter "Accessories".

Use the tables "Drillings and fixings" at page 83 to complete the code number of the desired hinge.

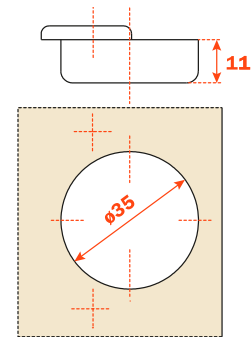

Arm 0

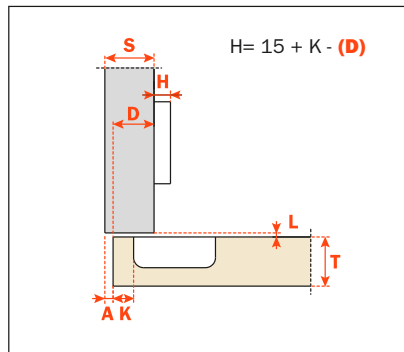
**CA - C2_DA99**

Arm 5

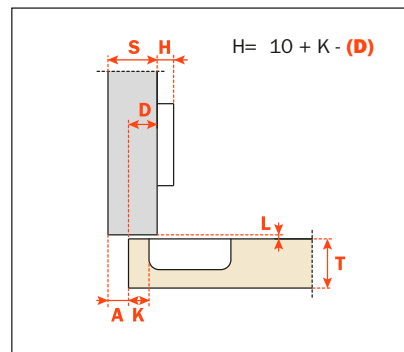
**CA - C2_DD99**

Arm 9

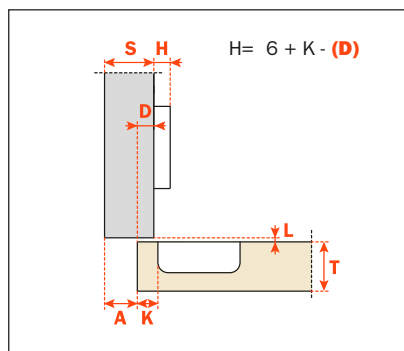
**CA - C2_DG99**

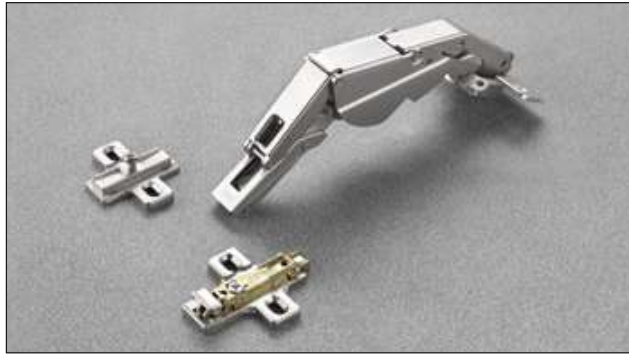

Technical information

For thicker doors max. 35 mm.
Hinge with greater opening angle and reduced operating profile.
 11 mm deep die-cast cup.
 155° opening.
 Possible drilling distance on the door (K): from 3 to 9 mm.
 Compatible with all traditional Series 200 mounting plates and with all Domi snap-on mounting plates.

Space needed to open the door

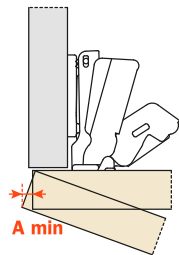

T=	27	28	29	30	31	32	33	34	35	36
K=3	A= 0.0	0.0	0.2	0.6	0.8	1.0	1.4	1.9	2.3	3.0
K=4	A= 0.0	0.0	0.2	0.6	0.8	1.0	1.4	1.9	2.3	3.0
K=5	A= 0.0	0.0	0.2	0.6	0.8	1.1	1.5	1.9	2.5	3.2
K=6	A= 0.0	0.0	0.2	0.6	0.8	1.2	1.6	1.9	2.5	3.8
K=7	A= 0.0	0.0	0.2	0.6	0.8	1.3	1.7	2.1	2.7	3.9
K=8	A= 0.0	0.0	0.2	0.6	0.8	1.4	1.7	2.1	2.7	4.0
K=9	A= 0.0	0.0	0.2	0.6	0.8	1.4	1.7	2.1	3.0	4.0

The above values are calculated on the assumption that the doors have square edges. They are reduced if the doors have radiussed edges.

“C” value

For spaces with removable components. The door combined with a mounting plate H=0 opens at 90° with lateral door protrusion of 3.5 mm.

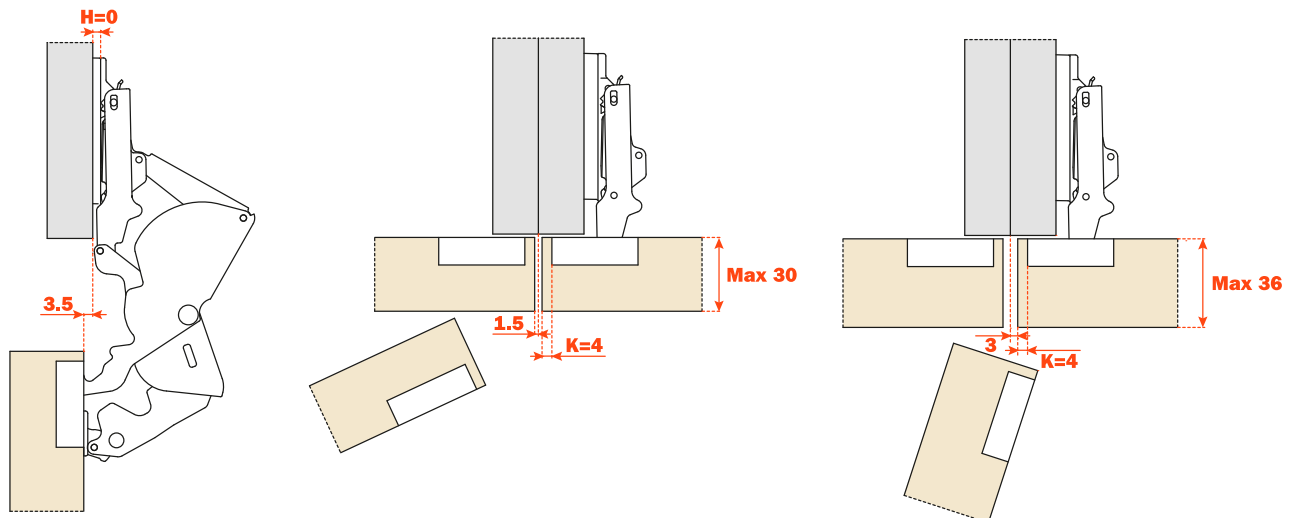

With stop device 110°

Packing

Boxes 100 pcs.
 Pallets 2.400 pcs.

CA sprung hinge

Use these formulas to determine the type of hinge arm, the drilling distance "K" and the height of the mounting plate "H" which is necessary to solve each application problem.

To limit the opening of the hinge, see page 354 chapter "Accessories".

Use the tables "Drillings and fixings" at page 83 to complete the code number of the desired hinge.

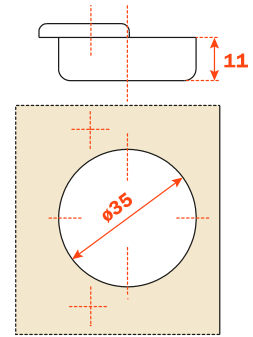

Arm **0**

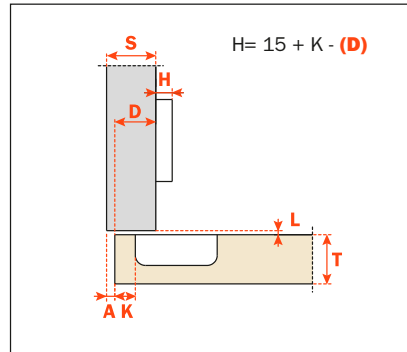
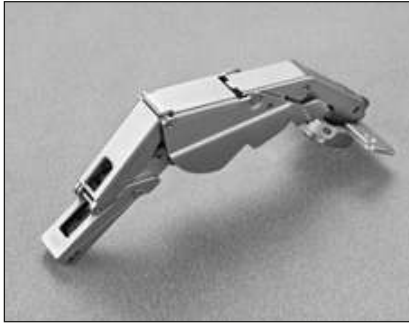

CA - C2_HA99



Technical information

Hinge with greater opening angle and reduced operating profile.

11 mm deep die-cast cup.

165° opening.

Possible drilling distance on the door (K): from 3 to 8 mm.

Compatible with all traditional Series 200 mounting plates and with all Domi snap-on mounting plates.

Space needed to open the door

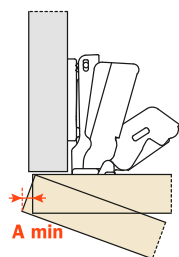

	T=	16	18	20	22	24	26	28
K=3	A=	0.0	0.0	0.0	0.7	2.7	4.6	7.9
K=4	A=	0.0	0.0	0.0	0.1	1.8	3.8	6.9
K=5	A=	0.0	0.0	0.0	0.1	1.2	3.0	5.9
K=6	A=	0.0	0.0	0.0	0.1	0.9	2.5	4.9
K=7	A=	0.0	0.0	0.0	0.1	0.7	2.0	3.9
K=8	A=	0.0	0.0	0.0	0.1	0.6	1.7	3.2

The above values are calculated on the assumption that the doors have square edges. They are reduced if the doors have radiussed edges.

"C" value

For spaces with removable components. Opening with lateral door protrusion equal to 5.5 mm with a hinge with straight arm, H=0 mounting plate and K=3 mm.

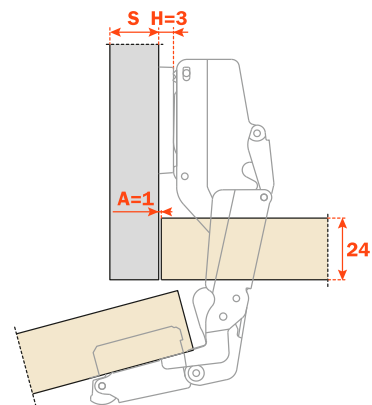
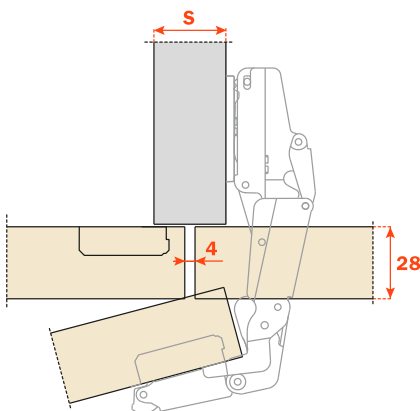
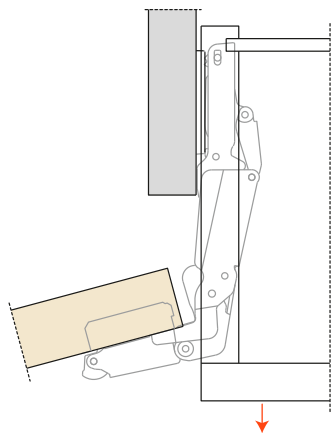

Packing

Boxes 100 pcs.
Pallets 2.400 pcs.

CA sprung hinge
CL unsprung hinge

Use these formulas to determine the type of hinge arm, the drilling distance "K" and the height of the mounting plate "H" which is necessary to solve each application problem.

To limit the opening of the hinge, see page 354 chapter "Accessories".

Use the tables "Drillings and fixings" at page 83 to complete the code number of the desired hinge.

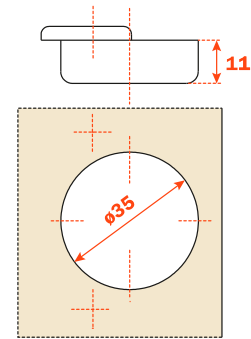
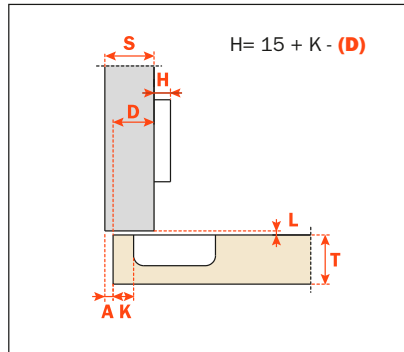
**Arm 0**

CA - C2_FA99
CL - C2_EA99

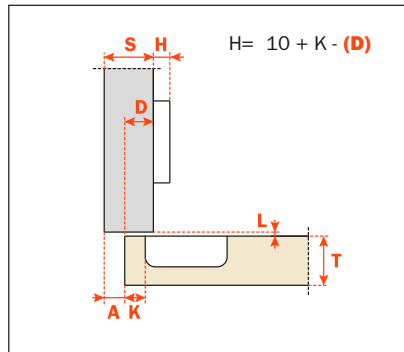
Arm 5

CA - C2_FD99
CL - C2_ED99

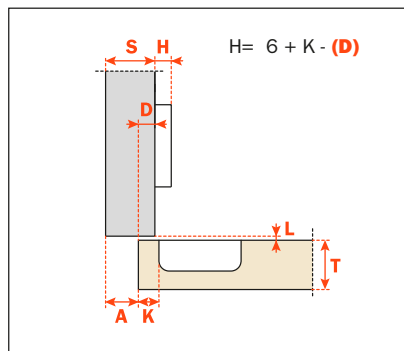
Arm 9

CA - C2_FG99
CL - C2_EG99

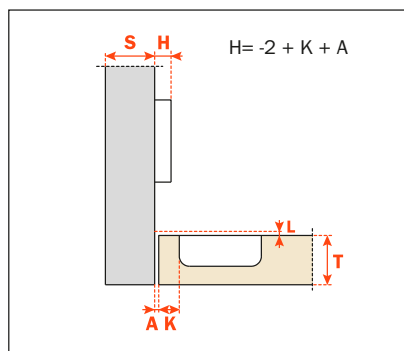
Arm 17

CA - C2_FP99
CL - C2_EP99



Technical information

Hinges for glass doors.

Hole diameter 26 mm.

94° opening.

For use with glass from 4 mm to 6 mm thickness.

Possible drilling distance on the door (K): from 5.5 to 6.5 mm.

Compatible with all traditional Series 200 mounting plates and with all Domi snap-on mounting plates.

P2CTA

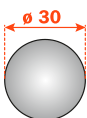

Fancy covers

See page 352 chapter "Accessories" for the available finishes.

P2CBA

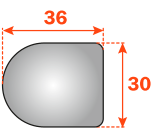

P2CQA

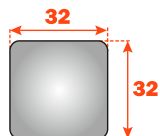

Packing

Boxes 150 pcs.
Pallets 3.600 pcs.

Use these formulas to determine the type of hinge arm, the drilling distance "K" and the height of the mounting plate "H" which is necessary to solve each application problem.

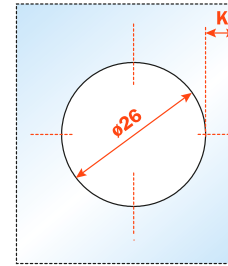
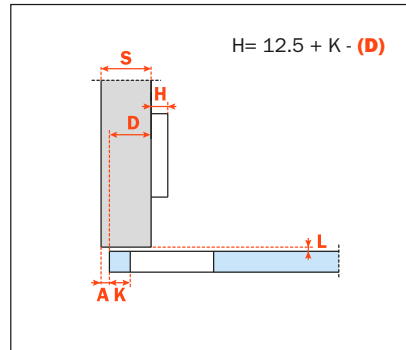
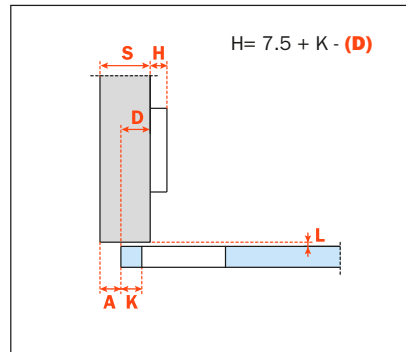
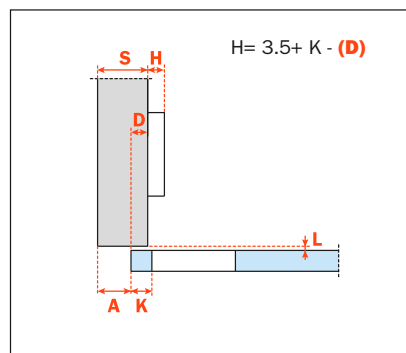
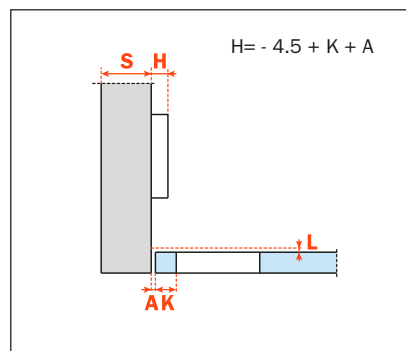
**Arm 0****CA - C2C7A39****Arm 5****CA - C2C7D39****Arm 9****CA - C2C7G39****Arm 17****CA - C2C7P39**

Packing

Boxes 150 pcs.
Pallets 3.600 pcs.

CA sprung hinge

The solution of assembly problems where doors are mounted at a positive or negative angle requires the verification of drilling distances by a practical trial. Please do not hesitate to consult our technical support department for assistance.

Technical information

Hinges for glass doors with positive angled assembly.

Hole diameter 26 mm.

94° opening.

For use with glass from 4 mm to 6 mm thickness.

Possible drilling distance on the door (K): from 5.5 to 6.5 mm.

Compatible with all Series 200 traditional mounting plates and with all Domi snap-on mounting plates.

Applications with doors set at any angle between - 7.5° to + 70° are possible by combining the appropriate hinge and mounting plate.

Arm 30°

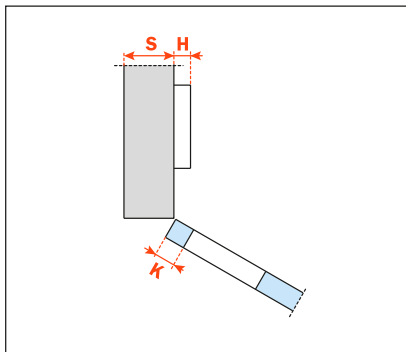

CA - C2C7E39

Arm 45°

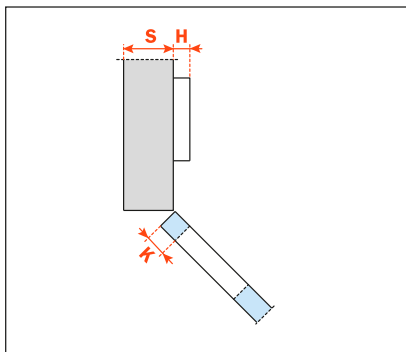

CA - C2C7M39

Crampon

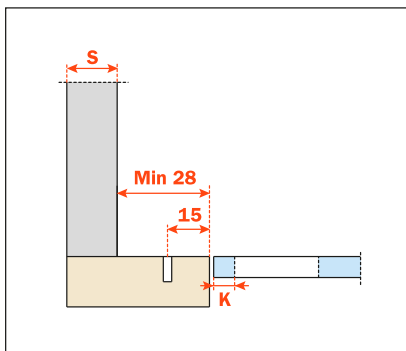

Crampon hinges. To be used only with Series 200 mounting plates for traditional assembly and drilling 28x32 mm.

CA - C2C7N39

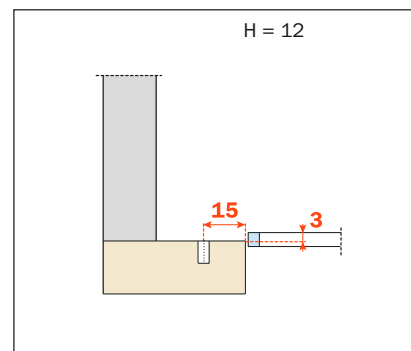
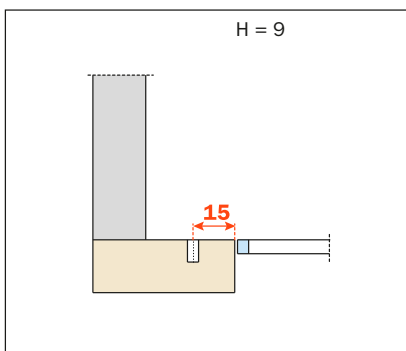
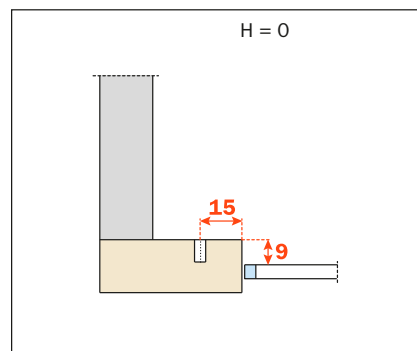

Complementary hinges



Technical information

Hinges for fridge doors.

11 mm deep metal cup.

94° opening.

Possible drilling distance on the door (K): from 3 to 9 mm.

Compatible with all traditional Series 200 mounting plates.

NOT COMPATIBLE with Domi snap-on mounting plates.

Packing

Boxes 150 pcs.

Pallets 3.600 pcs.

Use the tables "Drillings and fixings" at page 83 to complete the code number of the desired hinge.

CA sprung hinge

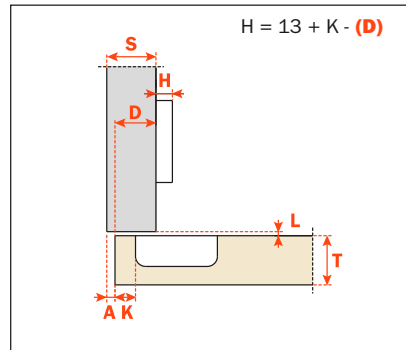
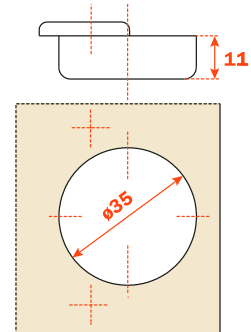

CA - C2_BF99

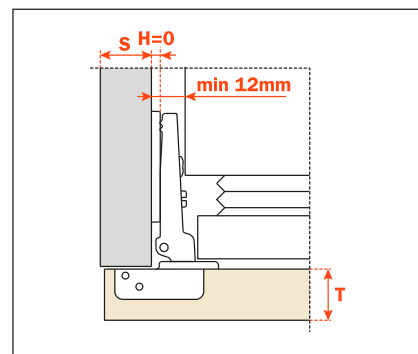
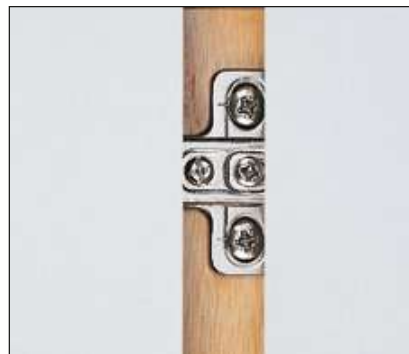



Technical information

Hinges for wooden doors with positive angled assembly.
 11 mm deep metal cup.
 94° opening.
 Possible drilling distance on the door (K): from 3 to 9 mm.
 Compatible with all traditional Series 200 mounting plates and with all Domi snap-on mounting plates.

Packing

Boxes 150 pcs.
 Pallets 3.600 pcs.

CA sprung hinge

The solution of assembly problems where doors are mounted at a positive or negative angle requires the verification of drilling distances by a practical trial. Please do not hesitate to consult our technical support department for assistance.

Use the tables "Drillings and fixings" at page 83 to complete the code number of the desired hinge.

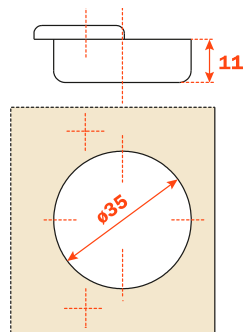

Arm **15°**

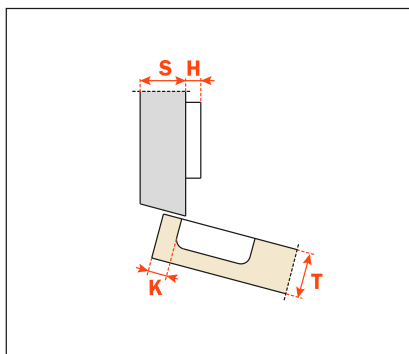

CA - C2_BZ99

Arm **24°**

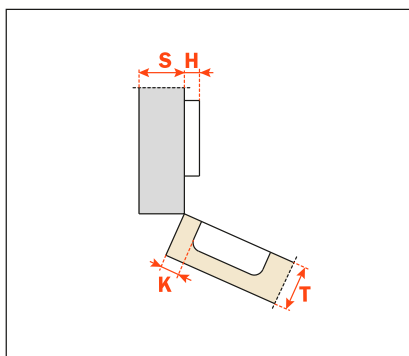

CA - C2_BU99

Arm **30°**

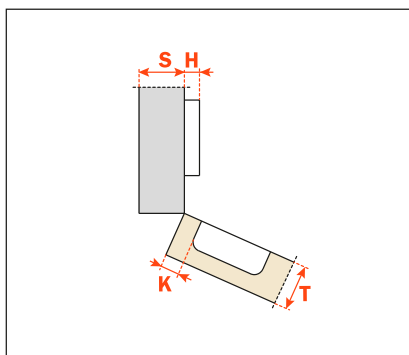

CA - C2_BE99

Arm 30°

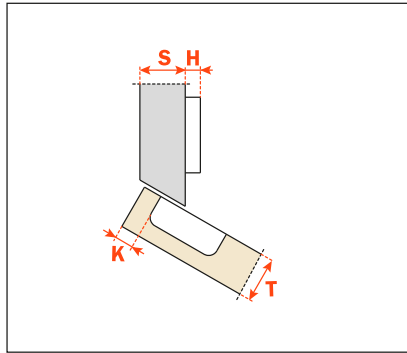

CA - C2_BT99

Arm 37°

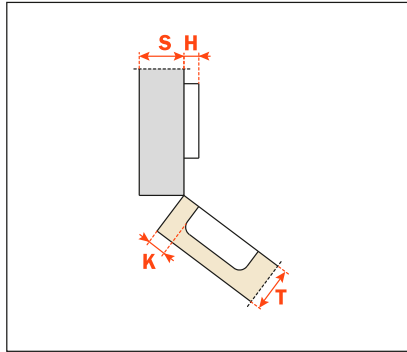

CA - C2_BK99

Arm 45°

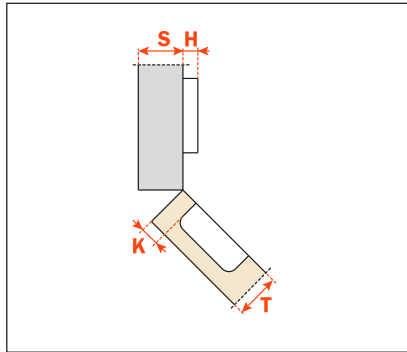

CA - C2_BM99

Arm 45°

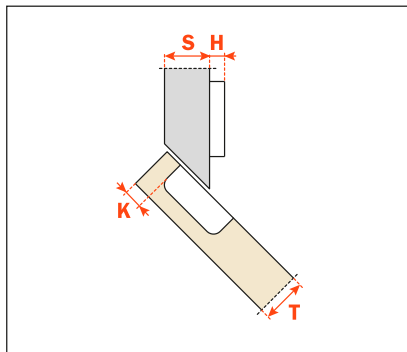

CA - C2_BV99

Arm 45°

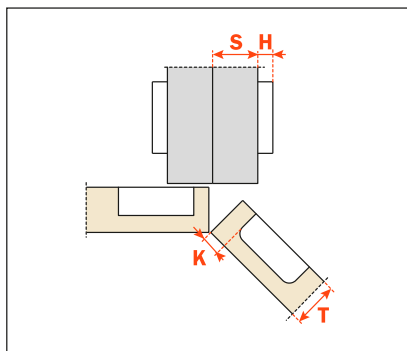

CA - C2_BM99AC



Technical information

Hinges for wooden doors with negative angled assembly.

11 mm deep metal cup.
 120° opening.
 Possible drilling distance on the door (K): from 3 to 6 mm.
 Compatible with all traditional Series 200 mounting plates and with all Domi snap-on mounting plates.

Packing

Boxes 150 pcs.
 Pallets 3.600 pcs.

CA sprung hinge

The solution of assembly problems where doors are mounted at a negative angle requires the verification of drilling distances by a practical trial. Please do not hesitate to consult our technical support department for assistance.

Use the tables "Drillings and fixings" at page 83 to complete the code number of the desired hinge.

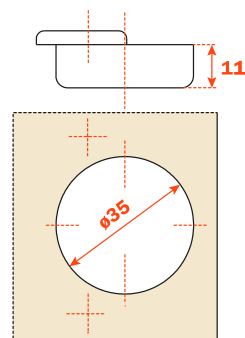

Arm **-30°**

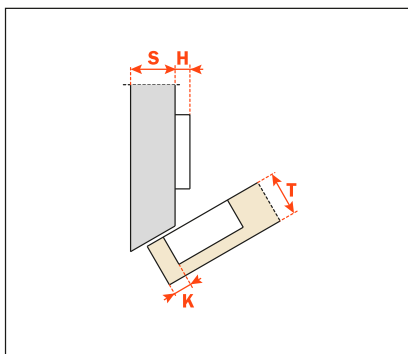

CA - C2_BW99

Arm **-45°**

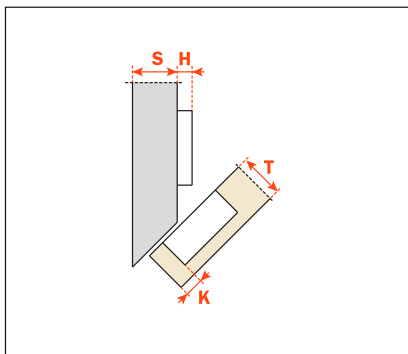

CA - C2_BH99



Technical information

Crampon hinges.

For cabinet sides with 37x32 mm standard drilling.

11 mm deep metal cup.

94° opening.

Possible drilling distance on the door (K): from 3 to 9 mm.

Compatible with all traditional Series 200 mounting plates and with all Domi snap-on mounting plates.

Packing

Boxes 150 pcs.

Pallets 3.600 pcs.

CA sprung hinge

E min:

61 mm for Series 200 mounting plates.

70 mm for Domi snap-on mounting plates.

74 mm for Domi snap-on mounting plates with back cam.

Use the tables "Drillings and fixings" at page 83 to complete the code number of the desired hinge.

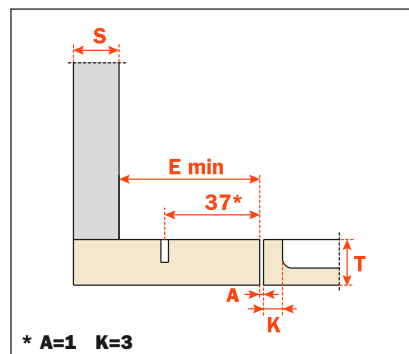
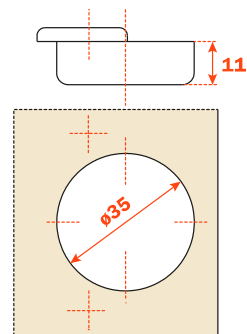

* A=1 K=3

CA - C2_BN99AC

Heights of mounting plates for every assembly.

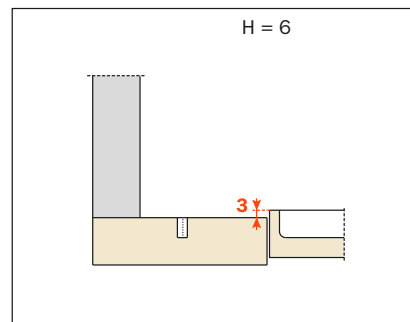
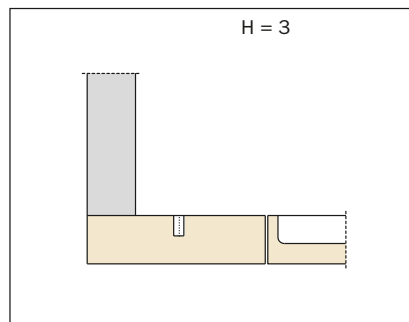
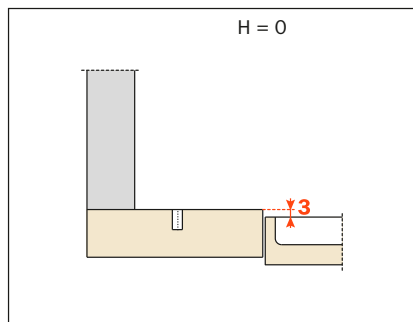



Technical information

Crampon hinges.

For smaller spaces with 15x32 mm drilling.

11 mm deep metal cup.

94° opening.

Possible drilling distance on the door (K): from 3 to 9 mm.

Compatible with all traditional Series 200 mounting plates, 28x32 mm drilling.

NOT COMPATIBLE with Domi snap-on mounting plates.

Packing

Boxes 150 pcs.

Pallets 3.600 pcs.

Use the tables "Drillings and fixings" at page 83 to complete the code number of the desired hinge.

CA sprung hinge

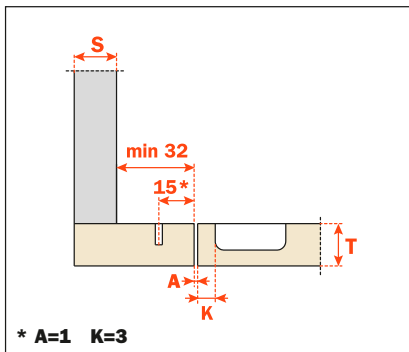
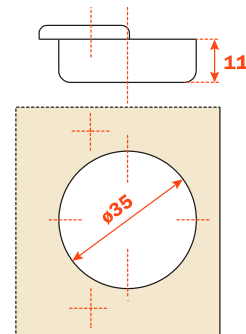

CA - C2_BN99

Heights of mounting plates for every assembly.

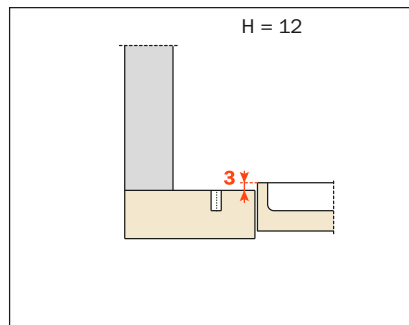
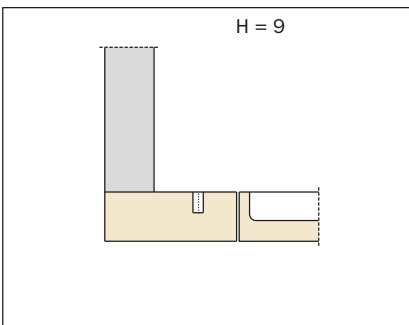
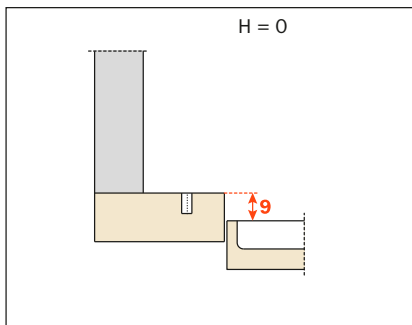



Technical information

Long crampon hinges.

11 mm deep metal cup.

110° opening.

Possible drilling distance on the door (K): from 3 to 6 mm.

Compatible with all traditional Series 200 mounting plates and with all Domi snap-on mounting plates.

Packing

Boxes 150 pcs.

Pallets 3.600 pcs.

CA sprung hinge

E min:

61 mm for Series 200 mounting plates.

70 mm for Domi snap-on mounting plates.

74 mm for Domi snap-on mounting plates with back cam.

Use the tables "Drillings and fixings" at page 83 to complete the code number of the desired hinge.

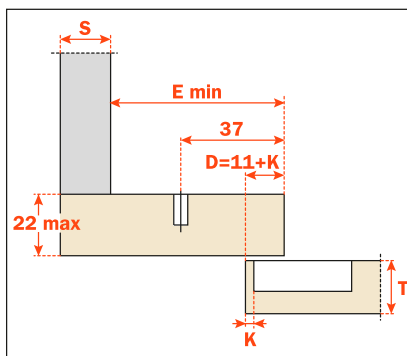
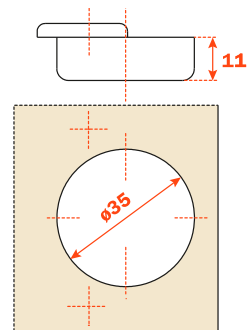

CA - C2_6N99AM

Heights of mounting plates for every assembly.

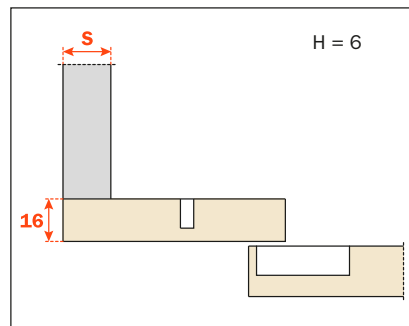
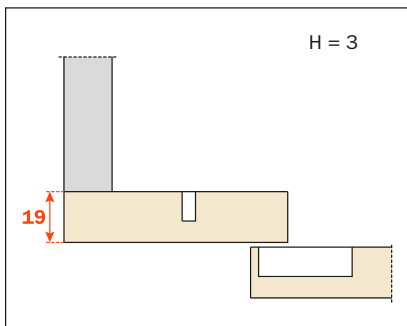
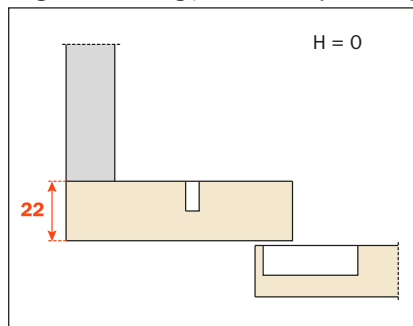



Technical information

Hinges for corner cabinets.

11 mm deep die-cast cup.
 35 mm cup diameter.
 Opening angle of the first door 70°.
 Possible drilling distance on the door (K) : from 3 to 6 mm.

Maximum thickness of the door with square edges: 23 mm.
 For thicker doors or doors with mouldings or with large radiused edges, please refer to our technical assistance.
 Compatible with all traditional Series 200 mounting plates and with all Domi snap-on mounting plates.

Packing

Boxes 150 pcs.
 Pallets 3.600 pcs.

Use the tables "Drillings and fixings" at page 83 to complete the code number of the desired hinge.

CA sprung hinge

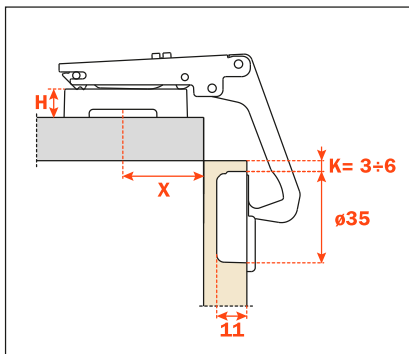
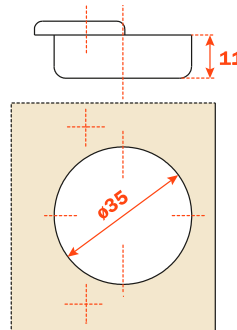

CA - C2_YA99

Use these formulas to determine the height of mounting plate and drilling distance

Drilling distance:
 cruciform mounting plates = $47 - T$

Drilling distance:
 longitudinal mounting plates = $(31 - T) + 32$

$H^* = 26 - T - K$
 The mounting plate heights that are not standard are obtained with the mounting plate of lower height + sideways adjustment

T = Thickness of the door with square edges

Examples with doors with square edges

T	K	X	X	H
20	5	$47 - 20 = 27$ mm	$31 - 20 = 11 + 32$ mm	$26 - 20 - 5 = 1$ mm
16	6	$47 - 16 = 31$ mm	$31 - 16 = 15 + 32$ mm	$26 - 16 - 6 = 4$ mm
19	3	$47 - 19 = 28$ mm	$31 - 19 = 12 + 32$ mm	$26 - 19 - 3 = 4$ mm
18	4	$47 - 18 = 29$ mm	$31 - 18 = 13 + 32$ mm	$26 - 18 - 4 = 5$ (H = 4 + 1 mm adjustment)

C2AYA99 hinge movement and maximum opening width

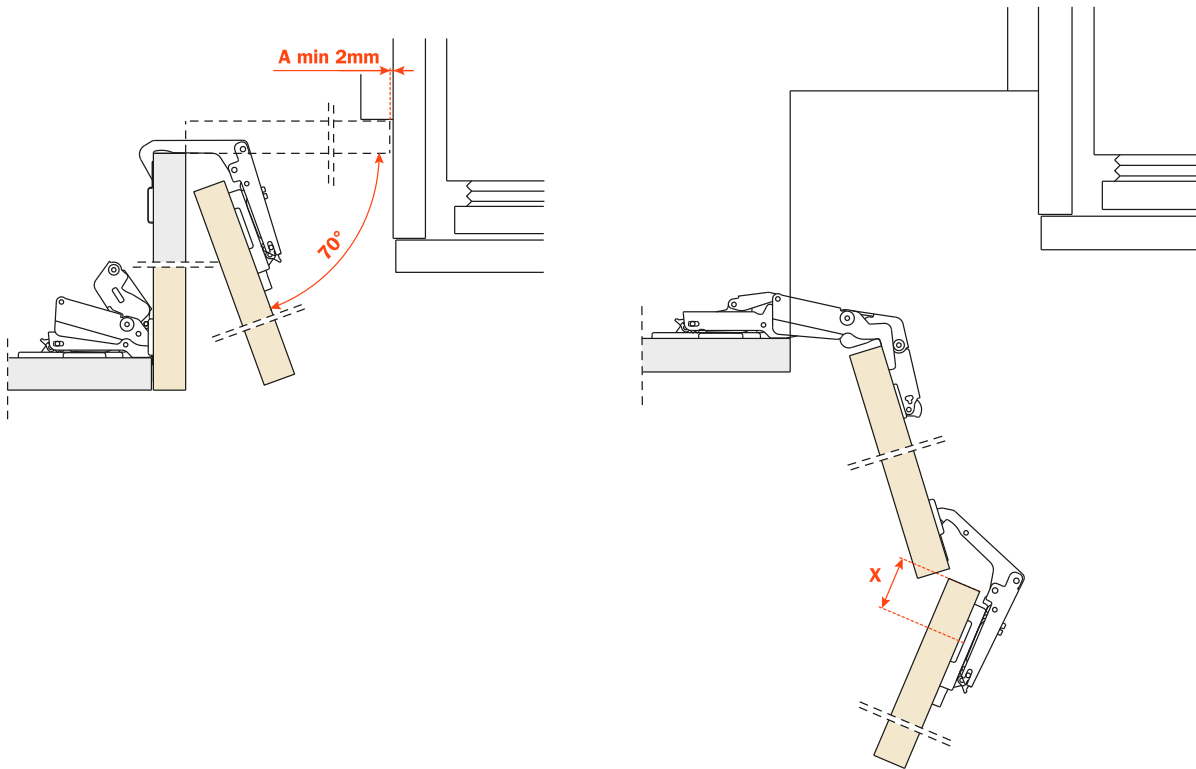

Space required to accommodate the hinge

With Series 200 mounting plates

The maximum space required to accommodate the hinge is 52 mm with 16 mm thick doors. With thicker doors the amount of space required is reduced.

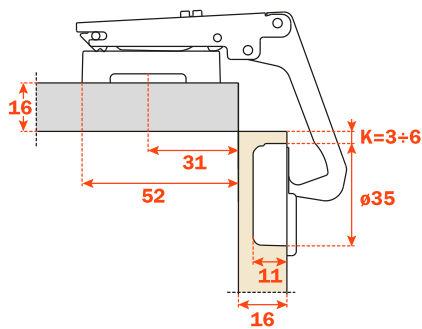

With Domi snap-on mounting plates

The maximum space required to accommodate the hinge with 16 mm thick doors is 64 mm with Domi mounting plates and 68 mm with mounting plates with back cam. With thicker doors the amount of space required is reduced.

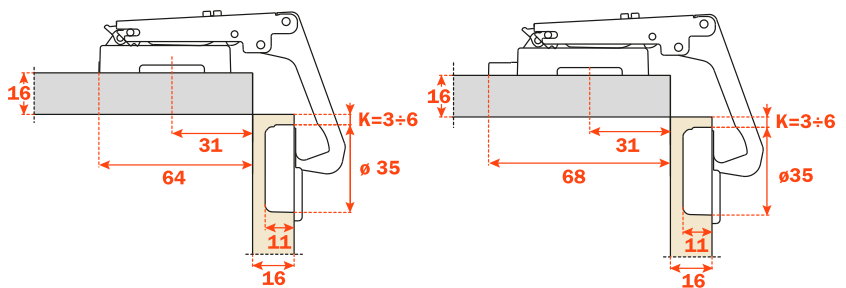

Series 200 - Complementary hinges - Special angled assemblies

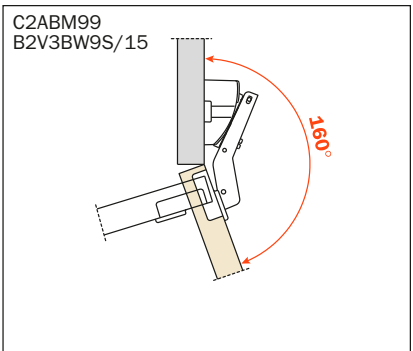
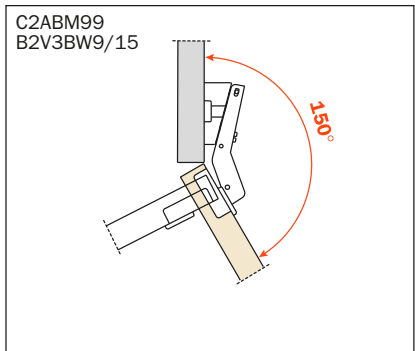
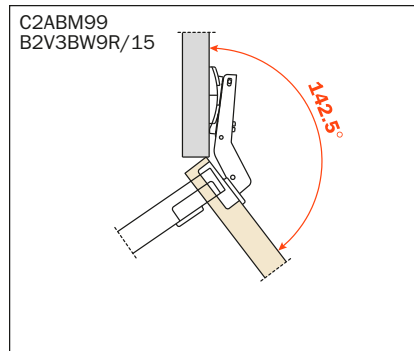
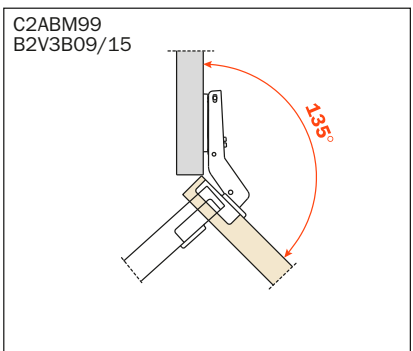
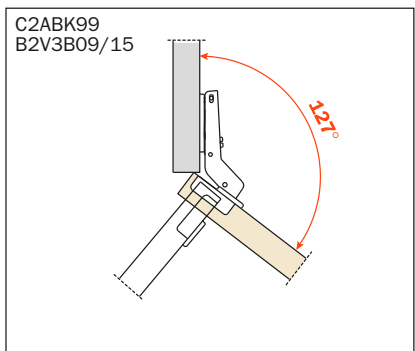
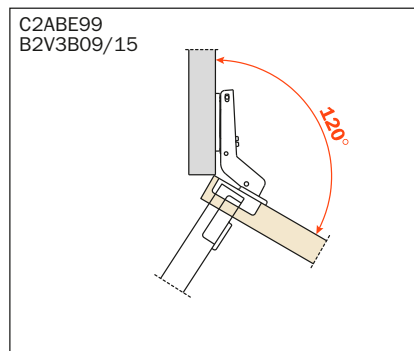
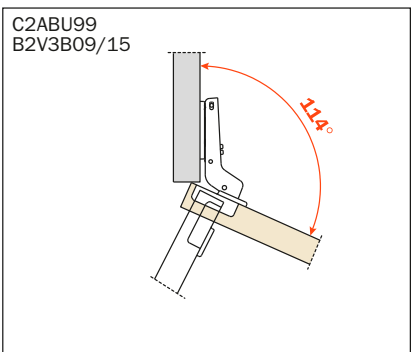
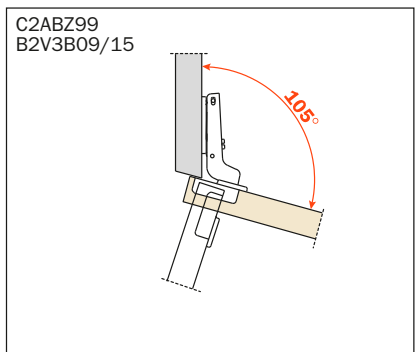
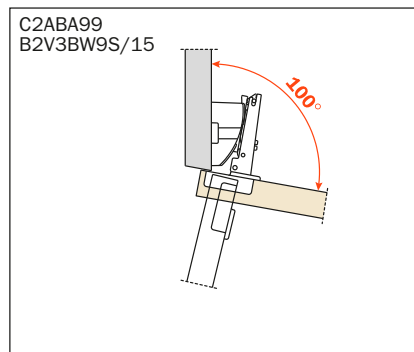
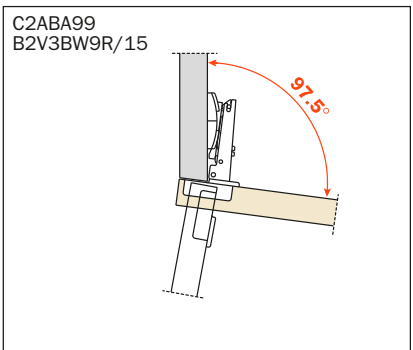
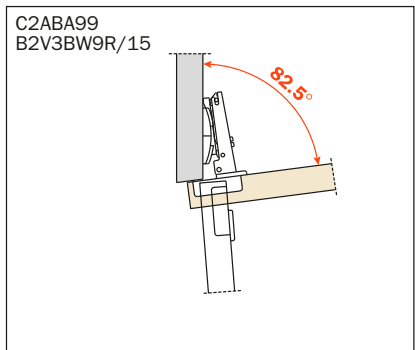
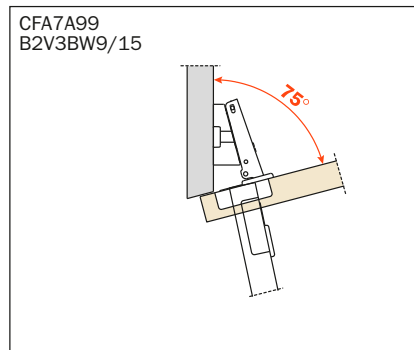
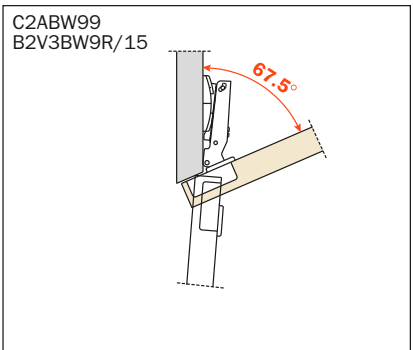
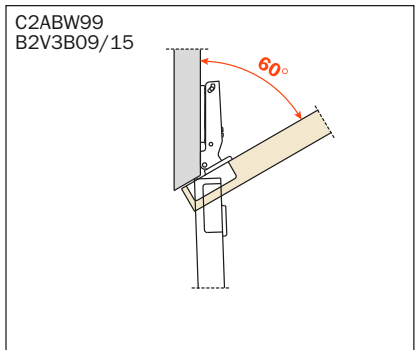
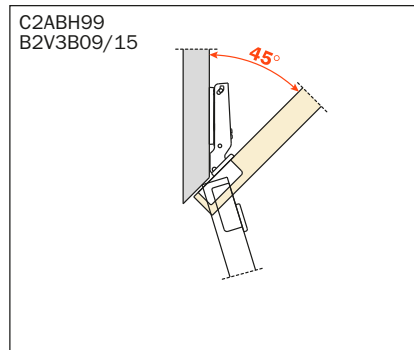

Series F



Series F

**Bright nickel plated steel cup and die-cast arm.
Dimensions of the Ø 40 mm cup.**

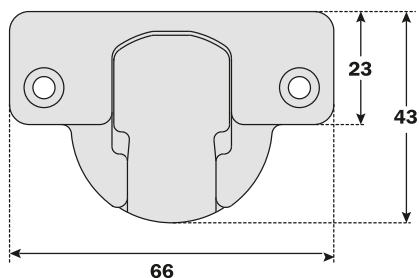

Constant "L" value of 0.7 mm (it does not change during side adjustment).

Approx. number of hinges required according to the door dimension and weight.

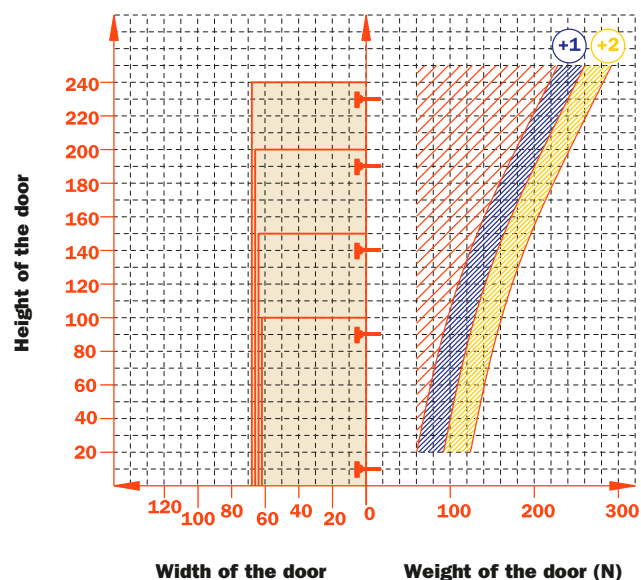

Adjustments

Compensated side adjustment from -0.5 mm to +5.5 mm.
Height adjustment ±2 mm.
Depth adjustment with Series 200 mounting plates +2.8 mm.
Depth adjustment with Domi mounting plates from -0.5 mm to +2.8 mm.

Mounting plates

Symmetrical and asymmetrical bright nickel plated steel or die-cast Series 200 mounting plates.
Snap-on assembly on Domi mounting plates.
Positioning with pre-determined stop on traditional Series 200 mounting plates.

N.B. : Use POZIDRIVE No. 2 screwdrivers for all screws.

<p>Wood screw</p>	<p>A</p>

<p>Dowel</p>	<p>B</p>

**Use this table to identify the available drillings and fixings.
 Fill the third position of the hinge code number with the letter or the number
 corresponding to your choice. I.e.: CF_7A99.**

↑
 Fill this position with the chosen letter or number.



Technical information

For profile and thicker doors (max. 40 mm).

13 mm deep steel cup.
 40 mm cup diameter.
 94° opening.
 Possible drilling distance on the door (K): from 3 to 15 mm.
 Compatible with all traditional Series 200 mounting plates and with all Domi snap-on mounting plates.

Space needed to open the door

	T=	20	21	22	23	24	25	26	27	28	29	30	31	32	33	34	35	36	37	38	39	40	L=
K=3	A=	0.4	0.5	0.7	0.8	1.0	1.2	1.4	1.6	1.9	2.2	2.5	2.8	3.1	3.5	4.1	5.0	6.0	6.9	7.8	8.8	9.7	0.0
K=4	A=	0.4	0.5	0.7	0.8	1.0	1.2	1.4	1.6	1.9	2.1	2.4	2.7	3.0	3.4	3.8	4.4	5.3	6.3	7.2	8.1	9.0	0.0
K=5	A=	0.4	0.5	0.6	0.8	1.0	1.2	1.4	1.6	1.8	2.1	2.4	2.7	3.0	3.3	3.7	4.1	4.8	5.7	6.6	7.5	8.4	0.0
K=6	A=	0.4	0.5	0.6	0.8	0.9	1.1	1.3	1.6	1.8	2.1	2.3	2.6	2.9	3.3	3.6	4.0	4.4	5.2	6.0	6.9	7.8	0.0
K=7	A=	0.4	0.5	0.6	0.8	0.9	1.1	1.3	1.5	1.8	2.0	2.3	2.6	2.9	3.2	3.6	3.9	4.3	4.8	5.5	6.4	7.3	0.0
K=8	A=	0.4	0.5	0.6	0.8	0.9	1.1	1.3	1.5	1.7	2.0	2.2	2.5	2.8	3.1	3.5	3.8	4.2	4.7	5.1	5.9	6.8	0.0
K=9	A=	0.4	0.5	0.6	0.7	0.9	1.1	1.3	1.5	1.7	2.0	2.2	2.5	2.8	3.1	3.4	3.8	4.2	4.6	5.0	5.5	6.3	0.0
K=10	A=	0.3	0.5	0.6	0.7	0.9	1.1	1.3	1.5	1.7	1.9	2.2	2.4	2.7	3.0	3.4	3.7	4.1	4.5	4.9	5.4	6.0	0.0
K=11	A=	0.3	0.4	0.6	0.7	0.9	1.0	1.2	1.4	1.7	1.9	2.1	2.4	2.7	3.0	3.3	3.6	4.0	4.4	4.8	5.2	5.7	0.0
K=12	A=	0.3	0.4	0.6	0.7	0.9	1.0	1.2	1.4	1.6	1.9	2.1	2.4	2.6	2.9	3.3	3.6	3.9	4.3	4.7	5.1	5.6	0.4
K=13	A=	0.3	0.4	0.5	0.7	0.9	1.0	1.2	1.4	1.6	1.8	2.1	2.3	2.6	2.9	3.2	3.5	3.8	4.2	4.5	4.9	5.4	1.2
K=14	A=	0.3	0.4	0.5	0.7	0.8	1.0	1.2	1.4	1.6	1.8	2.0	2.3	2.6	2.8	3.2	3.5	3.8	4.2	4.5	4.9	5.4	2.2
K=15	A=	0.3	0.4	0.5	0.7	0.8	1.0	1.2	1.4	1.6	1.8	2.0	2.3	2.6	2.8	3.2	3.5	3.8	4.2	4.5	4.9	5.4	3.2

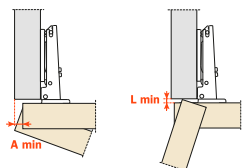

The above values are calculated on the assumption that the doors have square edges. They are reduced if the doors have radiused edges.

Projection of the door

Projection of the door from the cabinet side at the max. opening. The figures are based on a straight arm hinge, H=0 mm thickness of mounting plate and K value = 3 mm.

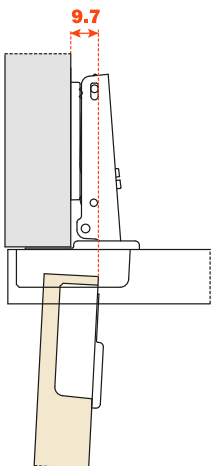

“C” value

With this formula you can obtain the max. thickness of the moulded door that can be opened without touching adjacent carcass sides, doors or walls, whilst bearing in mind the above L-K-T values.

$$C = 28.5 + K + A$$

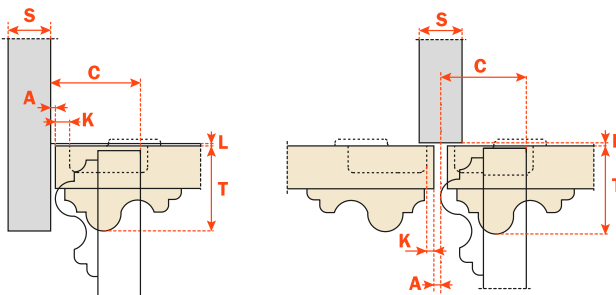

Packing

Boxes 300 pcs.
Pallets 7.200 pcs.

CA sprung hinge
CL unsprung hinge

Use these formulas to determine the type of hinge arm, the drilling distance "K" and the height of the mounting plate "H" which is necessary to solve each application problem.

Use the tables "Drillings and fixings" at page 113 to complete the code number of the desired hinge.

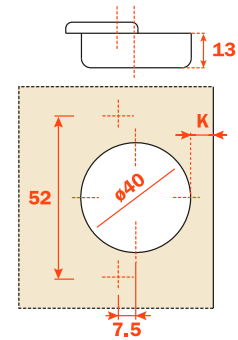

Arm 0

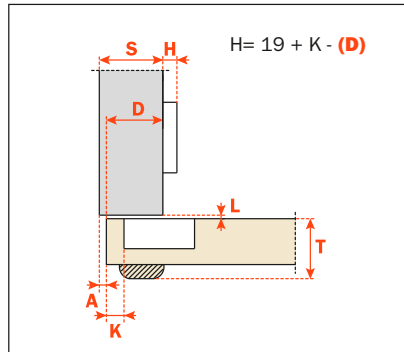

CA - CF_7A99
CL - CF_5A99

Arm 11

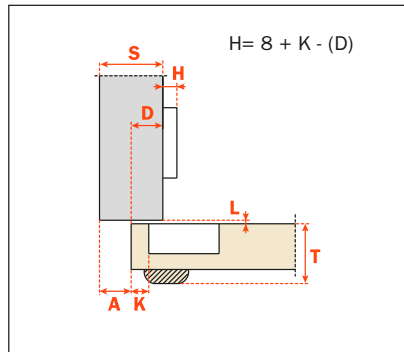

CA - CF_7G99
CL - CF_5G99

Arm 22

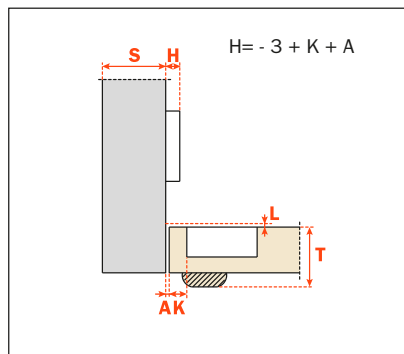

CA - CF_7P99
CL - CF_5P99

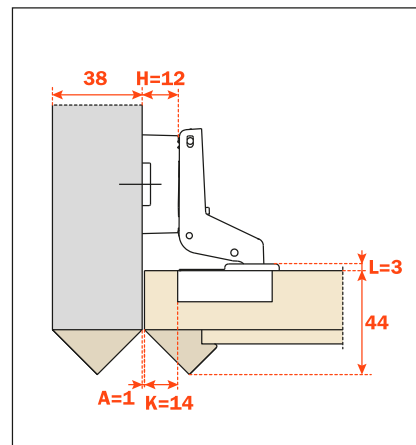
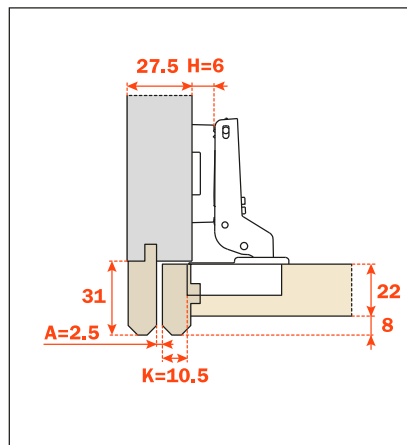
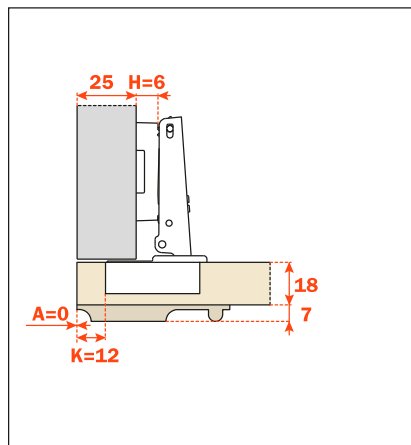
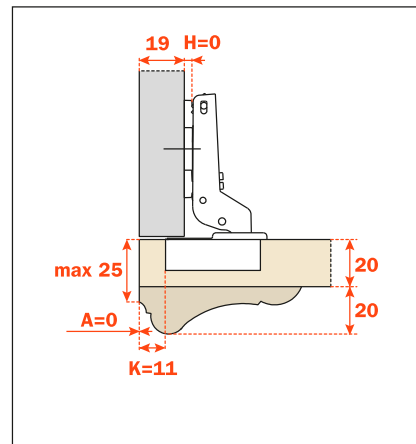
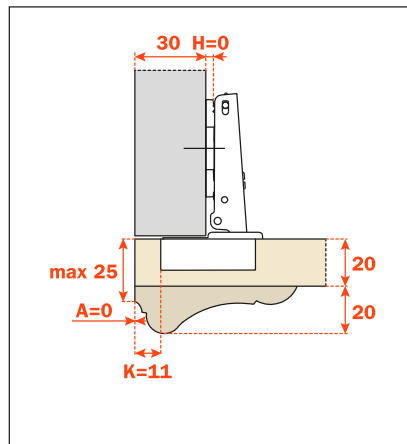
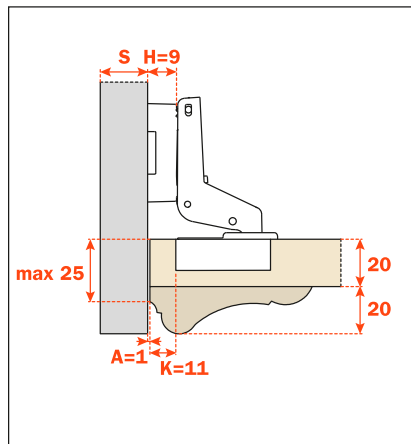
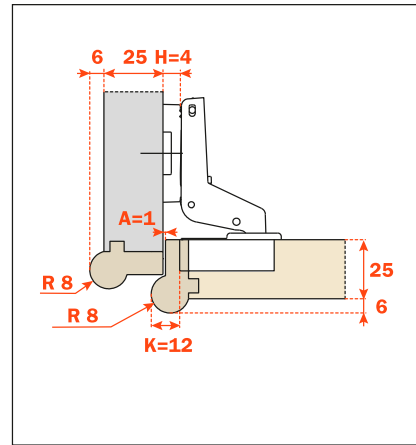
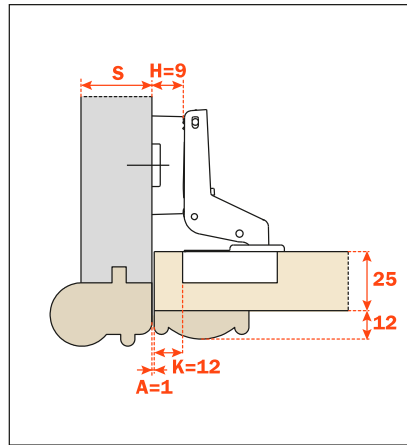
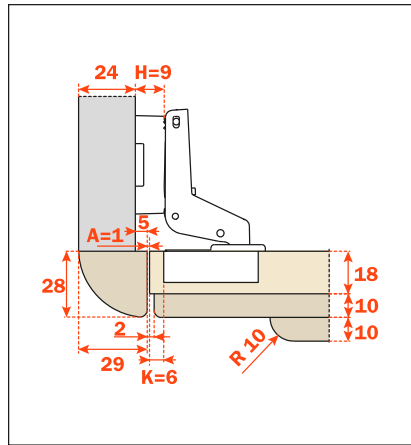
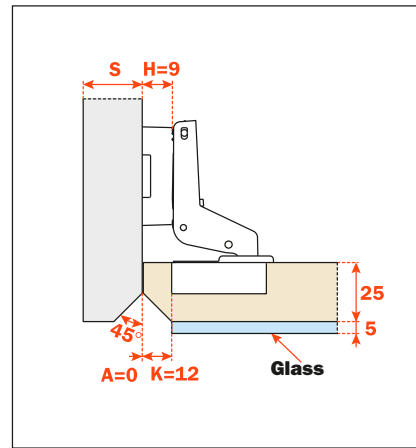
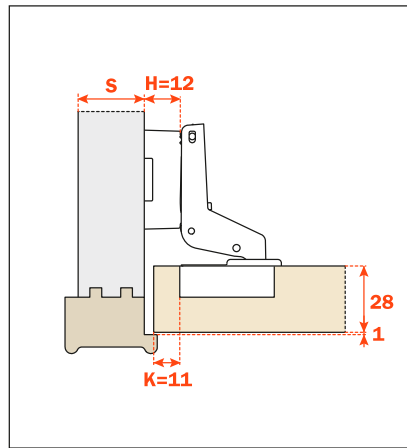
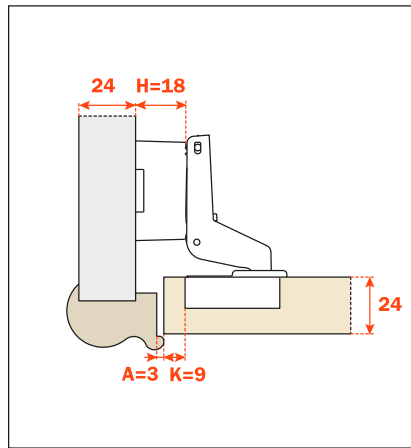

Series 300



Hinges with a small operating profile.
Bright nickel plated steel cup and arm.
Dimensions of the \varnothing 35 mm cup.

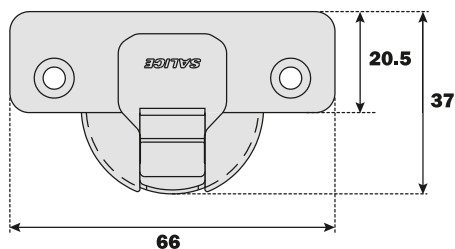

Constant "L" value of 0.7 mm (it does not change during side adjustment).

Approx. number of hinges required according to the door dimension and weight.

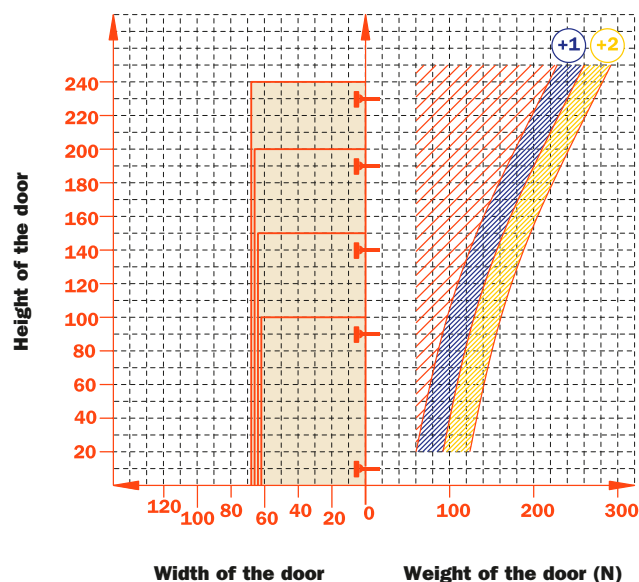

Adjustments

Compensating side adjustment from -1.5 mm to +3 mm.
Height adjustment \pm 1.5 mm by cam.
Depth adjustment with Series 300 mounting plates +2.8 mm.
Anti-sliding safety stop.

Mounting plates

Asymmetrical bright nickel plated die-cast Series 300 mounting plates.
Positioning with pre-determined stop.

N.B. : Use POZIDRIVE No. 2 screwdrivers for all screws.

	<p>48 $\varnothing 35$ 6 94° A</p>	<p>45 $\varnothing 35$ 9.5 94° P</p>	<p>52 $\varnothing 35$ 5.5 94° U</p>
<p>Wood screw</p>			
	<p>48 $\varnothing 35$ $\varnothing 10$ 6 94° B</p>	<p>45 $\varnothing 35$ $\varnothing 8$ 9.5 94° R</p>	<p>52 $\varnothing 35$ $\varnothing 10$ 5.5 94° W</p>
<p>Dowel</p>			

**Use this table to identify the available drillings and fixings.
 Fill the third position of the hinge code number with the letter or the number corresponding to your choice. I.e.: C3_BA99.**

↑
 Fill this position with the chosen letter or number.



Technical information

Hinges with just 45 mm operating profile.
 11 mm deep metal cup.
 94° opening.
 Possible drilling distance on the door (K): from 3 to 9 mm.
 Compatible with all traditional Series 300 mounting plates.

Space needed to open the door

	T=	19	20	21	22	23	24	25	26	27	28	29	30	31	32	33	34	35
K=3	A=	0.1	0.2	0.3	0.4	0.5	0.7	0.8	1.0	1.6	2.6	3.5	4.5	5.4	6.4	7.4	8.3	9.3
K=4	A=	0.1	0.2	0.3	0.4	0.5	0.7	0.8	1.0	1.2	1.9	2.8	3.8	4.7	5.7	6.6	7.6	8.6
K=5	A=	0.1	0.2	0.3	0.4	0.5	0.7	0.8	1.0	1.2	1.4	2.2	3.1	4.1	5.0	5.9	6.9	7.8
K=6	A=	0.1	0.2	0.3	0.4	0.5	0.6	0.8	1.0	1.2	1.4	1.7	2.6	3.5	4.4	5.3	6.2	7.2
K=7	A=	0.1	0.2	0.3	0.4	0.5	0.6	0.8	1.0	1.1	1.3	1.6	2.1	3.0	3.8	4.7	5.6	6.5
K=8	A=	0.1	0.2	0.3	0.4	0.5	0.6	0.8	0.9	1.1	1.3	1.6	1.8	2.5	3.3	4.2	5.1	6.0
K=9	A=	0.1	0.2	0.3	0.4	0.5	0.6	0.8	0.9	1.1	1.3	1.5	1.8	2.1	2.9	3.7	4.6	5.4

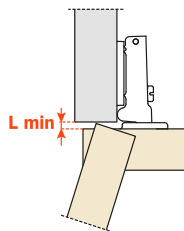
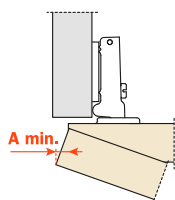

K=	3	4	5	6	7	8	9
L=	0.0	0.0	0.0	0.0	0.0	0.3	1.3

The above values are calculated on the assumption that the doors have square edges. They are reduced if the doors have radiussed edges.

Projection of the door

Projection of the door from the cabinet side at the max. opening. The figures are based on a straight arm hinge, H=0 mm thickness of mounting plate and K value = 3 mm.

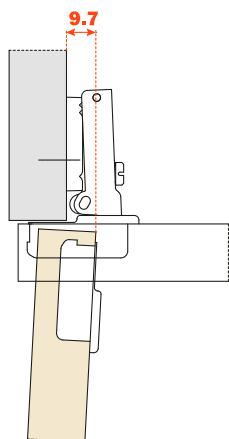

“C” value

With this formula you can obtain the max. thickness of the moulded door that can be opened without touching adjacent carcass sides, doors or walls, whilst bearing in mind the above L-K-T values.

$$C = 22.5 + K + A$$

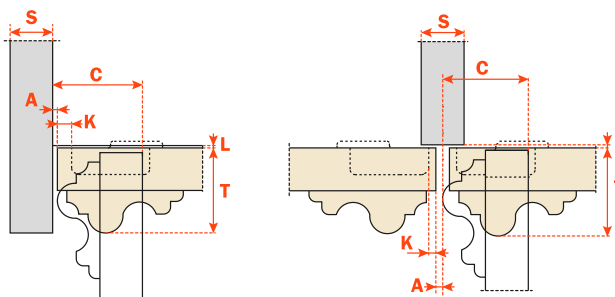

Packing

Boxes 300 pcs.
Pallets 7.200 pcs.

Use these formulas to determine the type of hinge arm, the drilling distance "K" and the height of the mounting plate "H" which is necessary to solve each application problem.

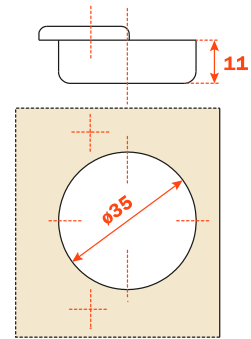

CA sprung hinge

Use the tables "Drillings and fixings" at page 119 to complete the code number of the desired hinge.

Arm 0

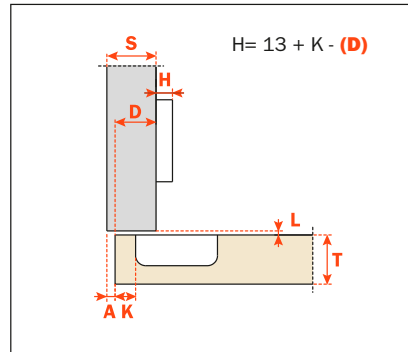

CA - C3_BA99

Series 800



Bright nickel plated steel cup and arm.
 Dimensions of the Ø 35 mm cup.

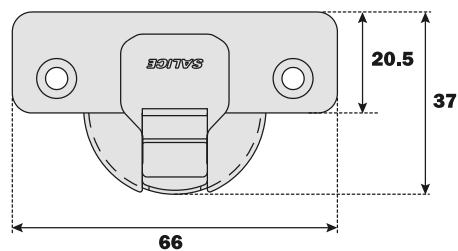

Approx. number of hinges required according to the door dimension and weight.

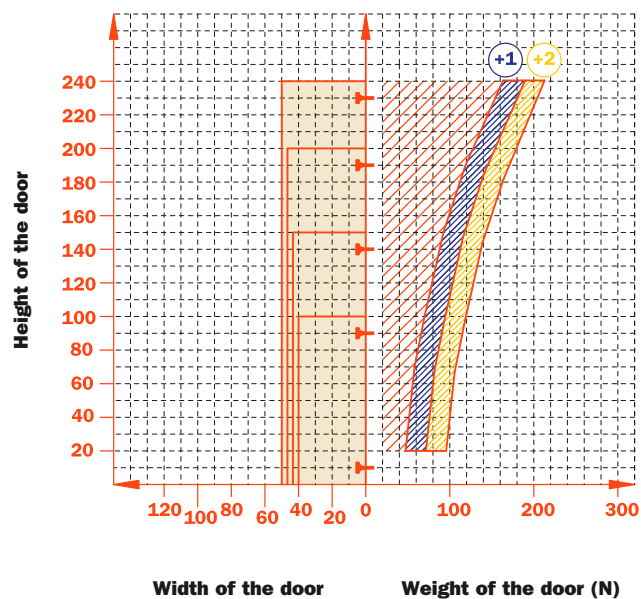





Adjustments

Side adjustment from -1.5 mm to +4.5 mm.
 Height adjustment ±2 mm.
 Depth adjustment from -1.5 mm to +3 mm.

Mounting plates

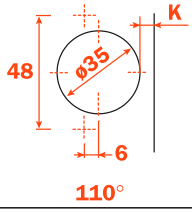
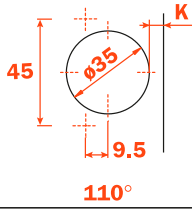
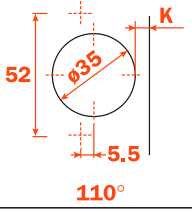
Symmetrical and asymmetrical bright nickel plated steel Series 200 mounting plates.
NOT COMPATIBLE with Series 200 die-cast mounting plates.

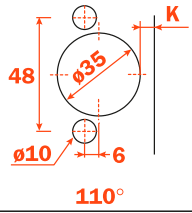
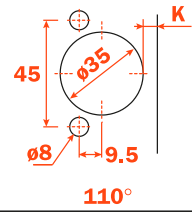
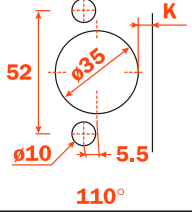
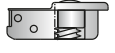
N.B. : Use POZIDRIVE No. 2 screwdrivers for all screws.

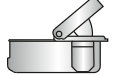
			
Wood screw 	A	P	U
			
Rapido 	6	7	2
Dowel 	B	R	W
Logica 	I	J	Q

Use this table to identify the available drillings and fixings.
 Fill the third position of the hinge code number with the letter or the number corresponding to your choice. I.e.: C8_6C99.

↑
 Fill this position with the chosen letter or number.



Technical information

When a greater opening angle is required.
 11 mm deep metal cup.
 110° opening.
 Possible drilling distance on the door (K): from 3 to 6 mm.
 Compatible with all traditional steel Series 200 mounting plates.

Space needed to open the door

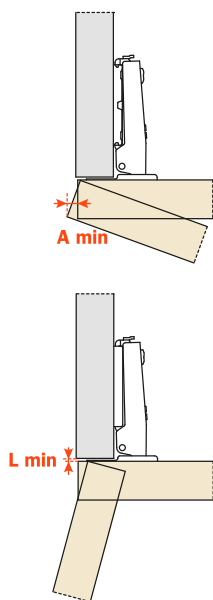

	T=	16	17	18	19	20	21	22	23	24	25	26
K=3	A=	0.5	0.7	0.9	1.2	1.5	1.8	2.4	3.7	5.1	6.5	7.8
K=4	A=	0.5	0.7	0.9	1.2	1.5	1.8	2.1	2.7	4.1	5.5	6.8
K=5	A=	0.5	0.7	0.9	1.2	1.5	1.8	2.1	2.6	3.1	4.1	5.4
K=6	A=	0.5	0.7	0.9	1.2	1.5	1.8	2.1	2.5	3.0	3.5	4.4

	T=	16	17	18	19	20	21	22	23	24	25	26
K=3	L=	0.0	0.0	0.0	0.0	0.2	0.5	0.8	1.1	1.4	1.7	1.9
K=4	L=	0.0	0.0	0.3	0.6	0.9	1.2	1.4	1.7	2.0	2.3	2.6
K=5	L=	1.1	1.3	1.6	1.8	2.1	2.3	2.6	2.9	3.1	3.4	3.6
K=6	L=	2.0	2.3	2.5	2.8	3.1	3.3	3.6	3.8	4.3	4.3	4.6

The above values are calculated on the assumption that the doors have square edges. They are reduced if the doors have radiussed edges.

Projection of the door

Projection of the door from the cabinet side at the max. opening. The figures are based on a straight arm hinge, H=0 mm thickness of mounting plate and K value = 3 mm.

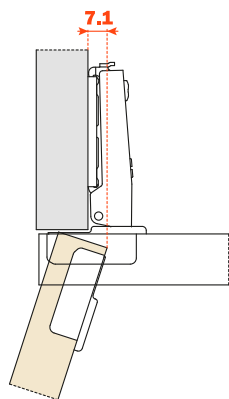

“C” value

With this formula you can obtain the max. thickness of the moulded door that can be opened without touching adjacent carcass sides, doors or walls, whilst bearing in mind the above L-K-T values.

$$C=20 + K + A$$

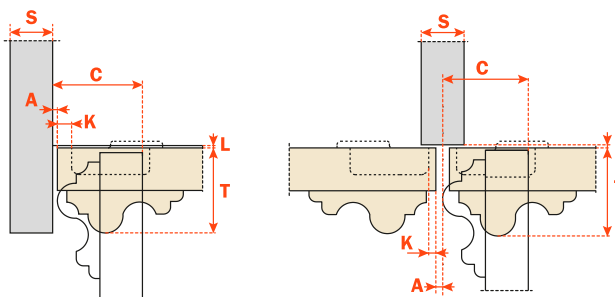

Packing

Boxes 300 pcs.
Pallets 7.200 pcs.

CA sprung hinge
CL unsprung hinge

Use these formulas to determine the type of hinge arm, the drilling distance "K" and the height of the mounting plate "H" which is necessary to solve each application problem.

Use the tables "Drillings and fixings" at page 125 to complete the code number of the desired hinge.

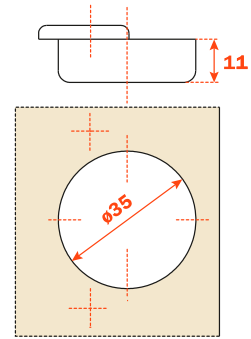
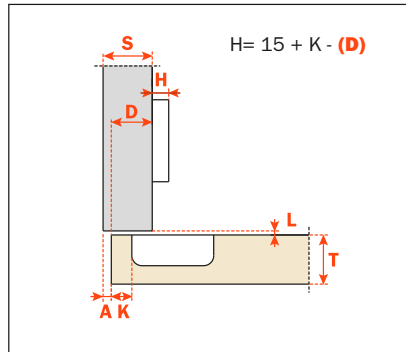
**Arm 0**

CA - C8_6C99
CL - C8_4C99

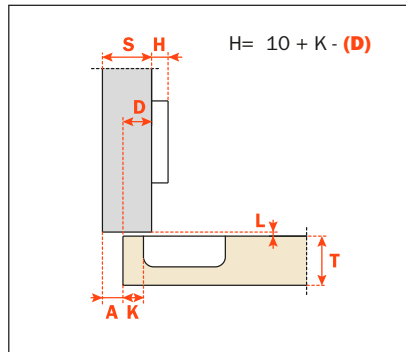
Arm 5

CA - C8_6J99
CL - C8_4J99

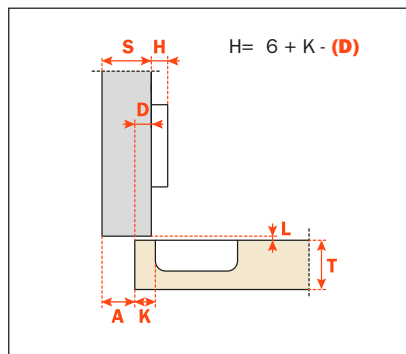
Arm 9

CA - C8_6L99
CL - C8_4L99

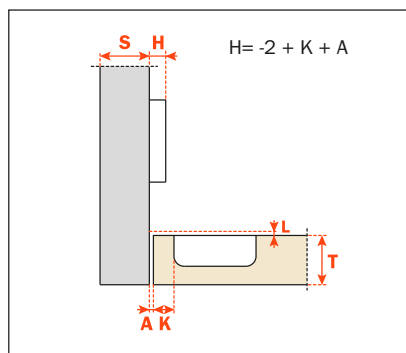
Arm 17

CA - C8_BS99
CL - C8_AS99

94° Opening

Series 900



Bright nickel plated steel cup and arm.
Dimensions of the Ø 35 mm cup.

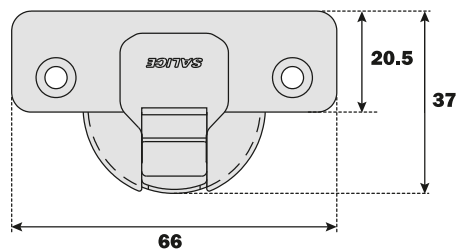

Approx. number of hinges required according to the door dimension and weight.

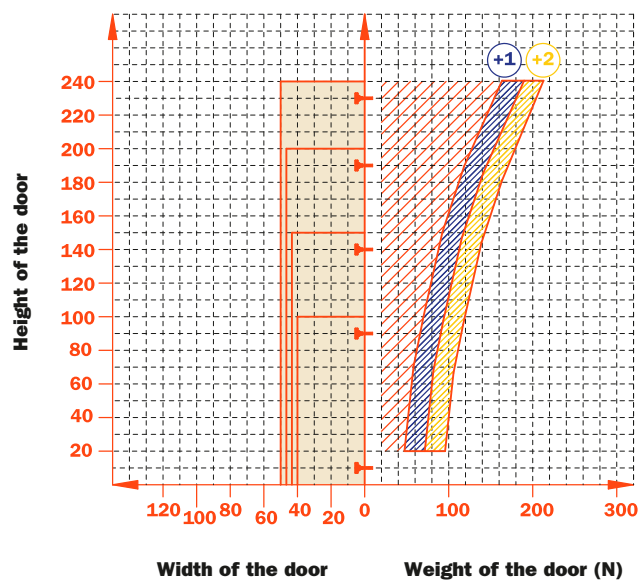

Adjustments

Side adjustment from -1.5 mm to +4 mm.
Height adjustment ±2 mm.
Depth adjustment +2.5 mm.

Mounting plates

Symmetrical and asymmetrical bright nickel plated steel or die-cast Series 200 mounting plates.
NOT COMPATIBLE with Series 200 mounting plates with negative height.

N.B. : Use POZIDRIVE No. 2 screwdrivers for all screws.

Drillings and fixings

Wood screw 	A	P	U
Rapido 	6	7	2
Dowel 	B	R	W
Logica 	I	J	Q

Use this table to identify the available drillings and fixings.

Fill the third position of the hinge code number with the letter or the number corresponding to your choice. I.e.: C9_6C99.

↑
Fill this position with the chosen letter or number.



Technical information

For doors with a minimum thickness of 13mm, or with moulded profiles.

11 mm deep metal cup.

110° opening.

Possible drilling distance on the door (K): from 3 to 6 mm.

Compatible with all traditional Series 200 mounting plates.

NOT COMPATIBLE with Domi snap-on mounting plates.

Space needed to open the door

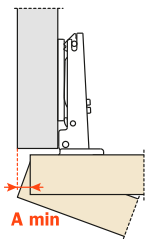

	T=	16	17	18	19	20	21	22	23	24	25	26
K=3	A=	0.5	0.7	0.9	1.2	1.5	1.8	2.4	3.7	5.1	6.5	7.8
K=4	A=	0.5	0.7	0.9	1.2	1.5	1.8	2.1	2.7	4.1	5.5	6.8
K=5	A=	0.5	0.7	0.9	1.2	1.5	1.8	2.1	2.6	3.1	4.1	5.4
K=6	A=	0.5	0.7	0.9	1.2	1.5	1.8	2.1	2.5	3.0	3.5	4.4

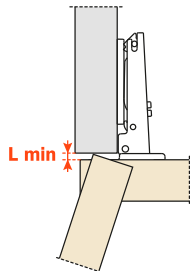

	T=	16	17	18	19	20	21	22	23	24	25	26
K=3	L=	0.0	0.0	0.0	0.0	0.2	0.5	0.8	1.1	1.4	1.7	1.9
K=4	L=	0.0	0.0	0.3	0.6	0.9	1.2	1.4	1.7	2.0	2.3	2.6
K=5	L=	1.1	1.3	1.6	1.8	2.1	2.3	2.6	2.9	3.1	3.4	3.6
K=6	L=	2.0	2.3	2.5	2.8	3.1	3.3	3.6	3.8	4.3	4.3	4.6

The above values are calculated on the assumption that the doors have square edges. They are reduced if the doors have radiussed edges.

Projection of the door

Projection of the door from the cabinet side at the max. opening. The figures are based on a straight arm hinge, H=0 mm thickness of mounting plate and K value = 3 mm.

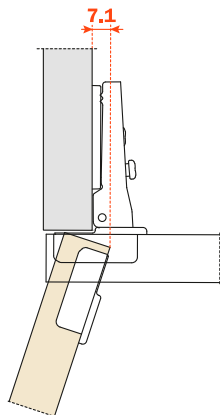

“C” value

With this formula you can obtain the max. thickness of the moulded door that can be opened without touching adjacent carcass sides, doors or walls, whilst bearing in mind the above L-K-T values.

$C = 20 + K + A$

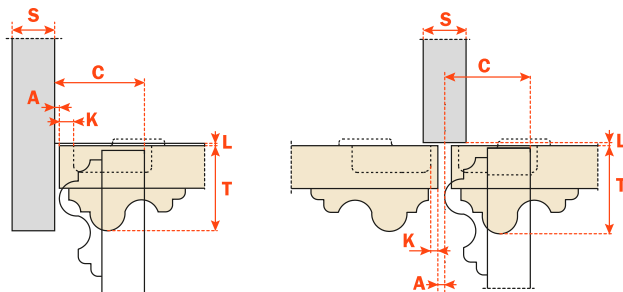

Packing

Boxes 300 pcs.
Pallets 7.200 pcs.

Use these formulas to determine the type of hinge arm, the drilling distance "K" and the height of the mounting plate "H" which is necessary to solve each application problem.

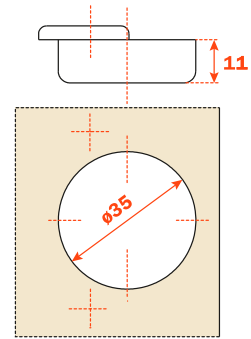
**CA sprung hinge**

Use the tables "Drillings and fixings" at page 131 to complete the code number of the desired hinge.

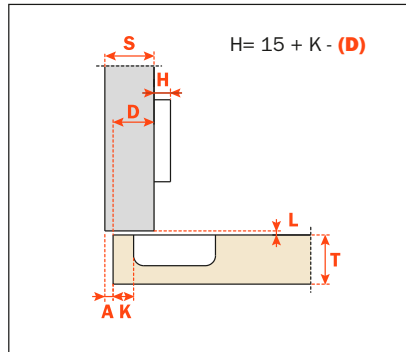
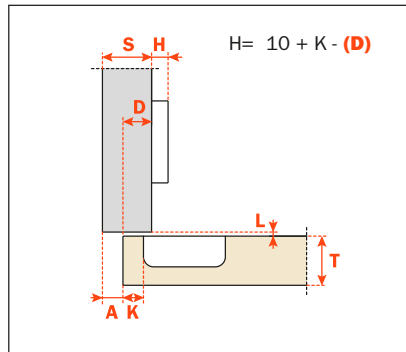
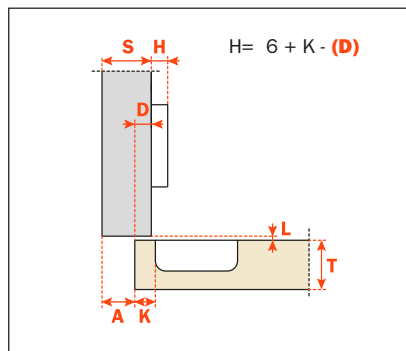
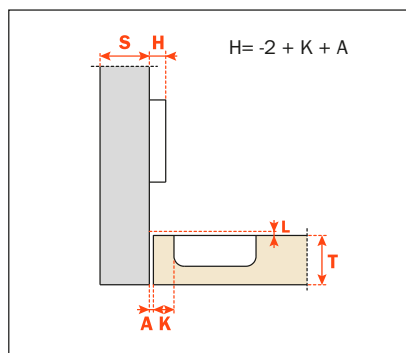
Arm 0**CA - C9_6C99****Arm 5****CA - C9_6J99****Arm 9****CA - C9_6L99****Arm 17****CA - C9_BS99****94° Opening**

For metal profiles



For metal profiles



Technical information

Hinges for the Practical system have been developed for use with special metal profiles. The particular fixing system does not require any profile working.

The hinge can be therefore assembled at any point of the frame. 105° opening.
Compatible with all traditional Series 200 mounting plates and with all Domi snap-on mounting plates.

Packing

Boxes 150 pcs.
Pallets 3.600 pcs.

CA sprung hinge

Arm 0

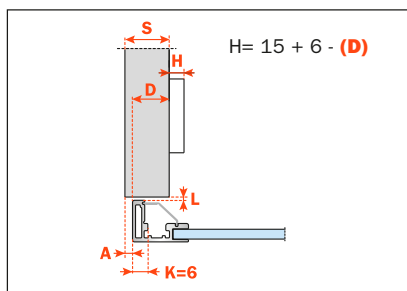

CA - C206A99

Arm 5

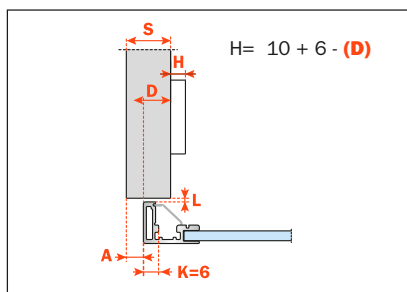

CA - C206D99

Arm 9

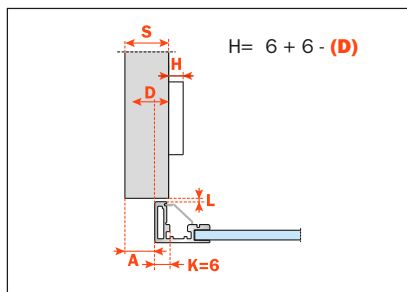

CA - C206G99

Arm 17

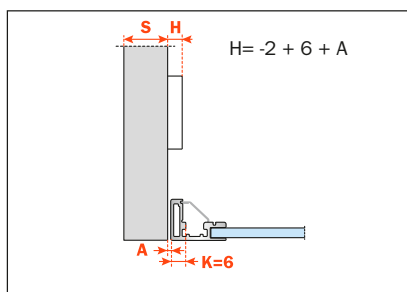

CA - C206P99



Technical information

Hinges for doors with positive angled assembly. Hinges for the Practical system have been developed for use with special metal profiles. The particular fixing system does not require any profile working.

The hinge can be therefore assembled at any point of the frame. 105° opening. Compatible with all traditional Series 200 mounting plates and with all Domi snap-on mounting plates.

Packing

Boxes 150 pcs.
Pallets 3.600 pcs.

CA sprung hinge

Arm 30°

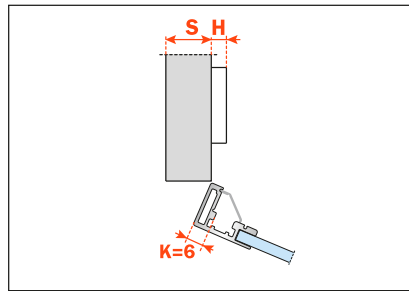

CA - C206E99

Arm 45°

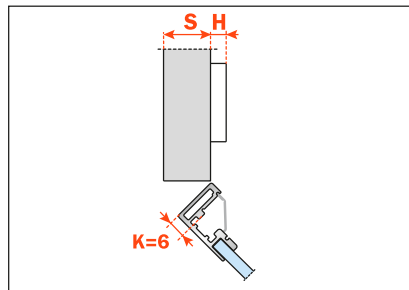

CA - C206M99

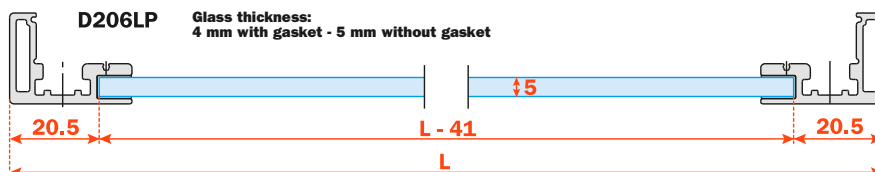
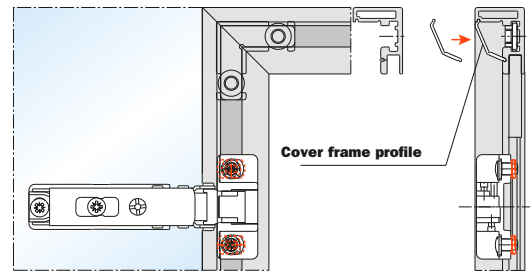
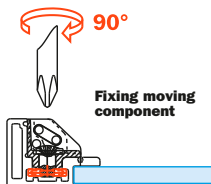
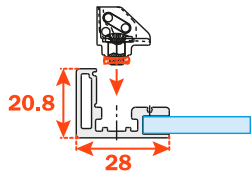



Technical information

Crampon hinges.
For cabinet sides with 37x32 mm standard drilling.
Hinges for the Practical system have been developed for use with special metal profiles.
The particular fixing system does not require any profile working.

The hinge can be therefore assembled at any point of the frame.
 105° opening.
 Compatible with all traditional Series 200 mounting plates and with all Domi snap-on mounting plates.

Packing

Boxes 150 pcs.
 Pallets 3.600 pcs.

E min:

61 mm for Series 200 mounting plates.
 70 mm for Domi snap-on mounting plates.
 74 mm for Domi snap-on mounting plates with back cam.

CA sprung hinge

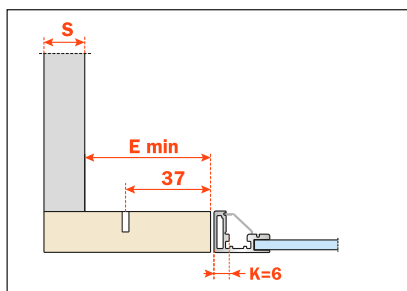

CA - C206N99AC

Heights of mounting plates for every assembly.

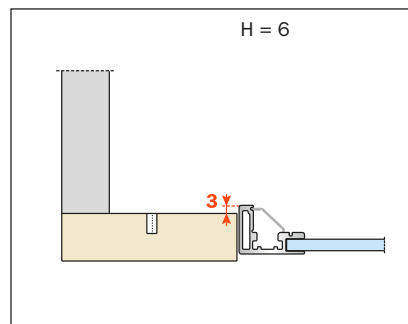
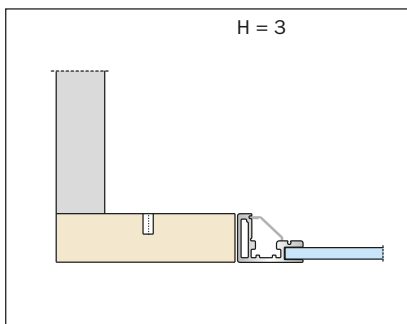
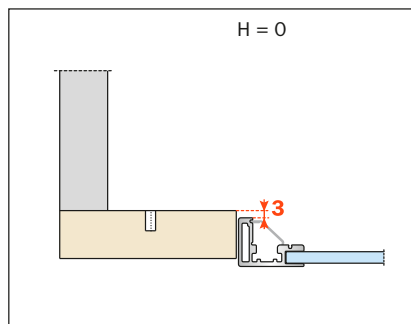



Technical information

Crampon hinges.

For smaller spaces with 15x32 mm drilling.

Hinges for the Practical system have been developed for use with special metal profiles.

The particular fixing system does not require any profile working.

The hinge can be therefore assembled at any point of the frame. 105° opening.

Compatible with all traditional Series 200 mounting plates, 28x32 mm drilling.

NOT COMPATIBLE with Domi snap-on mounting plates.

Packing

Boxes 150 pcs.

Pallets 3.600 pcs.

CA sprung hinge

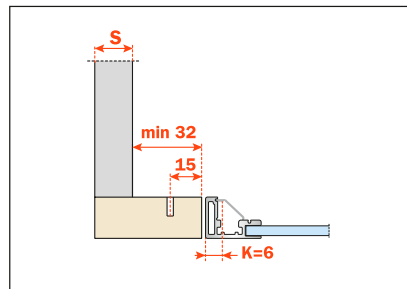

CA - C206N99

Heights of mounting plates for every assembly.

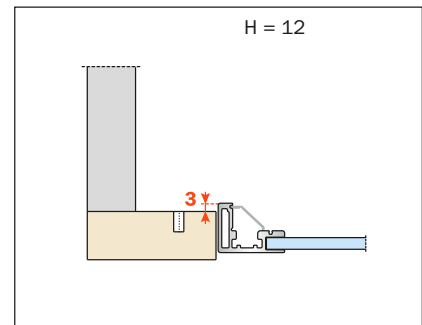
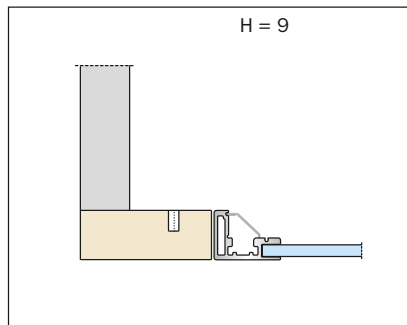
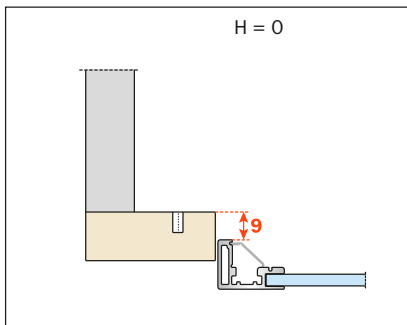

D206BS5

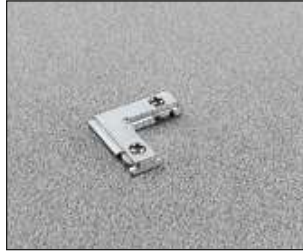

Corner connector with 2 fixing screws for the frame assembly

Packing
Boxes 600 pcs.

D206BS5L



Corner connector with 4 fixing screws for the frame assembly

Packing
Boxes 600 pcs.

D206HS5



Additional corner connector for the frame assembly

Packing
Boxes 600 pcs.

D206AG3000



Gasket for glass
3 m lengths

Packing
Boxes 120 pcs.

D206LP3000

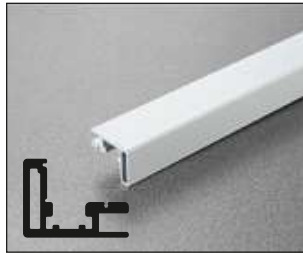

Frame for doors, glass to be inserted
3 m lengths

Packing
Boxes 12 pcs.

D206BL5



Adapter for single flap doors, drawer frontals and special applications

Packing
Boxes 150 pcs.

D206AA3000



Internal cover frame profile of moulded plastic
3 m lengths

Packing
Boxes 120 pcs.

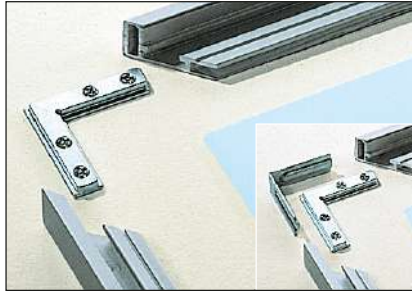

1) The profiles which make up the door are cut to length and the ends mitred at 45°.

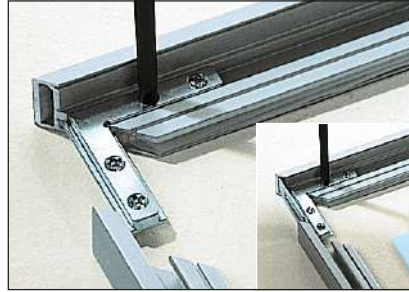

2) Insert the corner connector into the profile, recess and fix it by means of its premounted screw/screws. On large doors it is suggested to use the additional corner connector (small picture).



3) Repeat the same operation on the other profiles which make up the door. The glass will be applied before fixing the fourth and last profile.



4) Fix the hinges to the mounting plates and then assemble them onto the frame. The operation does not require any work on the door, as the hinge can be inserted at any point of the profile recess.



5) The hinge will be therefore at the exact position of the mounting plate on the cabinet side.



6) At this point it is sufficient to fix the hinge onto the profile by simply rotating the cams 90°.



7) Cut to length and mitre the internal frame cover profile also.



8) Complete the preparation of the door by inserting the internal frame cover profile with a simple pressure.



9) Where the hinges are located, cut the internal frame cover profile at the position of the same hinges.



10) Internal frame cover profile, moulded version.



11) Hinges for the Practical system represent the most practical, quickest and elegant solution for all types of furniture.



Technical information

Hinges specially developed for use with metal profiles.

105° opening.

We recommend the use of self-threading screws B 3.5 x 9.5 DIN 7982 to fix C2Z6 hinges.

Compatible with all traditional Series 200 mounting plates and with all Domi snap-on mounting plates.

Packing

Boxes 150 pcs.

Pallets 3.600 pcs.

CA sprung hinge

Arm 0

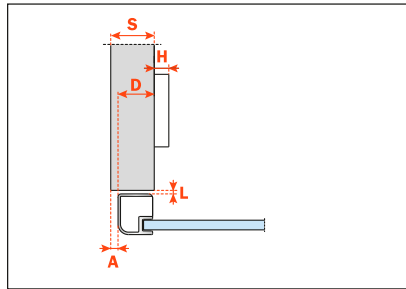

CA - C2Z6A99

Arm 5

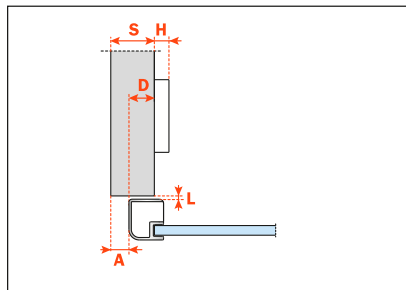

CA - C2Z6D99

Arm 9

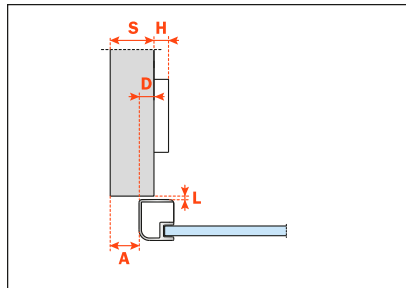

CA - C2Z6G99

Arm 17

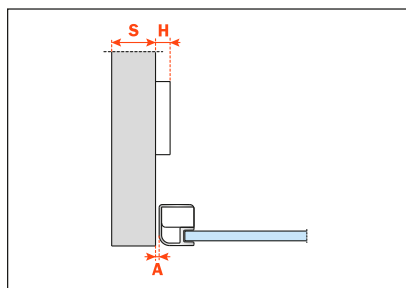

CA - C2Z6P99

Complementary hinges



Technical information

Hinges for doors with positive angled assembly.
Hinges specially developed for use with metal profiles.
 105° opening.

We recommend the use of self-threading screws B 3.5 x 9.5
 DIN 7982 to fix C2Z6 hinges.

Compatible with all traditional Series 200 mounting plates and
 with all Domi snap-on mounting plates.

Packing

Boxes 150 pcs.
 Pallets 3.600 pcs.

CA sprung hinge

Arm 30°

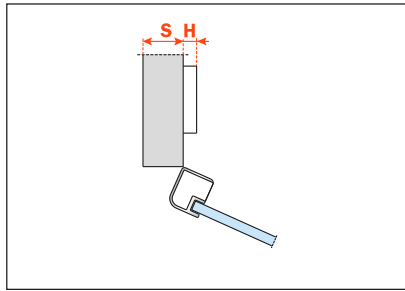

CA - C2Z6E99

Arm 45°

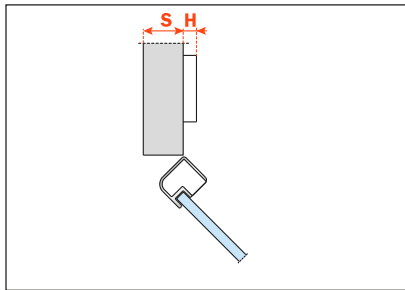

CA - C2Z6M99

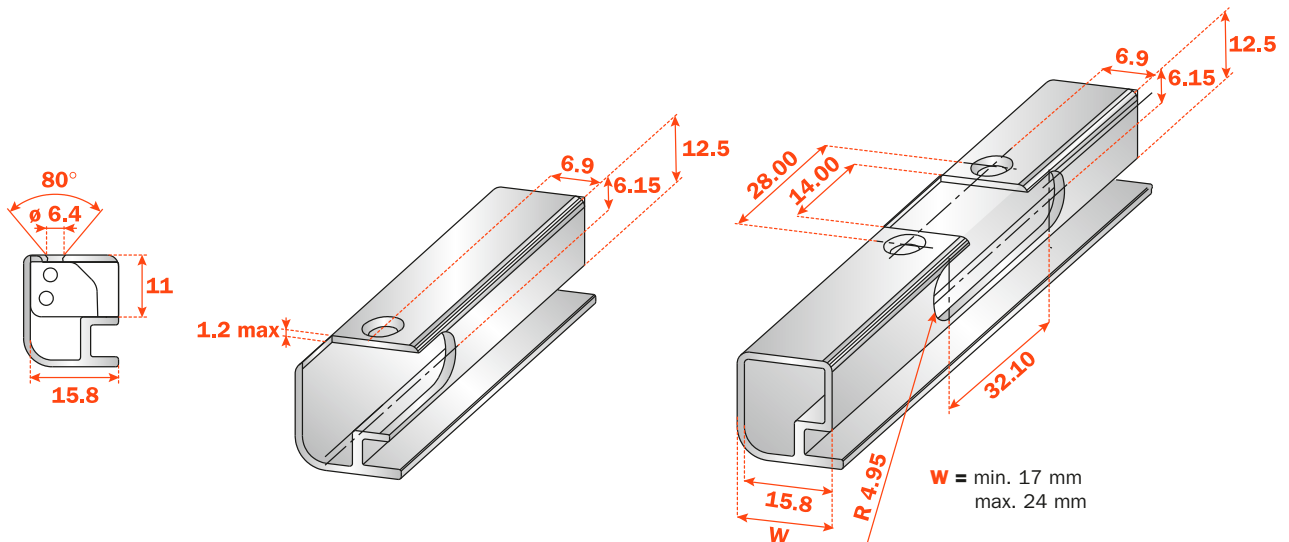



Technical information

Crampon hinges.
For cabinet sides with 37x32 mm standard drilling.
Hinges specially developed for use with metal profiles.
 105° opening.
 We recommend the use of self-threading screws B 3.5 x 9.5 DIN 7982 to fix C2Z6 hinges.
 Compatible with all traditional Series 200 mounting plates and with all Domi snap-on mounting plates.

Packing

Boxes 150 pcs.
 Pallets 3.600 pcs.

E min:

61 mm for Series 200 mounting plates.
 70 mm for Domi snap-on mounting plates.
 74 mm for Domi snap-on mounting plates with back cam.

CA sprung hinge

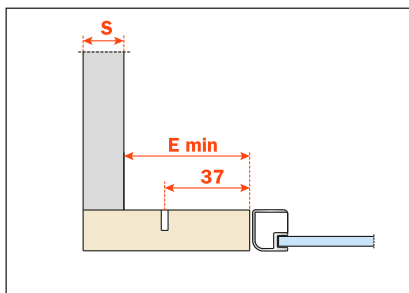

CA - C2Z6N99AC

Heights of mounting plates for every assembly.

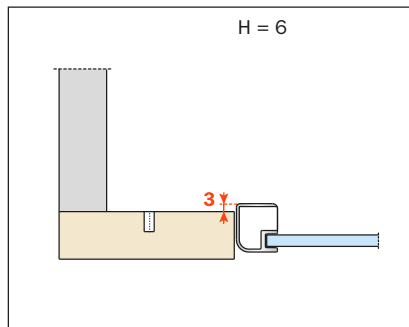
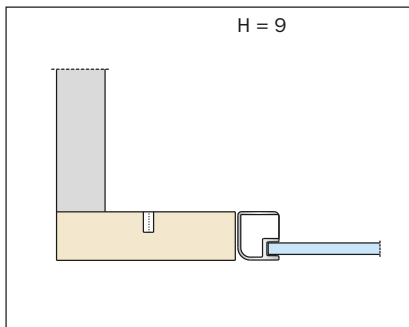
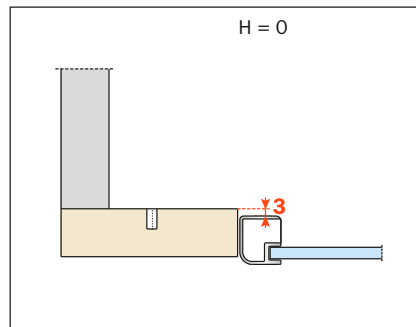

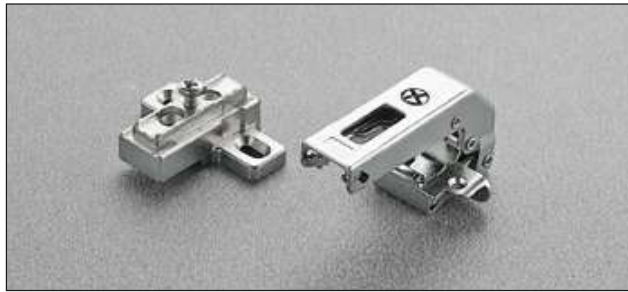

Technical information

Crampon hinges.

For smaller spaces with 15x32 mm drilling.

Hinges specially developed for use with metal profiles.

105° opening.

We recommend the use of self-threading screws B 3.5 x 9.5

DIN 7982 to fix C2Z6 hinges.

Compatible with all traditional Series 200 mounting plates, drilling 28x32 mm.

NOT COMPATIBLE with Domi snap-on mounting plates.

Packing

Boxes 150 pcs.

Pallets 3.600 pcs.

CA sprung hinge

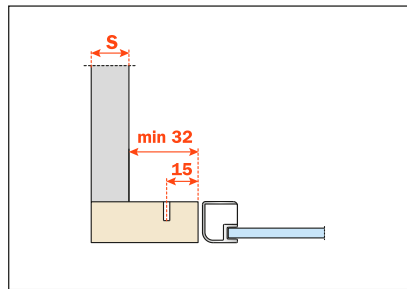

CA - C2Z6N99

Heights of mounting plates for every assembly.

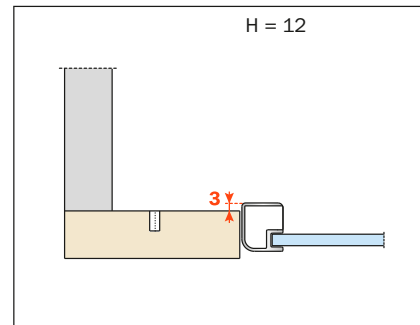
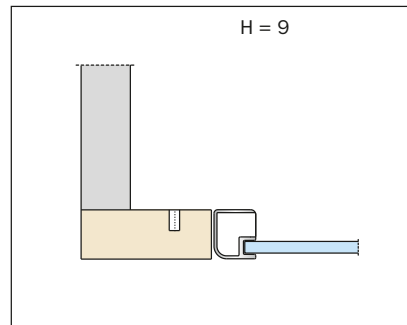
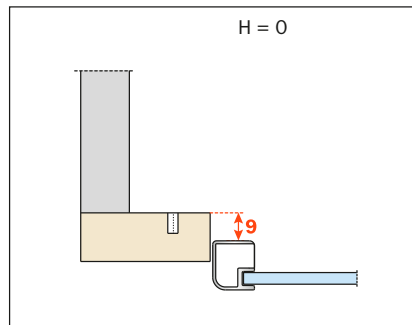



Technical information

Hinges specially developed for use with metal profiles, with spring-cover cup.

94° opening.

Compatible with all traditional Series 200 mounting plates and with all Domi snap-on mounting plates.

Packing

Boxes 150 pcs.

Pallets 3.600 pcs.

CA sprung hinge

Arm 0

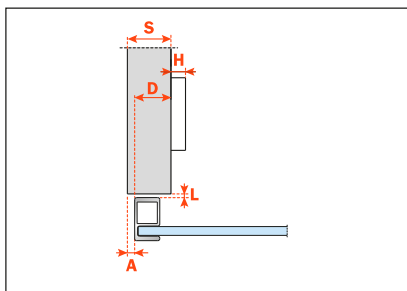

CA - C4Z7A99

Arm 5

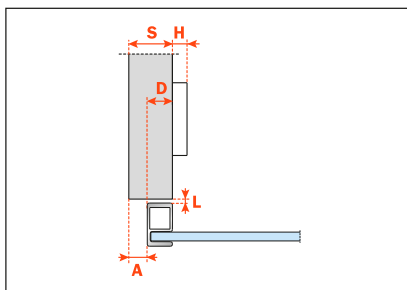

CA - C4Z7D99

Arm 9

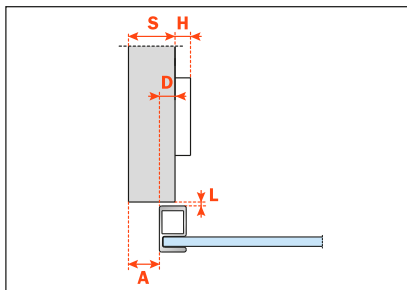

CA - C4Z7G99

Arm 17

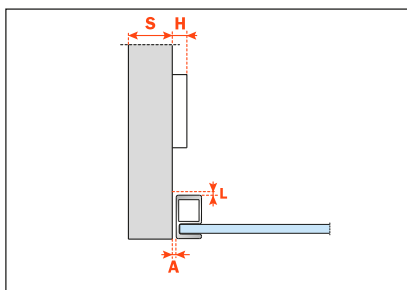

CA - C4Z7P99

Complementary hinges



Technical information

Hinges for doors with positive angled assembly and crampon hinges.

Hinges specially developed for use with metal profiles, with spring-cover cup.

94° opening.

Compatible with all traditional Series 200 mounting plates and with all Domi snap-on mounting plates.

Packing

Boxes 150 pcs.

Pallets 3.600 pcs.

CA sprung hinge

Arm 30°

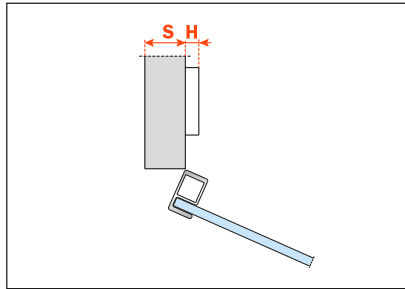

CA - C4Z7E99

Arm 45°

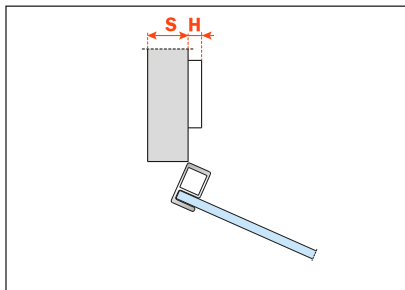

CA - C4Z7M99

Crampon

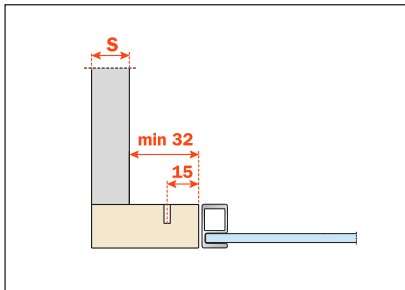

Crampon hinges. To be used only with Series 200 mounting plates for traditional assembly and drilling 28x32 mm.

CA - C4Z7N99

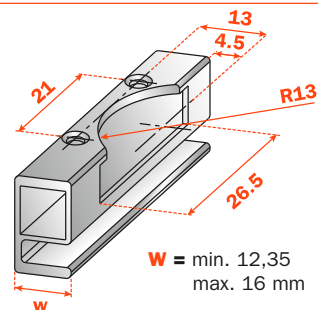
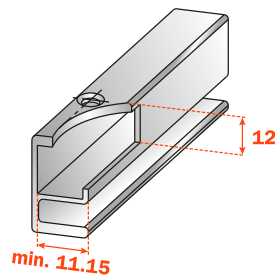
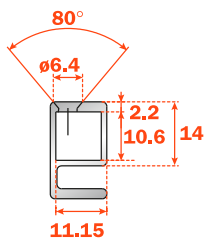

Mini hinges - Series 400



Mini hinges - Series 400

Compact, elegant, very strong mini hinge.
Bright nickel plated steel cup.
Bright nickel plated die-cast arm.
Dimensions of the \varnothing 26 mm cup.

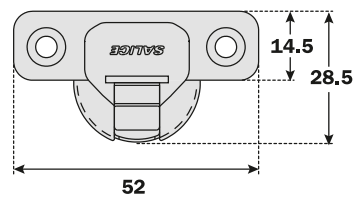

Constant "L" value of 0.7 mm (it does not change during side adjustment).

Approx. number of hinges required according to the door dimension and weight.

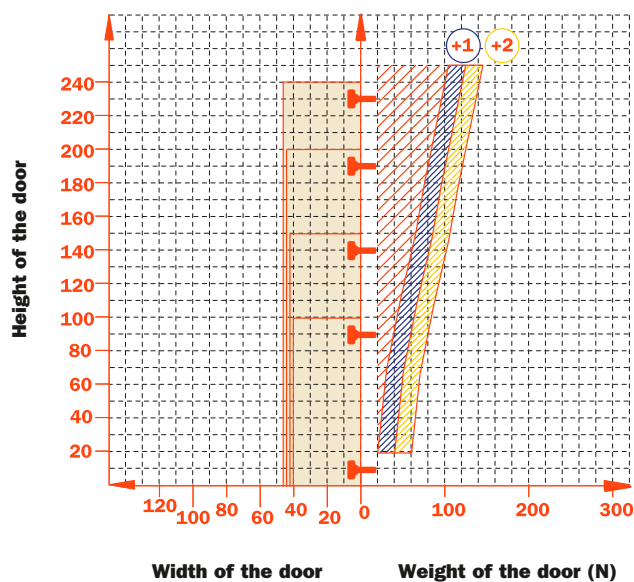

Adjustments

Compensated side adjustment from -0.5 mm to +5.5 mm.
 Height adjustment ± 2 mm.
 Depth adjustment with Series 200 mounting plates +2.8 mm.
 Depth adjustment with Domi mounting plates from -0.5 mm to +2.8 mm.

Mounting plates

Symmetrical and asymmetrical bright nickel plated steel or die-cast Series 200 mounting plates.
 Snap-on assembly on series Domi mounting plates.
 Positioning with pre-determined stop on traditional Series 200 mounting plates.

N.B. : Use POZIDRIVE No. 2 screwdrivers for all screws.

<p>Wood screw</p>	<p>A</p>	
<p>Dowel</p>	<p>B</p>	<p>R</p>

Use this table to identify the available drillings and fixings.
 Fill the third position of the hinge code number with the letter or the number corresponding to your choice. I.e.: C4_7A99.

↑
 Fill this position with the chosen letter or number.

Mini hinges - Series 400 - 94° opening



Technical information

11.5 mm deep metal cup.
 26 mm cup diameter.
 94° opening.
 Possible drilling distance on the door (K): from 3 to 8 mm.
 Compatible with all traditional Series 200 mounting plates and
 with all Domi snap-on mounting plates.

Space needed to open the door

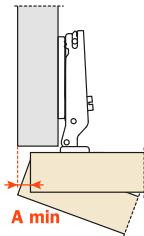

T=	16	17	18	19	20	21	22	23
K=3	A= 0.4	0.7	0.9	1.3	2.0	2.9	3.8	4.7
K=4	A= 0.4	0.6	0.9	1.1	1.6	2.4	3.3	4.2
K=5	A= 0.4	0.6	0.8	1.1	1.4	2.0	2.8	3.6
K=6	A= 0.4	0.6	0.8	1.0	1.2	1.8	2.4	3.2
K=7	A= 0.4	0.6	0.8	0.9	1.2	1.5	2.2	2.8
K=8	A= 0.4	0.6	0.8	0.9	1.2	1.5	1.9	2.6

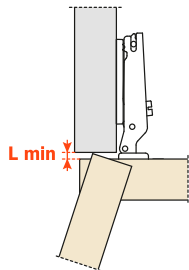

K=	3	4	5	6	7	8
L=	0.0	0.0	0.0	0.7	1.7	2.6

The above values are calculated on the assumption that the doors have square edges.
 They are reduced if the doors have radiused edges.

Projection of the door

Projection of the door from the cabinet side at the max. opening.
 The figures are based on a straight arm hinge, H=0 mm thickness
 of mounting plate and K value = 3 mm.

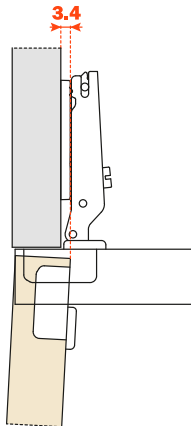

“C” value

With this formula you can obtain the max. thickness of the moulded
 door that can be opened without touching adjacent carcass sides,
 doors or walls, whilst bearing in mind the above L-K-T values.

$$C = 16.5 + K + A$$

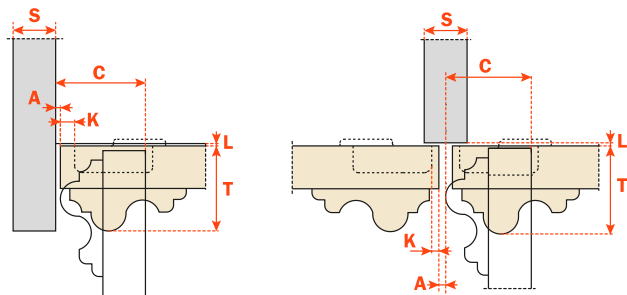

Packing

Boxes 300 pcs.
Pallets 7.200 pcs.

Use these formulas to determine the type of hinge arm, the drilling distance "K" and the height of the mounting plate "H" which is necessary to solve each application problem.

Use the tables "Drillings and fixings" at page 153 to complete the code number of the desired hinge.

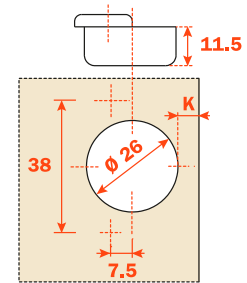
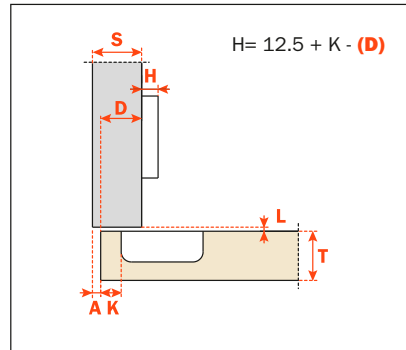
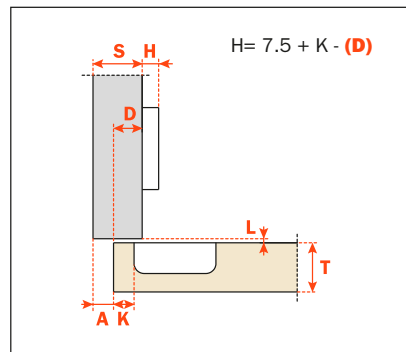
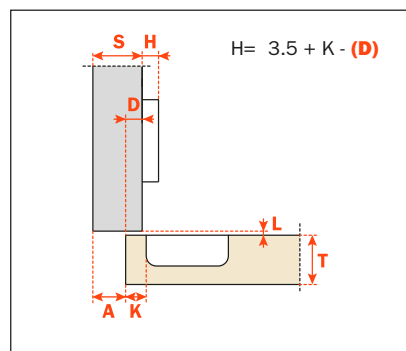
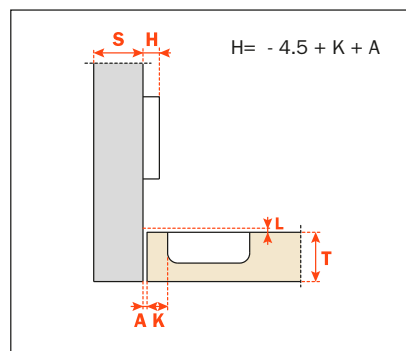
**Arm 0****CA - C4_7A99****Arm 5****CA - C4_7D99****Arm 9****CA - C4_7G99****Arm 17****CA - C4_7P99**



Technical information

Hinges for doors with positive angled assembly and crampon hinges.

11.5 mm deep metal cup.
 26 mm cup diameter.
 94° opening.
 Possible drilling distance on the door (K): from 3 to 8 mm.
 Compatible with all traditional Series 200 mounting plates and with all Domi snap-on mounting plates.

Packing

Boxes 150 pcs.
 Pallets 3.600 pcs.

CA sprung hinge

The solution of assembly problems where doors are mounted at a positive or negative angle requires the verification of drilling distances by a practical trial. Please do not hesitate to consult our technical support department for assistance.

Use the tables "Drillings and fixings" at page 153 to complete the code number of the desired hinge.

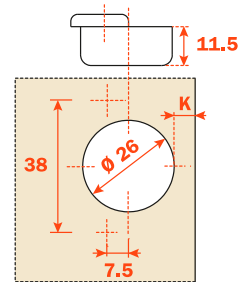

Arm 30°

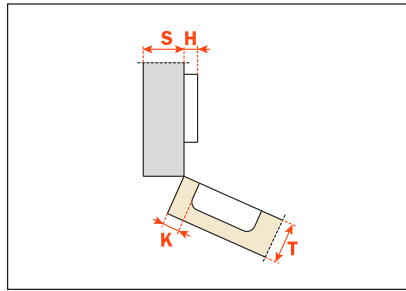

CA - C4_7E99

Arm 45°

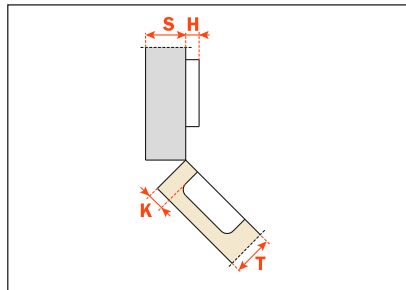

CA - C4_7M99

Crampon

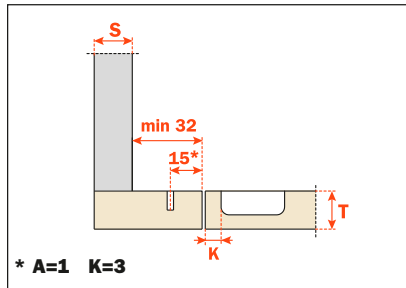

Crampon hinge to be used only with Series 200 mounting plates for traditional assembly and drilling 28x32mm.

CA - C4_7N99

Heights of mounting plates for every assembly.

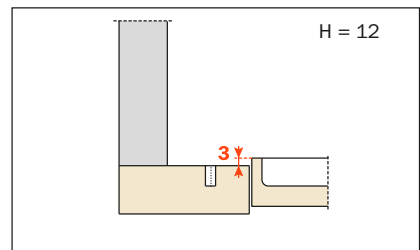
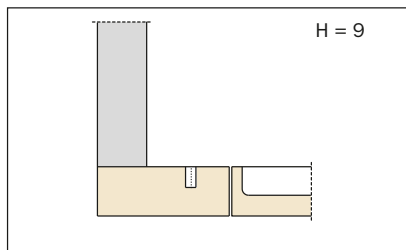
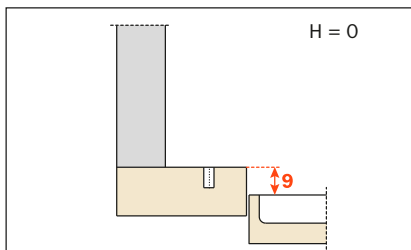

Mini hinges - Series 600



**Compact, elegant, very strong mini hinge.
Bright nickel plated steel cup and arm.
Dimensions of the \varnothing 26 mm cup.**

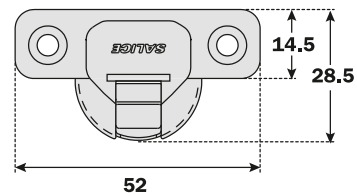

Constant "L" value of 0.7 mm (it does not change during side adjustment).

Approx. number of hinges required according to the door dimension and weight.

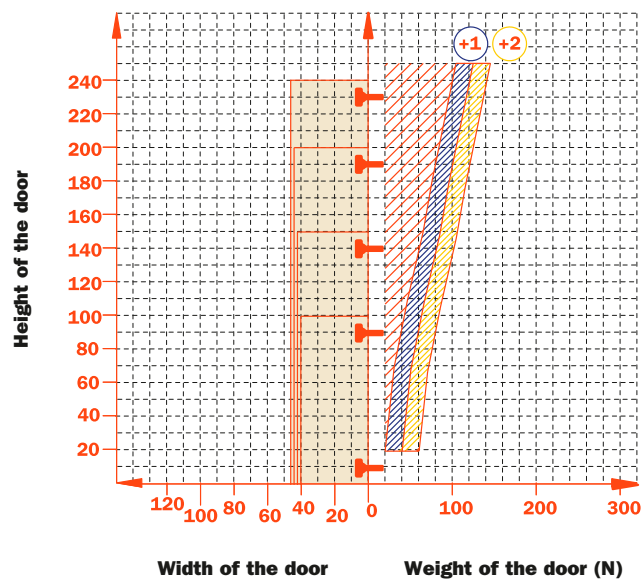

Adjustments

Side adjustment +5 mm. It is possible to recover the gap behind the door (the initial "L" value of 0.7 mm) simply by using the assembly stop located on the underside of the hinge.
Height adjustment ± 2 mm.
Depth adjustment with Series 200 mounting plates +2.5 mm.

Mounting plates

Symmetrical and asymmetrical bright nickel plated steel or die-cast Series 200 mounting plates.
Positioning with pre-determined stop on Series 200 traditional mounting plates.
NOT COMPATIBLE with Series 200 mounting plates with negative height.

N.B. : Use POZIDRIVE No. 2 screwdrivers for all screws.

<p>Wood screw</p>	<p>A</p>	
<p>Dowel</p>	<p>B</p>	<p>R</p>

Use this table to identify the available drillings and fixings.
 Fill the third position of the hinge code number with the letter or the number corresponding to your choice. I.e.: C6_7C99.

↑
 Fill this position with the chosen letter or number.

Mini hinges - Series 600 - 94° opening



Technical information

11.5 mm deep metal cup.
 26 mm cup diameter.
 94° opening.
 Possible drilling distance on the door (K): from 3 to 8 mm.
 Compatible with all traditional Series 200 mounting plates.
NOT COMPATIBLE with Domi snap-on mounting plates.

Space needed to open the door

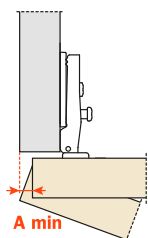

	T=	16	17	18	19	20	21	22	23
K=3	A=	0.4	0.7	0.9	1.3	2.0	2.9	3.8	4.7
K=4	A=	0.4	0.6	0.9	1.1	1.6	2.4	3.3	4.2
K=5	A=	0.4	0.6	0.8	1.1	1.4	2.0	2.8	3.6
K=6	A=	0.4	0.6	0.8	1.0	1.2	1.8	2.4	3.2
K=7	A=	0.4	0.6	0.8	0.9	1.2	1.5	2.2	2.8
K=8	A=	0.4	0.6	0.8	0.9	1.2	1.5	1.9	2.6

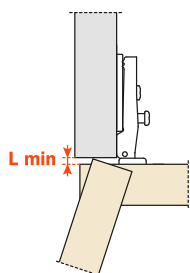

K=	3	4	5	6	7	8
L=	0.0	0.0	0.0	0.7	1.7	2.6

The above values are calculated on the assumption that the doors have square edges. They are reduced if the doors have radiussed edges.

Projection of the door

Projection of the door from the cabinet side at the max. opening. The figures are based on a straight arm hinge, H=0 mm thickness of mounting plate and K value = 3 mm.

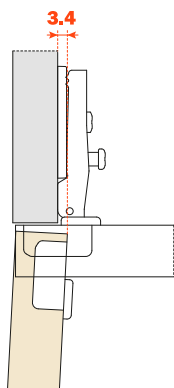

“C” value

With this formula you can obtain the max. thickness of the moulded door that can be opened without touching adjacent carcass sides, doors or walls, whilst bearing in mind the above L-K-T values.

$$C = 16.5 + K + A$$

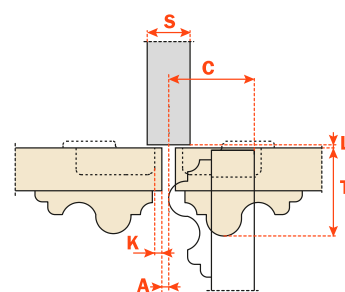
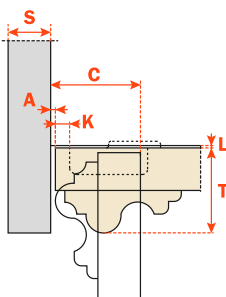

Packing

Boxes 600 pcs.
Pallets 14.400 pcs.

CA sprung hinge

Use these formulas to determine the type of hinge arm, the drilling distance "K" and the height of the mounting plate "H" which is necessary to solve each application problem.

Use the tables "Drillings and fixings" at page 159 to complete the code number of the desired hinge.

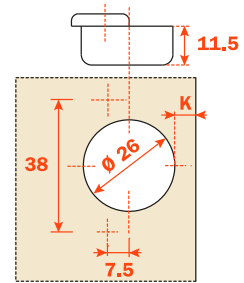
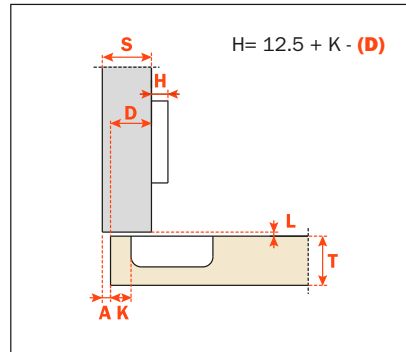
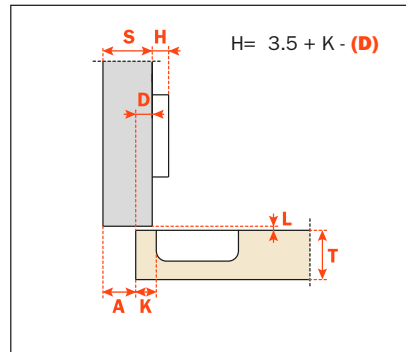
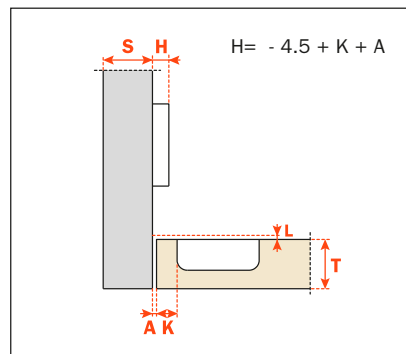
Arm **0****CA - C6_7C99**Arm **9****CA - C6_7L99**Arm **17****CA - C6_7S99**



Technical information

For wooden doors with positive angled assembly.
 11,5 mm deep metal cup.
 94° opening.
 Possible drilling distance on the door (K): from 3 to 8 mm.
 Compatible with all traditional Series 200 mounting plates.
NOT COMPATIBLE with Domi snap-on mounting plates.

Packing

Boxes 300 pcs.
 Pallets 7.200 pcs.

CA sprung hinge

The solution of assembly problems where doors are mounted at a positive or negative angle requires the verification of drilling distances by a practical trial. Please do not hesitate to consult our technical support department for assistance.

Use the tables "Drillings and fixings" at page 159 to complete the code number of the desired hinge.

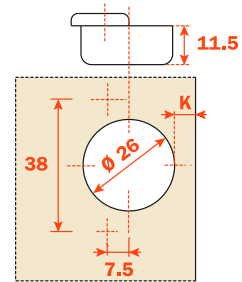

Arm 24°

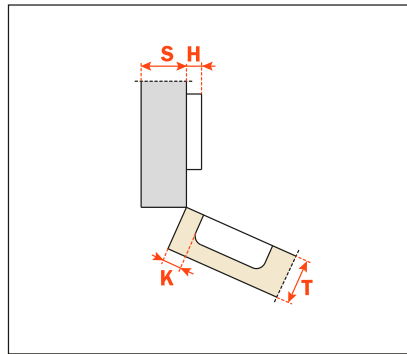

CA - C6_7U99

Arm 30°

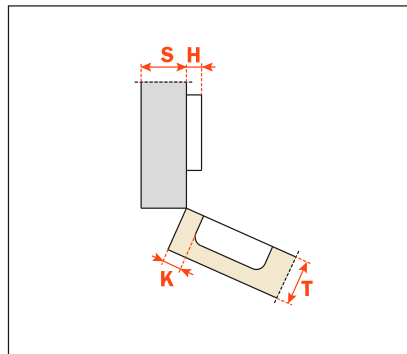

CA - C6_7E99

Arm 45°

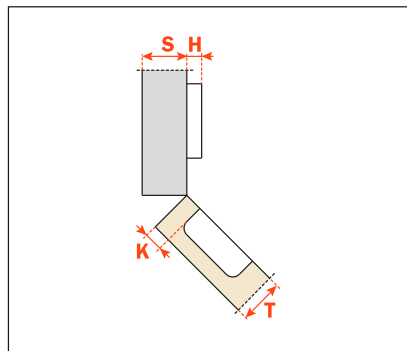

CA - C6_7M99

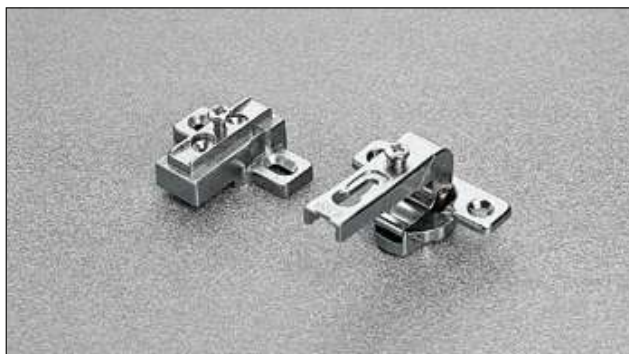

Technical information

Crampon hinges.

For smaller spaces with 15x32 mm drilling.

11.5 mm deep metal cup.

94° opening.

Possible drilling distance on the door (K): from 3 to 8 mm.

Compatible with all traditional Series 200 mounting plates, 28x32 mm drilling.

NOT COMPATIBLE with Domi snap-on mounting plates.

Packing

Boxes 300 pcs.

Pallets 7.200 pcs.

Use the tables "Drillings and fixings" at page 159 to complete the code number of the desired hinge.

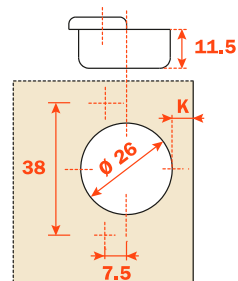

CA sprung hinge

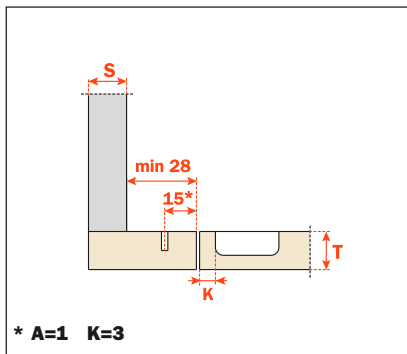

CA - C6_7N99

Heights of mounting plates for every assembly.

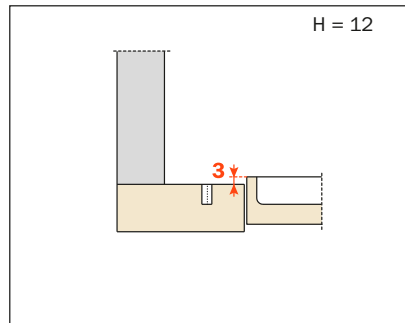
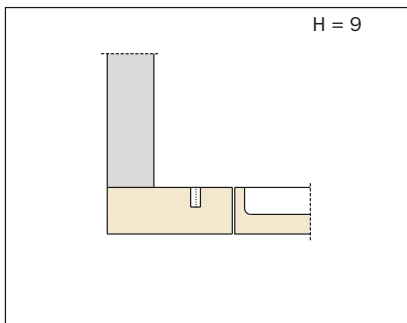
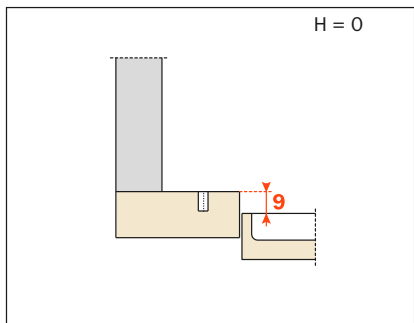

Mini hinges - Series 600 - 94° opening

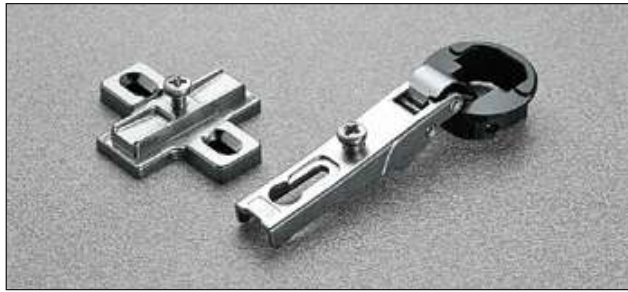

Technical information

Hinges for glass doors.

Hole diameter 26 mm.

94° opening.

For use with glass from 4 mm to 6 mm thickness.

Possible drilling distance on the door (K): from 5.5 to 6.5 mm.

Compatible with all traditional Series 200 mounting plates.

NOT COMPATIBLE with Domi snap-on mounting plates.

Packing

Boxes 300 pcs.

Pallets 7.200 pcs.

Use these formulas to determine the type of hinge arm, the drilling distance "K" and the height of the mounting plate "H" which is necessary to solve each application problem.

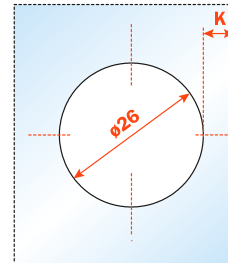

CA sprung hinge

Arm 0

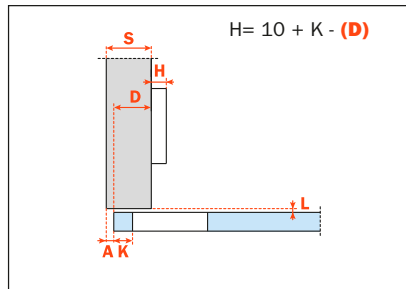

CA - C6C7C39

Arm 9

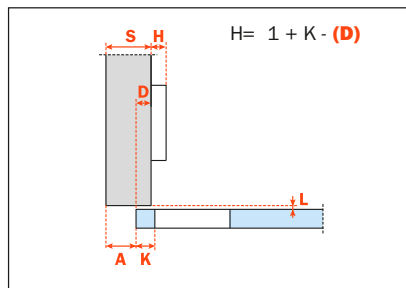

CA - C6C7L39

Arm 17

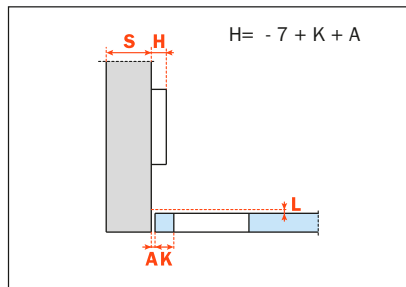

CA - C6C7S39



Technical information

Hinges for doors with positive angled assembly and crampon hinges.

Hole diameter 26 mm.

94° opening.

For use with glass from 4 mm to 6 mm thickness.

Possible drilling distance on the door (K): from 5.5 to 6.5 mm.

Compatible with all traditional Series 200 mounting plates.

NOT COMPATIBLE with Domi snap-on mounting plates.

Packing

Boxes 300 pcs.

Pallets 7.200 pcs.

The solution of assembly problems where doors are mounted at a positive or negative angle requires the verification of drilling distances by a practical trial. Please do not hesitate to consult our technical support department for assistance.

CA sprung hinge

Applications with doors set at any angle between -7.5° to +70° are possible by combining the appropriate hinge and mounting plate.

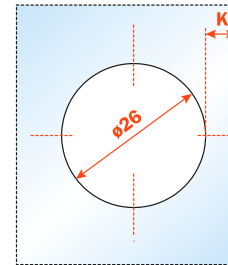

Arm 30°

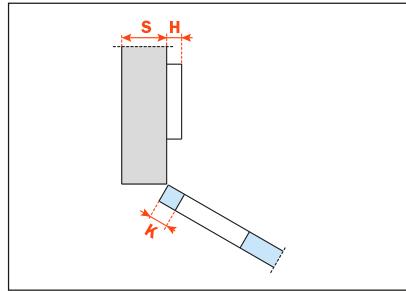

CA - C6C7E39

Arm 45°

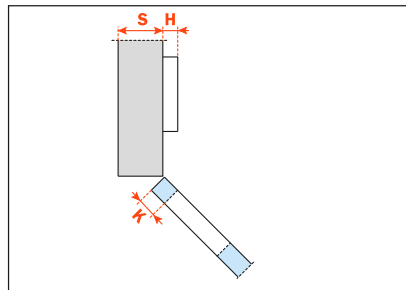

CA - C6C7M39

Crampon

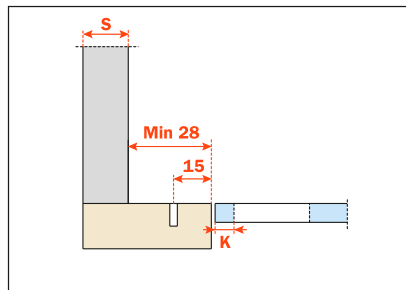

Crampon hinges. To be use only with Series 200 mounting plates for traditional assembly and drilling 28x32 mm.

CA - C6C7N39

Heights of mounting plates for every assembly.

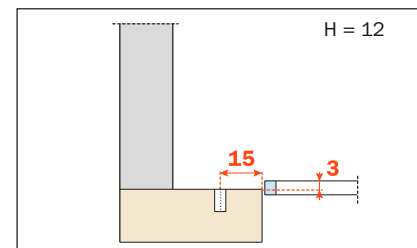
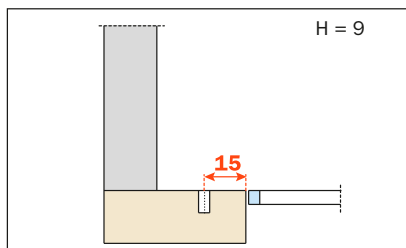
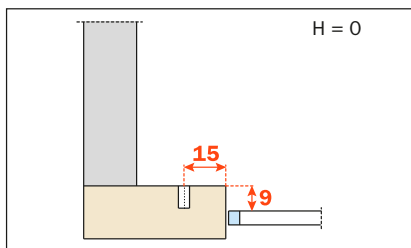

Series B



No drilling of the glass is required.
Bright nickel plated die-cast cup and arm.

Disclaimer

Salice Series B (CBG) hinges have been developed for use on glass doors and mirrors. Salice will accept no responsibility for any problems associated with the type of adhesive or method of application when used in conjunction with Series B hinges, nor for any consequences of the incorrect mounting of the door. It is recommended that the selected adhesive is subjected to prior testing. The adhesive may be considered appropriate if the plate, when fixed to the glass, can sustain a minimum torsion load of 160 Nm.

Constant "L" value of 0.7 mm (it does not change during side adjustment).

Approx. number of hinges required according to the door dimension and weight.

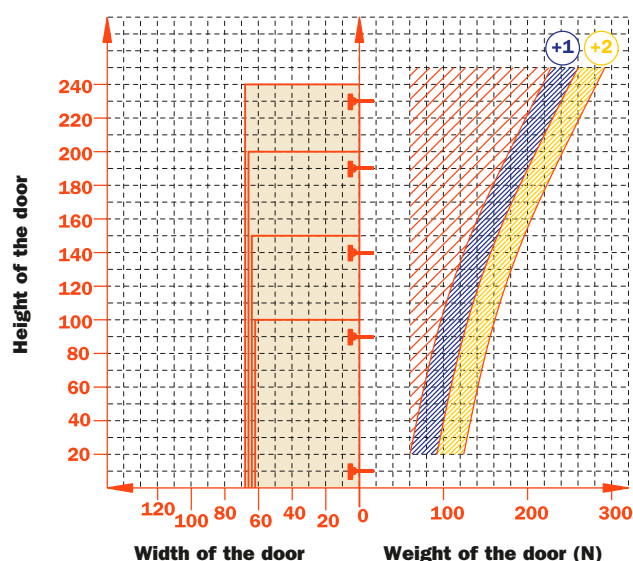

DB01SN_



Must be fixed to Series B hinges to soften the closing action of the door.

For assembly instructions see page 257.



Adjustments

Compensated side adjustment from -1.5 mm to +4.5 mm.
 Height adjustment ± 2 mm.
 Depth adjustment with Series 200 mounting plates +2.8 mm.
 Depth adjustment with Domi snap-on mounting plates from -0.5 mm to +2.8 mm.
 Anti-sliding safety stop.

Mounting plates

Symmetrical and asymmetrical bright nickel plated steel or die-cast Series 200 mounting plates.
 Snap-on assembly on Domi mounting plates.
 Positioning with pre-determined stop on traditional Series 200 mounting plates.

N.B. : Use POZIDRIVE No. 2 screwdrivers for all screws.

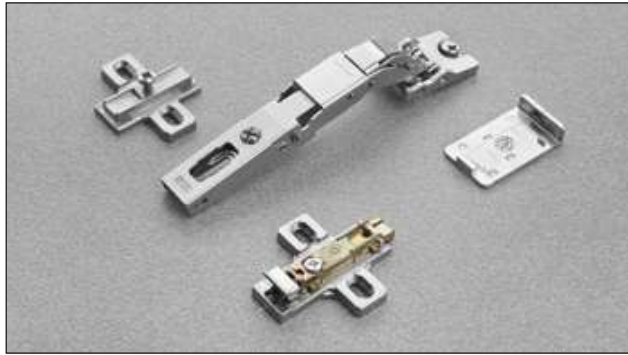

Technical information

Hinge for glass doors. No drilling of the glass is required.
 Possible fixing inset distance on the door (K): from 0 to 22 mm.
 110° opening.
 Compatible with all traditional Series 200 mounting plates and
 with all Domi snap-on mounting plates.

CA sprung hinge

Packing
 Boxes 150 pcs.
 Pallets 3.600 pcs.

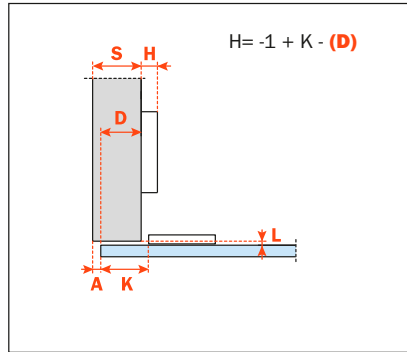
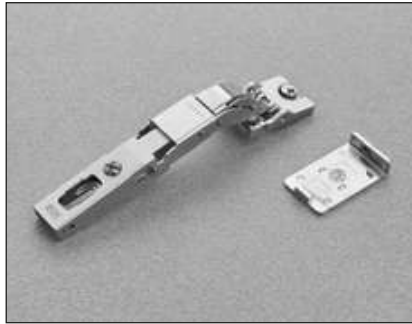

CA - CBG2A99

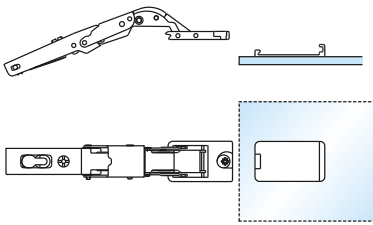

1) The hinge plate must be attached to the glass door or mirror by a special adhesive. We recommend that this operation is carried out by a specialist company. For further information on adhesives and their application, please contact the adhesive manufacturer or your glass supplier.

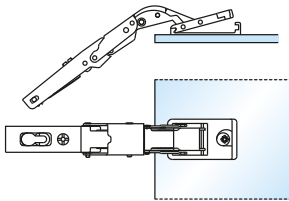

2) Fix the hinge when the plate is bonded to the glass.

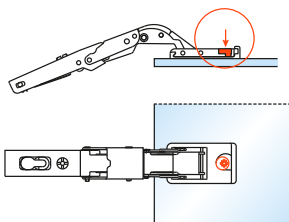

3) Locate the hinge cup onto the plate and rotate the cam.

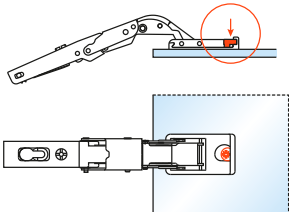

4) The hinge is now fixed to the door.

“C” value

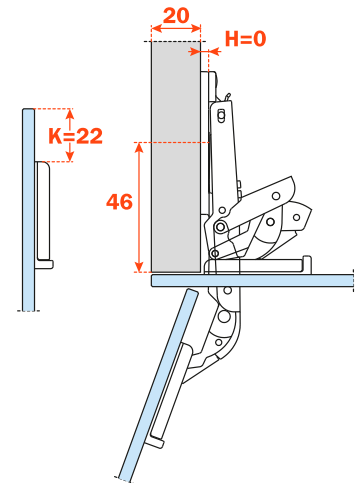

K = 0 - 22

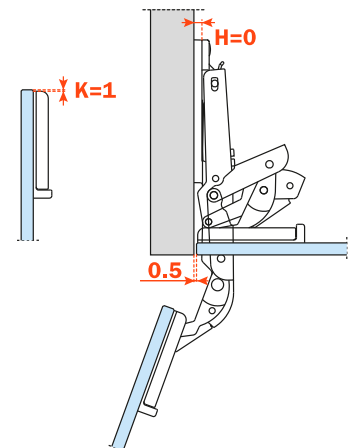

Series B hinges provide a solution to a number of applications that feature moulded edge profiles or half-inlay doors.
Dimensions of the ø35 mm cup.
Bright nickel plated die-cast cup and arm.

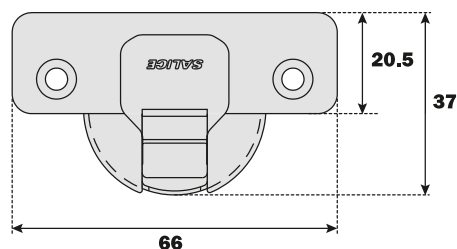

Constant "L" value of 0.7 mm (it does not change during side adjustment).

Approx. number of hinges required according to the door dimension and weight.

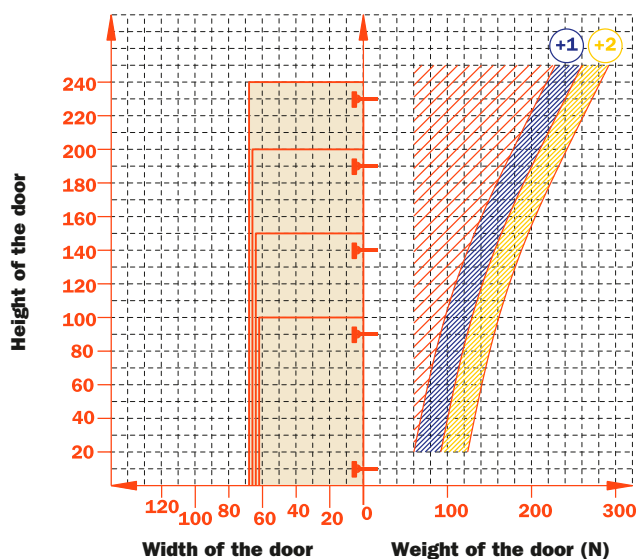

DB01SN_



Smove to be fixed to Series B hinges to soften the closing action of the door.

For assembly instructions see page 257.



Adjustments

Compensated side adjustment from -1.5 mm to +4.5 mm.
 Height adjustment ± 2 mm.
 Depth adjustment with Series 200 mounting plates +2.8 mm.
 Depth adjustment with Domi snap-on mounting plates from -0.5 mm to +2.8 mm.
 Anti-sliding safety stop.

Mounting plates

Symmetrical and asymmetrical bright nickel plated steel or die-cast Series 200 mounting plates.
 Snap-on assembly on Domi mounting plates.
 Positioning with pre-determined stop on traditional Series 200 mounting plates.

N.B. : Use POZIDRIVE No. 2 screwdrivers for all screws.

	<p>48 $\varnothing 35$ 6 110°</p>	<p>45 $\varnothing 35$ 9.5 110°</p>	<p>52 $\varnothing 35$ 5.5 110°</p>
<p>Wood screw</p>	A	P	U
	<p>48 $\varnothing 35$ $\varnothing 10$ 6 110°</p>	<p>45 $\varnothing 35$ $\varnothing 8$ 9.5 110°</p>	<p>52 $\varnothing 35$ $\varnothing 10$ 5.5 110°</p>
<p>Dowel</p>	B	R	W

Use this table to identify the available drillings and fixings.

Fill the third position of the hinge code number with the letter or the number corresponding to your choice. I.e.: CB_2A99.

↑
Fill this position with the chosen letter or number.



Technical information

Series B hinges provide a solution to a number of applications that feature moulded edge profiles or half-inlay doors.

9 mm deep metal cup.
 110° opening.
 Possible drilling distance on the door (K): from 3 to 18 mm.
 Compatible with all traditional Series 200 mounting plates and with all Domi snap-on mounting plates.

Space needed to open the door

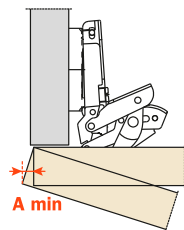

	T=	16	18	20	22	24	26
K=3	A=	0.0	0.0	0.0	0.0	0.3	1.4
K=4	A=	0.0	0.0	0.0	0.0	0.4	1.5
K=5	A=	0.0	0.0	0.0	0.0	0.5	1.9
K=6	A=	0.0	0.0	0.0	0.0	0.7	2.6
K=7	A=	0.0	0.0	0.0	0.0	11.3	12.8
K=8	A=	0.0	0.0	0.0	0.0	10.3	12.9
K=9	A=	0.0	0.0	0.0	0.0	9.3	11.9
K=10	A=	0.0	0.0	0.0	6.0	8.3	10.9
K=11	A=	0.0	0.0	0.0	5.1	7.3	9.9
K=12	A=	0.0	0.0	0.0	4.1	6.3	8.9
K=13	A=	0.0	0.0	1.4	3.3	5.3	7.9
K=14	A=	0.0	0.0	0.7	2.6	4.5	6.9
K=15	A=	0.0	0.0	0.2	2.0	3.8	5.9
K=16	A=	0.0	0.0	0.0	1.4	3.2	5.0
K=17	A=	0.0	0.0	0.0	1.0	2.7	4.4
K=18	A=	0.0	0.0	0.0	0.7	2.2	3.9

The above values are calculated on the assumption that the doors have square edges. They are reduced if the doors have radiussed edges.

Projection of the door

Projection of the door from the cabinet side at the max. opening. The figures are based on a straight arm hinge, H=0 mm thickness of mounting plate and K value = 3 mm.

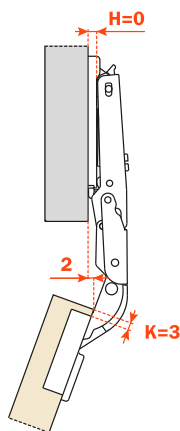

“C” value

With this formula you can obtain the max. thickness of the moulded door that can be opened without touching adjacent carcass sides, doors or walls, whilst bearing in mind the above L-K-T values.

$$C = 5.5 + K + A$$

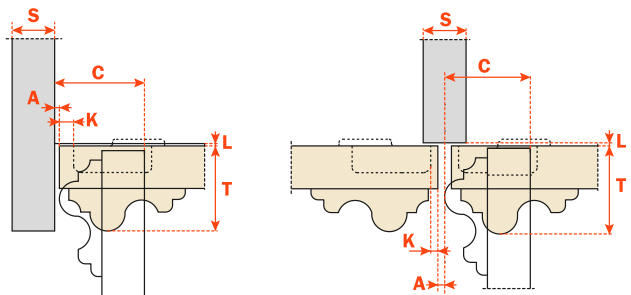

Packing

Boxes 150 pcs.
Pallets 3.600 pcs.

CA sprung hinge

Use these formulas to determine the type of hinge arm, the drilling distance "K" and the height of the mounting plate "H" which is necessary to solve each application problem.

To limit the opening of the hinge, see page 354 chapter "Accessories".

Use the tables "Drillings and fixings" at page 171 to complete the code number of the desired hinge.

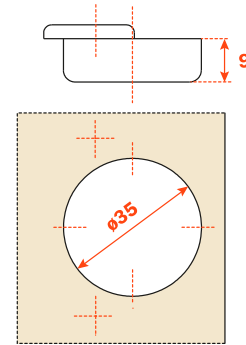

Arm 0

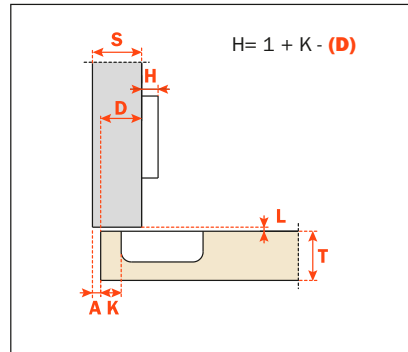
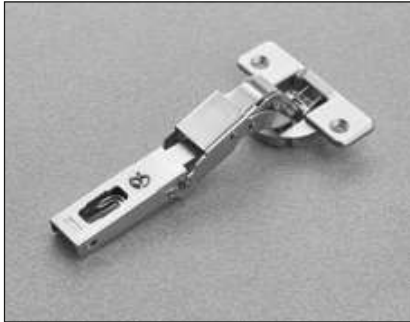

CA - CB_2A99

Series B - For wooden doors - assembly examples

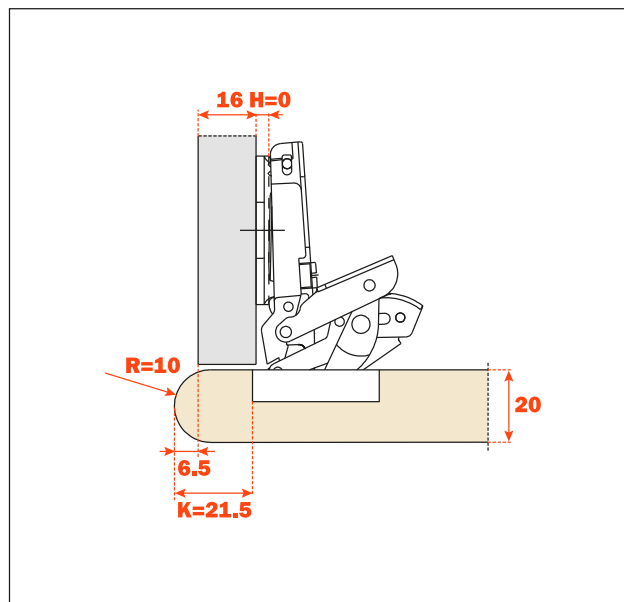
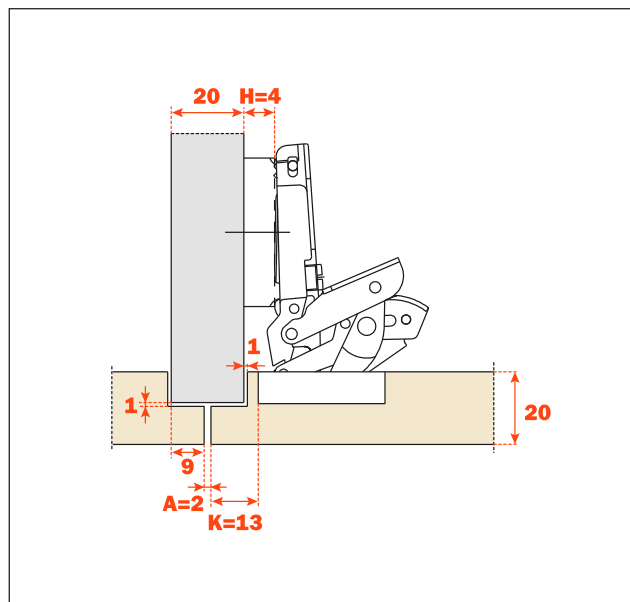
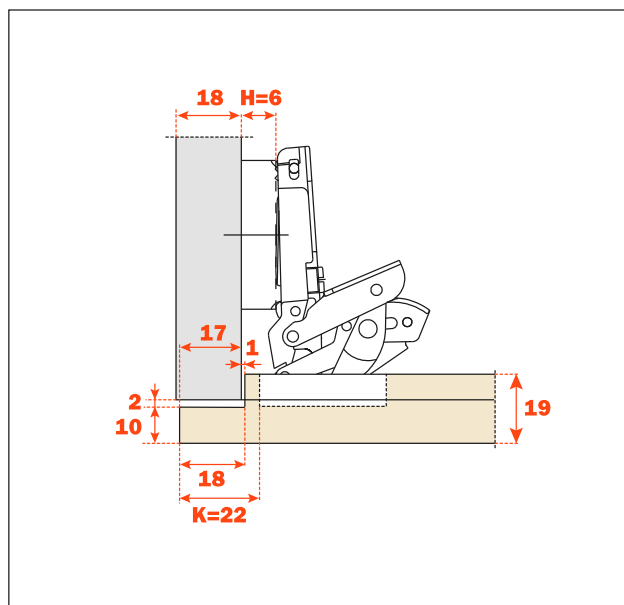
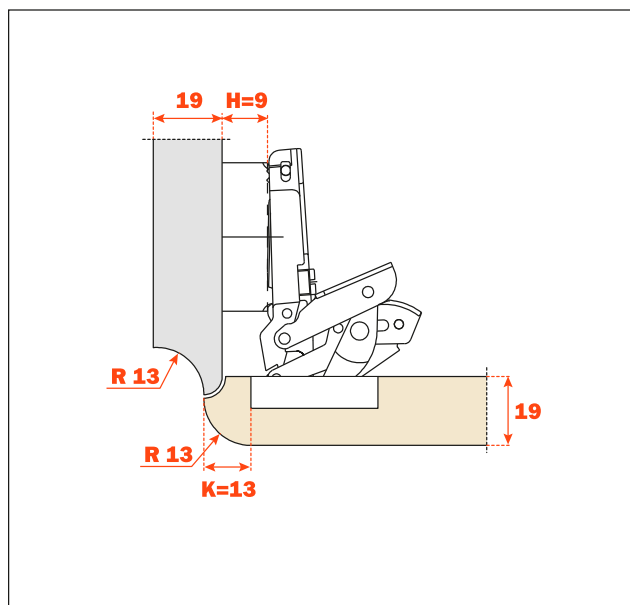
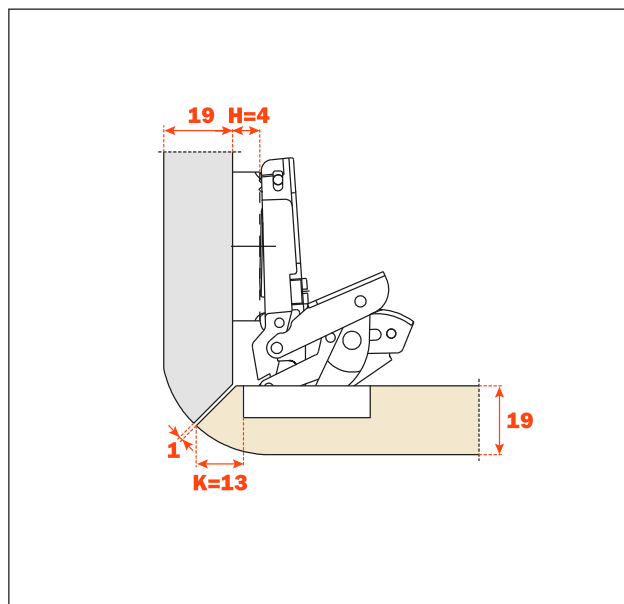
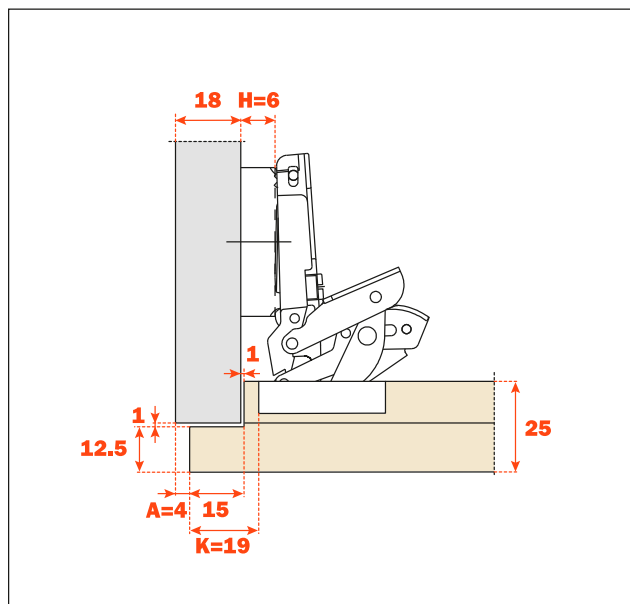

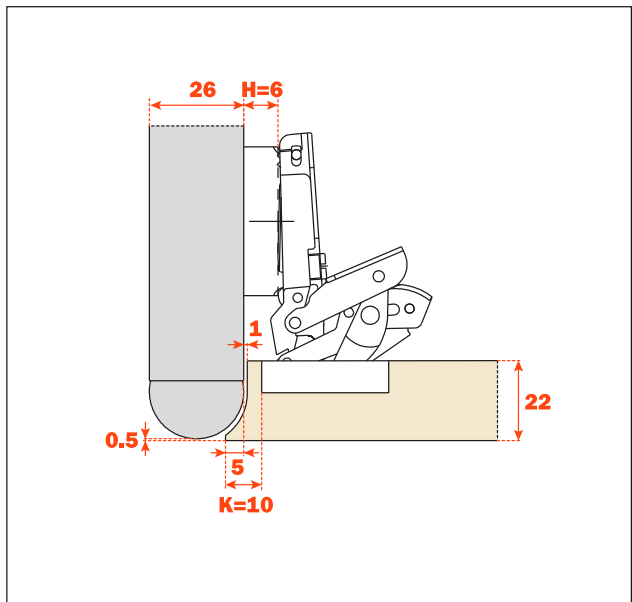
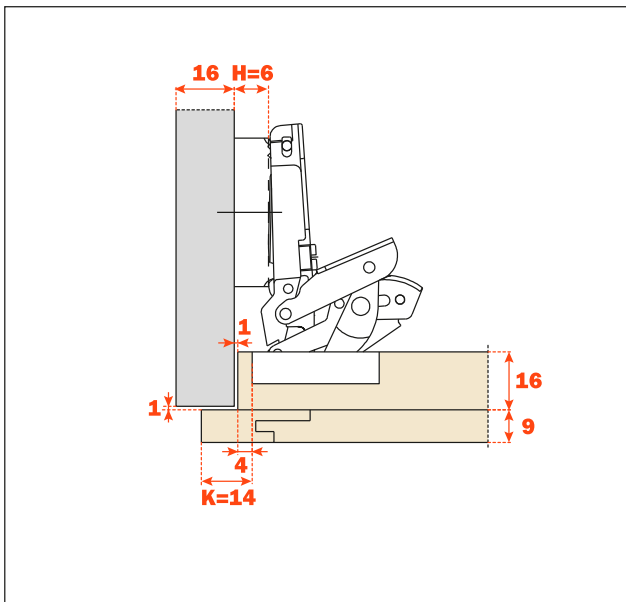
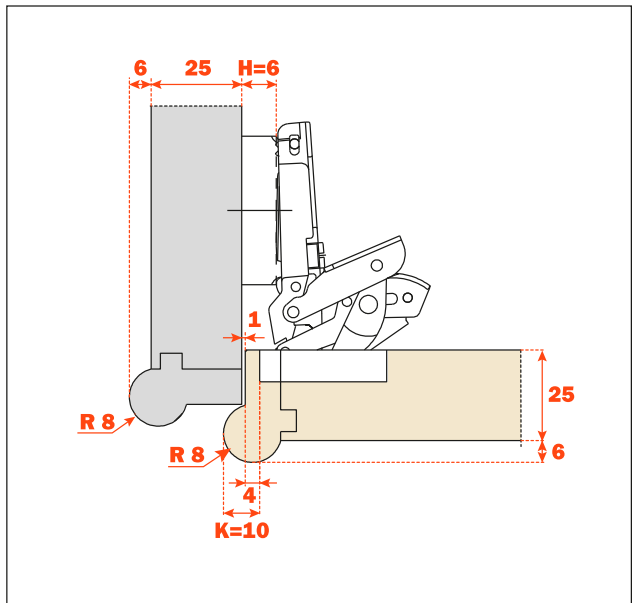
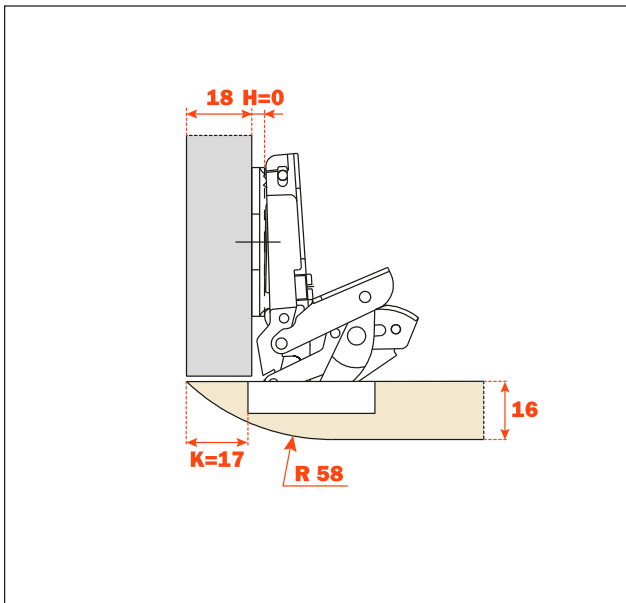
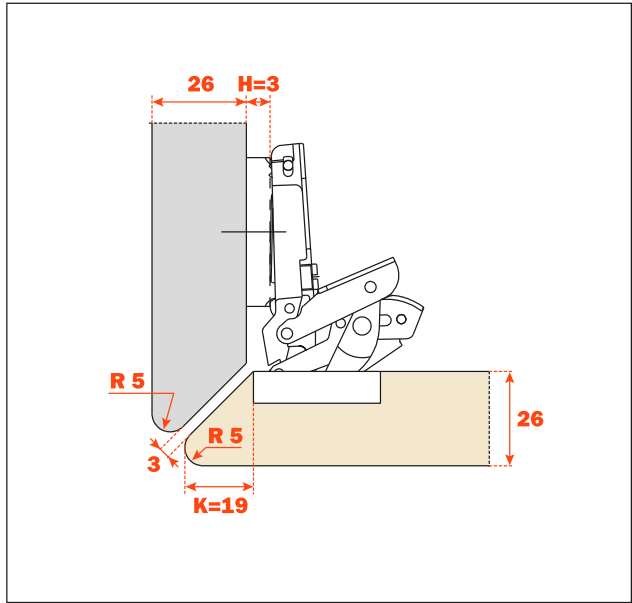
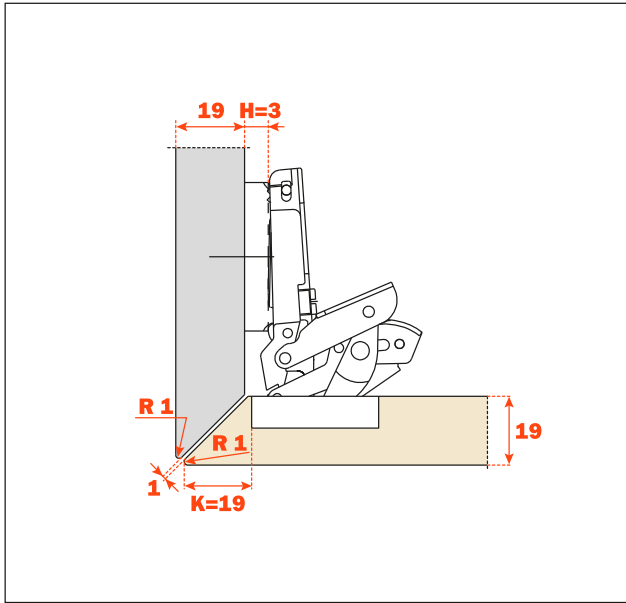

Series M

Series M



Bright nickel plated die-cast cup and arm.
Sprung hinge (with spring).

Ideal for the most critical applications, where high stability, strength and endurance are required. They are certified for applications in public environments in conformity with FIRA Level 5 and ANSI Grade 1 requirements.

Adjustments

Compensating side adjustment from -3 mm to +3 mm.
With mounting plates H=0 the negative side adjustment cannot be used.
Height adjustment ±2 mm.
Depth adjustment with Series 200 mounting plates +2.8 mm.
Depth adjustment with Domi snap-on mounting plates from -0,5 mm to +2.8 mm.
Anti-sliding safety stop.

Mounting plates

Symmetrical and asymmetrical bright nickel plated steel or die-cast Series 200 mounting plates.
Snap-on assembly on Domi mounting plates.
Positioning with pre-determined stop on traditional Series 200 mounting plates.
N.B. : Use POZIDRIVE No. 2 screwdrivers for all screws.

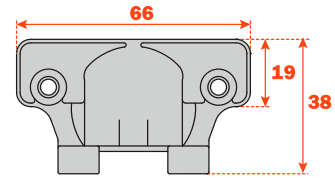

Drillings and fixings

	<p>48 6 ø 35 270°</p>	<p>45 9.5 ø 35 270°</p>	<p>52 5.5 ø 35 270°</p>
<p>Wood screw</p>	A	P	U
	<p>48 6 ø 35 ø 10 270°</p>	<p>45 9.5 ø 35 ø 8 270°</p>	<p>52 5.5 ø 35 ø 10 270°</p>
<p>Dowel</p>	B	R	W

Use this table to identify the available drillings and fixings. Fill the third position of the hinge code number with the letter or the number corresponding to your choice. I.e.: CM_3A99.



Fill this position with the chosen letter or number.



Use the tables "Drillings and fixings" at page 176 to complete the code number of the desired hinge.

Use these formulas to determine the height of the mounting plate "H" which is necessary to solve each application problem.

CM_3A99

Packing

Boxes 100 pcs.
Pallets 2.400 pcs.

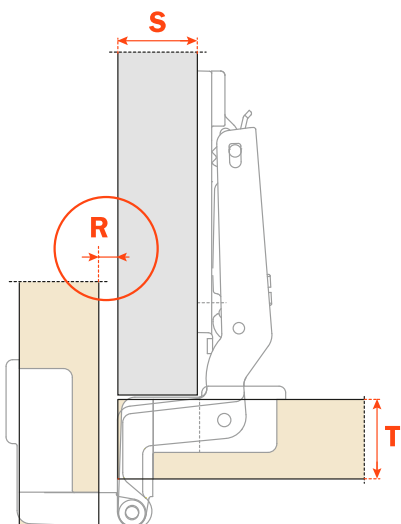
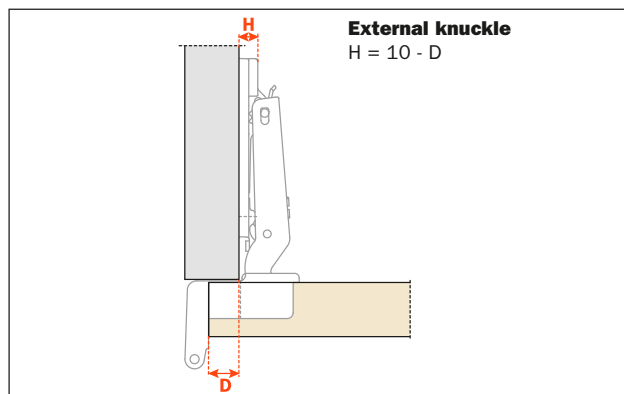
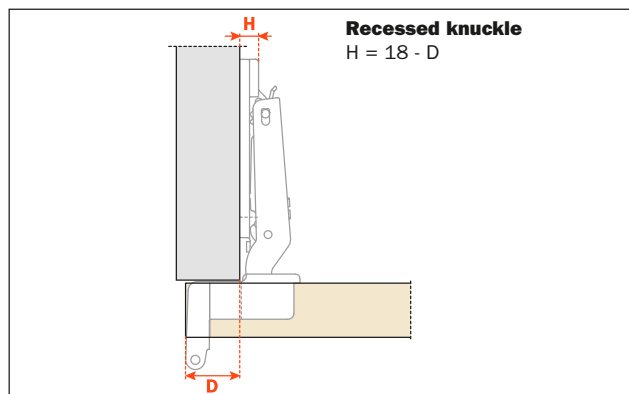
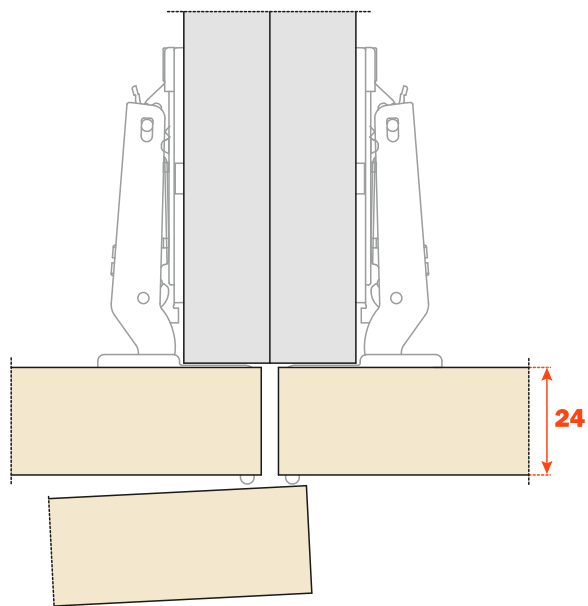

Chart to verify that full 270° opening is possible.
Full 270° opening is possible only with R value ≥ 0 and mounting plates H=0 mm.
Otherwise the actual opening must be checked with a practical test.

		Door thickness T		
Side thickness S		18	19	20
	20	2,25	1,25	0,25
	19	3,25	2,25	1,25
	18	4,25	3,25	2,25
R value				



180° opening with door thickness max. 24 mm.

Application with recessed knuckle

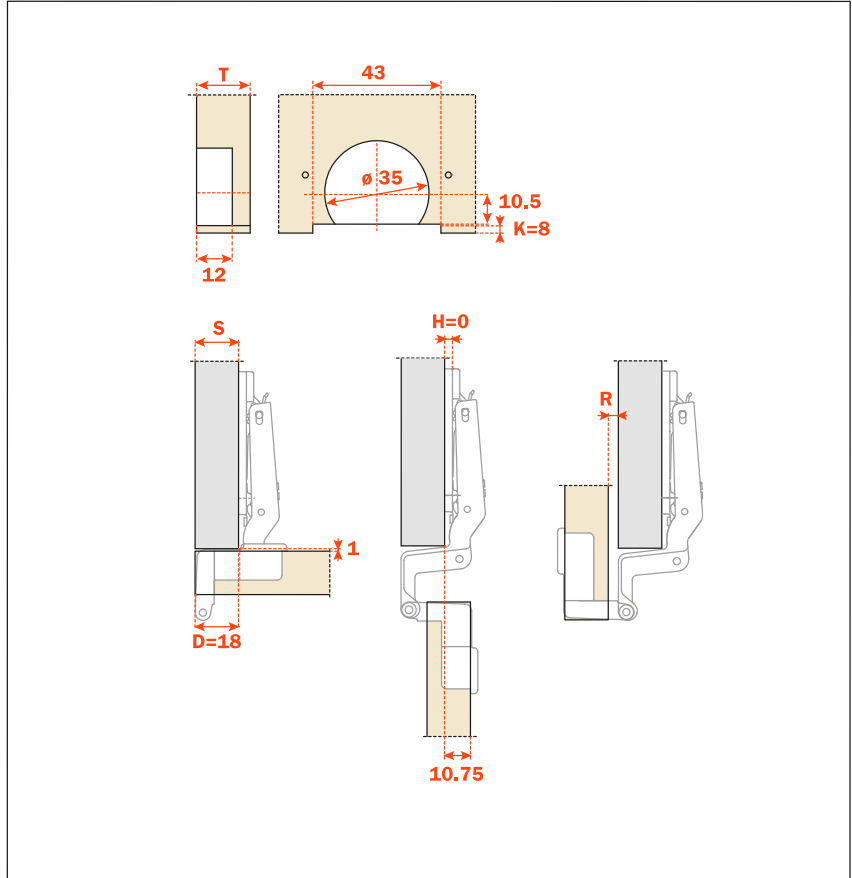

Application with external knuckle

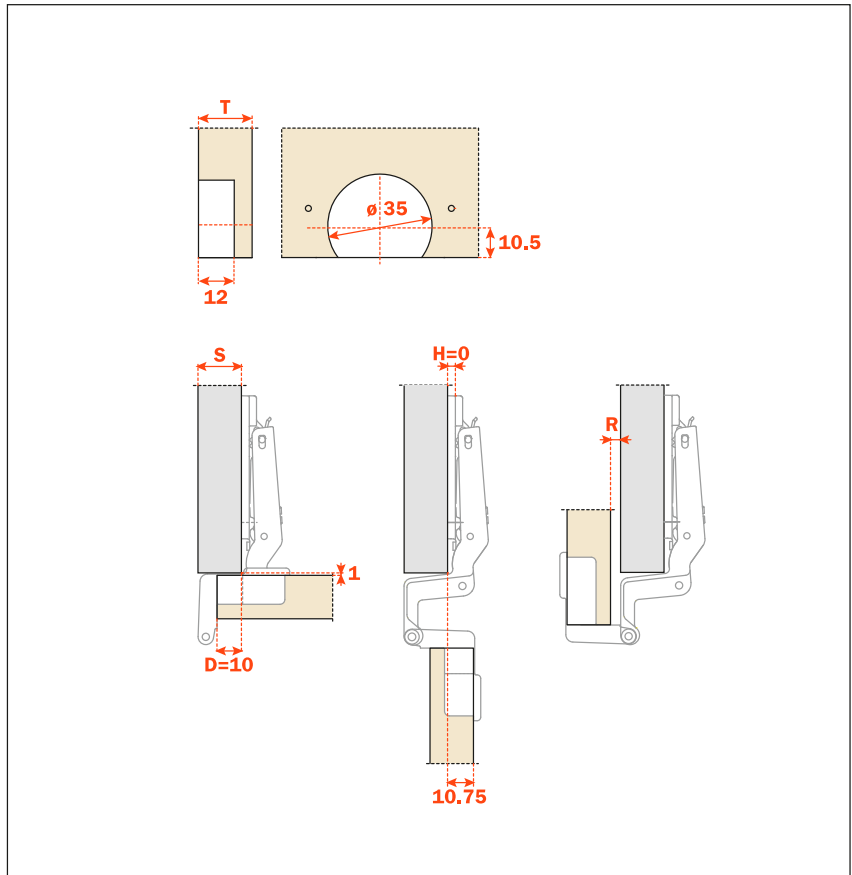

Application with inset door

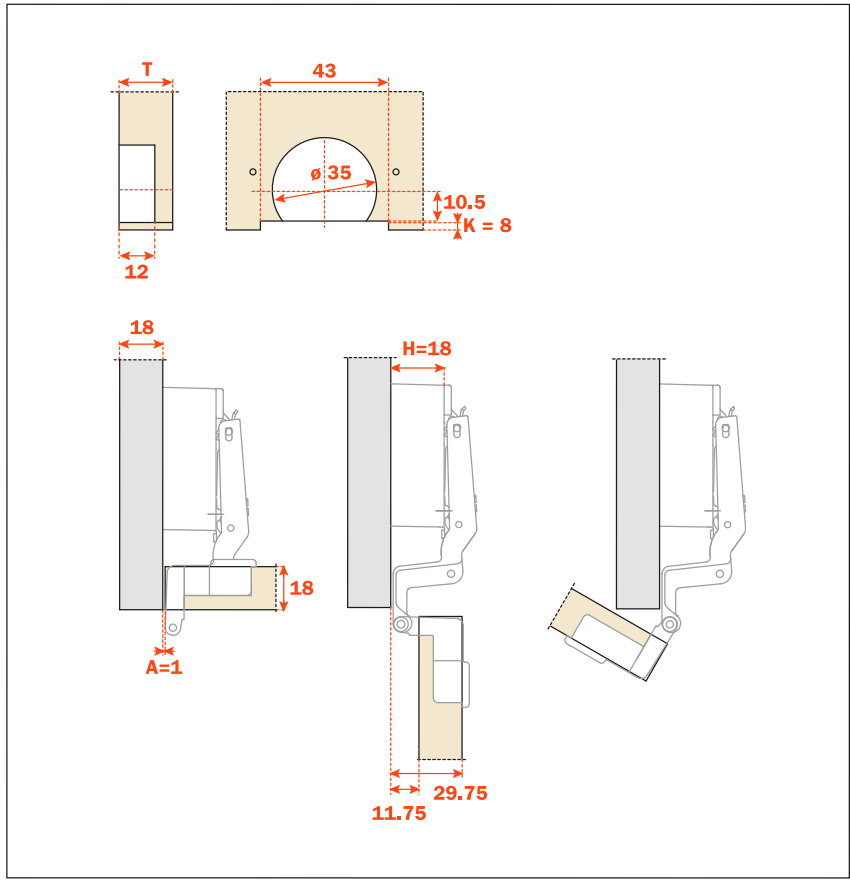

Application with half overlay door

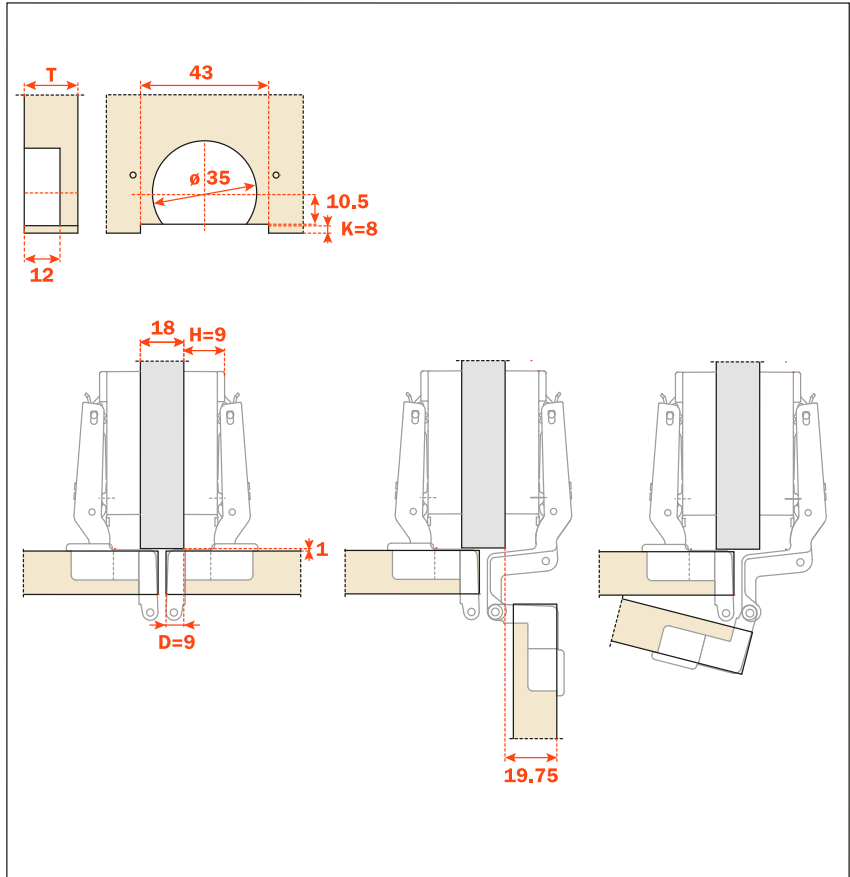

Mechanical Push



Mechanical Push

Mechanical Push

The PUSH-System is a self-opening system for the doors of all types of handleless furniture.

It consists of a series of self-opening hinges, release devices that can be fitted to the top, base or side panel of the cabinet, and retaining catches to be fitted to the back of the door.

The retaining catches can be pressure-fixed or screw-fixed.

For doors over 1600 mm in height, we suggest that you use two mechanical release catches.



DP1SNB - beige



DP1SNG - grey



With assembly stop device

Packing
Boxes 300 pcs.

Installation of mechanical Push with adhesive strip

For correct application and to ensure optimal endurance, please follow the following procedure:

- 1)** clean and degrease the cabinet surface where the release device is to be installed using an acetone based cleaner;
- 2)** remove the protective strip from the adhesive;
- 3)** place the release device in position and apply a firm pressure for about one minute;
- 4)** allow a period of 12 hours to elapse before subjecting the PUSH-System to continuous usage.



Mechanical Push - Release device to be screw-fixed

DP3SNB - beige



DP3SNG - grey



With assembly stop device

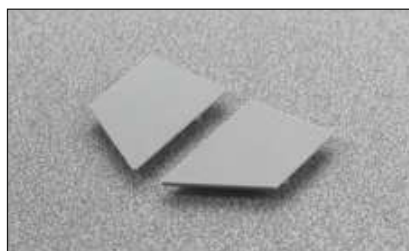

Packing

Boxes 300 pcs.

DP3SNBR - beige



DP3SNGR - grey



Without assembly stop device

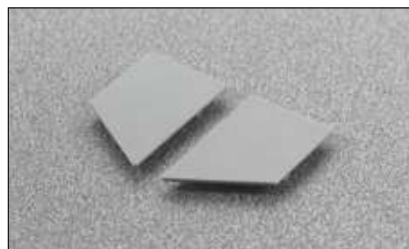

Packing

Boxes 300 pcs.

DP4SNB - beige

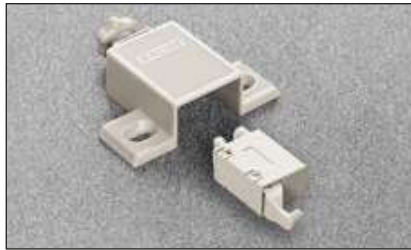

DP4SNG - grey

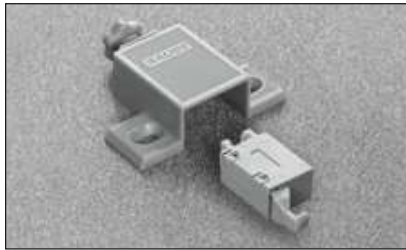

Single adapter with depth and sideways adjustment and release device. Without assembly stop device.

Packing

Boxes 300 pcs.

DP5SNB - beige



DP5SNG - grey

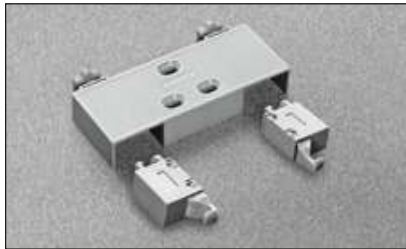

Double adapter with depth and sideways adjustment and release devices. Without assembly stop device.

Packing

Boxes 150 pcs.

N.B.: Drilling patterns at page 190

Technical information on the adjustable mechanical Push

The adjustable Push consists of a release device and a screw-fixed adapter which have been developed to improve the locating action of the system.

The adjustable Push now has a depth adjustment facility with a range of -1 mm to + 2.5 mm which is controlled by a small adjuster wheel located at the back of the adapter.

In addition, the adapter has a sideways adjustment facility of ± 2 mm. This is achieved by loosening the two fixing screws and adjusting the position of the adapter using the elongated holes. Finally, the screws must be retightened.



Mechanical Push - Retaining catches for wooden doors

DP29SNB - beige



DP29SNG - grey



Retaining catch for wooden door.
Knock-in.

Packing
Boxes 300 pcs.

DP29SNBMC - beige



DP29SNGMC - grey



Retaining catch for wooden door and special assemblies.
Knock-in.

Packing
Boxes 300 pcs.

DP29SNBI - beige



DP29SNGI - grey

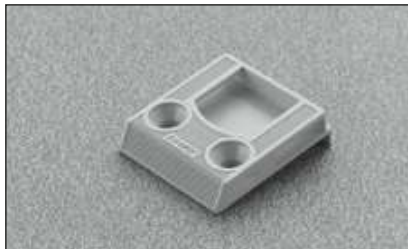

Retaining catch for wooden door.
With assembly stop device.
Screw-on.

Packing
Boxes 300 pcs.

DP29SNBR - beige



DP29SNGR - grey

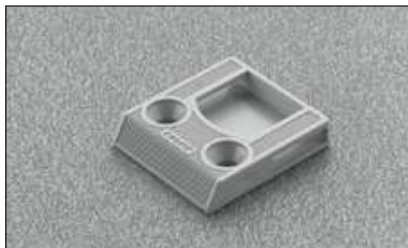

Retaining catch for wooden door.
Without assembly stop device.
Screw-on.

Packing
Boxes 300 pcs.

N.B.: Drilling patterns at page 191

DP29SNBA - beige



DP29SNGA - grey



Retaining catch for aluminium-frame door
width = 35 - 45 mm.

Packing
Boxes 300 pcs.

DP29SNBB - beige



DP29SNGB - grey



Retaining catch for aluminium-frame door
width = 17 - 35 mm.

Packing
Boxes 300 pcs.

DP29SNBP - beige



DP29SNGP - grey



Retaining catch for aluminium-frame door
Practical.

Packing
Boxes 300 pcs.

N.B.: Drilling patterns at pages 192 and 193

DP52SNB - beige



DP52SNG - grey



Single adapter.
6x40 mm drilling.
With assembly stop device.
DP53SN_ = single adapter with sideways adjustment.

Packing
Boxes 300 pcs.

DP52SNBR - beige



DP52SNGR - grey



Single adapter.
6x40 mm drilling.
Without assembly stop device.
DP53SN_R = single adapter with sideways adjustment.

Packing
Boxes 300 pcs.

DP54SNB - beige



DP54SNG - grey



Double adapter.
6x16 mm drilling.
With assembly stop device.

Packing
Boxes 150 pcs.

DP54SNBR - beige



DP54SNGR - grey

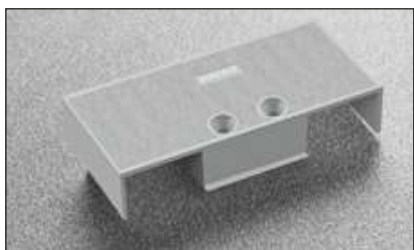

Double adapter.
6x16 mm drilling.
Without assembly stop device.

Packing
Boxes 150 pcs.

DP44XXBD - beige



DP44XXGD - grey

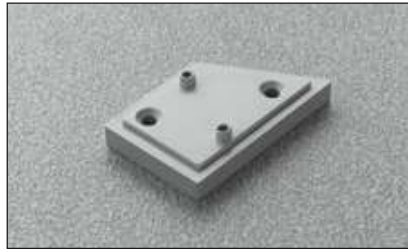

Right spacer H = 4.8 mm.

Packing
Boxes 300 pcs.

DP44XXBS - beige



DP44XXGS - grey

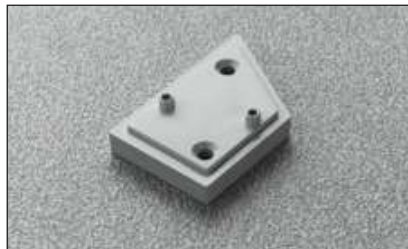

Left spacer H = 4.8 mm.

Packing
Boxes 300 pcs.

DP50SN0



Orange insertion tool for retaining catch DP29SN_.



Push with depth and sideways adjustment

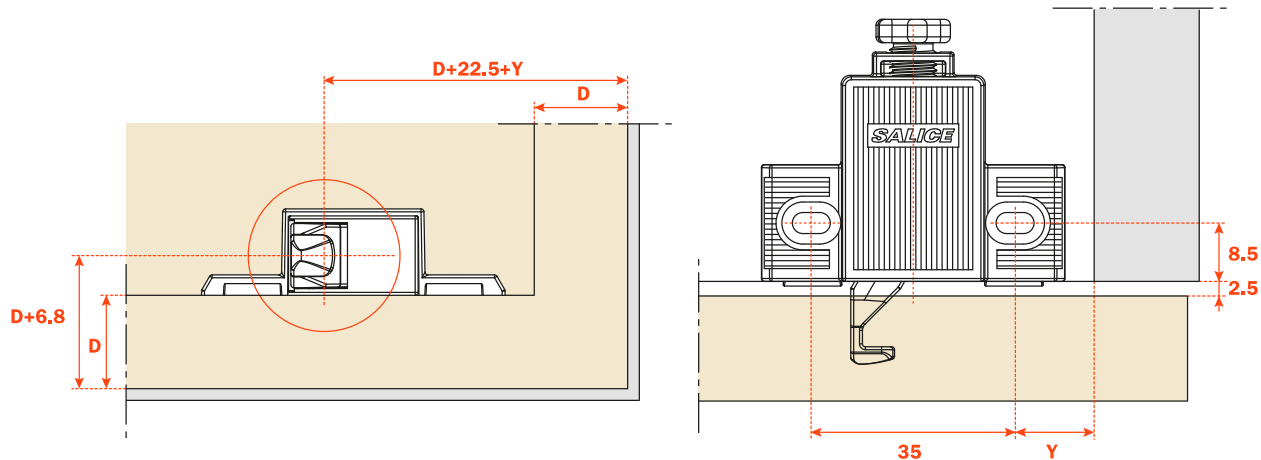

D = Door overlay on side and top of the cabinet
Y = min. 8.5 mm

Double Push with depth and sideways adjustment

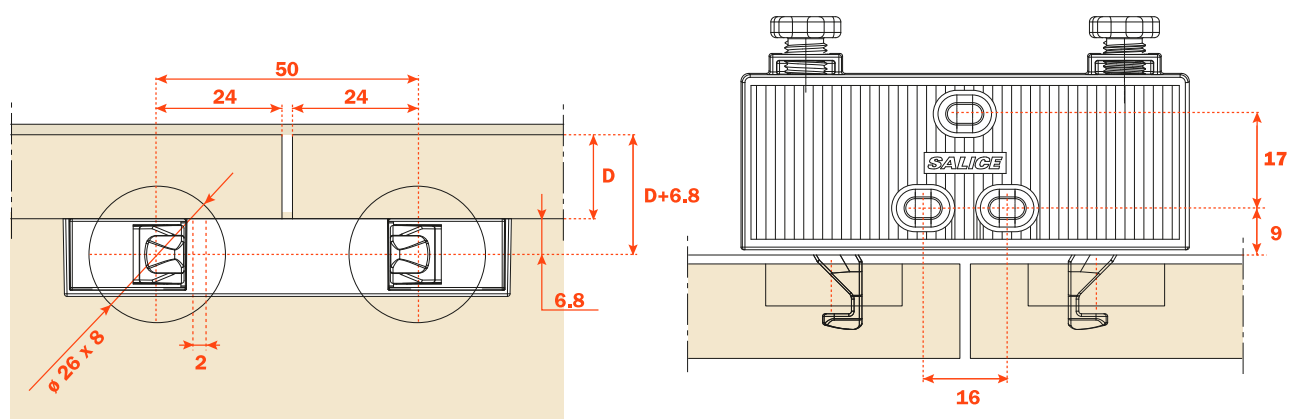

Fulloverlay door

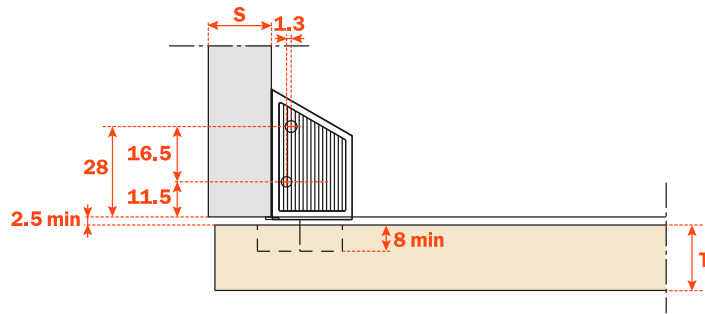
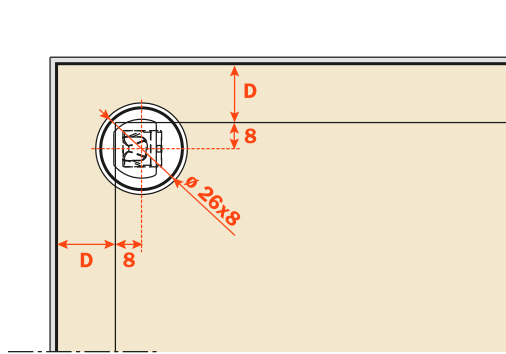

D = Door overlay on side and top of the cabinet
Drilling distance of retaining catch = D + 8

Special assemblies

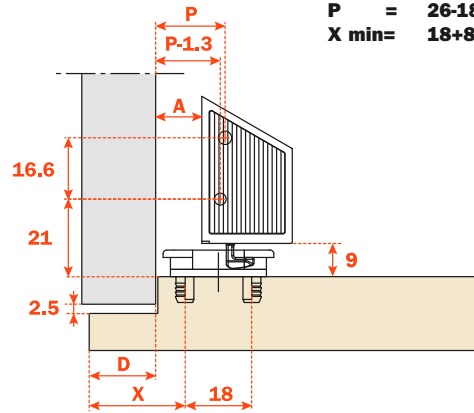
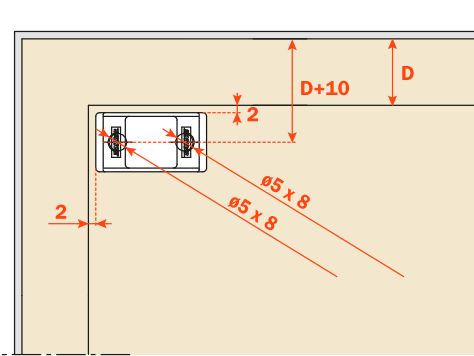

$$\begin{aligned}
 A &= X-D+4.5 \\
 P &= X-D+10.8 \\
 X \text{ min} &= D+8 \\
 \\
 A &= 26-18+4.5 = 12.5 \\
 P &= 26-18+10.8 = 18.8 \\
 X \text{ min} &= 18+8 = 26
 \end{aligned}$$

D = Door overlay on side and top of the cabinet

Inset door

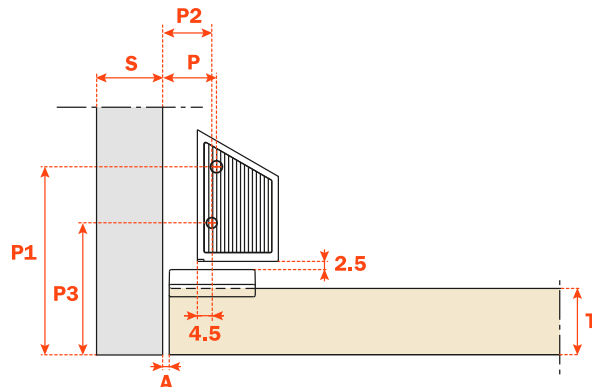
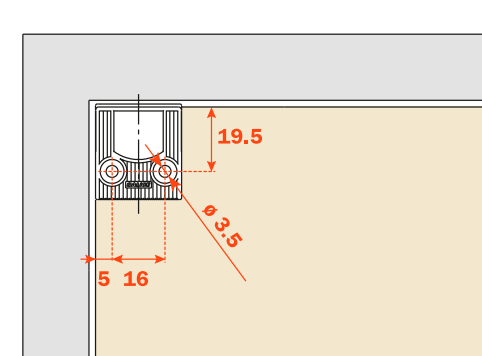

$$\begin{aligned}
 P &= 14.8 + A \\
 P1 &= 36.8 + T \\
 P2 &= P - 1.3 \\
 P3 &= P1 - 16.5
 \end{aligned}$$

Mechanical Push - Drilling for aluminium frame doors

Profile min. 17 mm/max 35 mm

- D** = Door overlay on side and top of the cabinet
- F** = Drilling distance of retaining catch = $D + 8$
- X** = Relative to the distance to the corner of the profile
- P** = Fixing distance of PUSH = $X - D + 1.3$

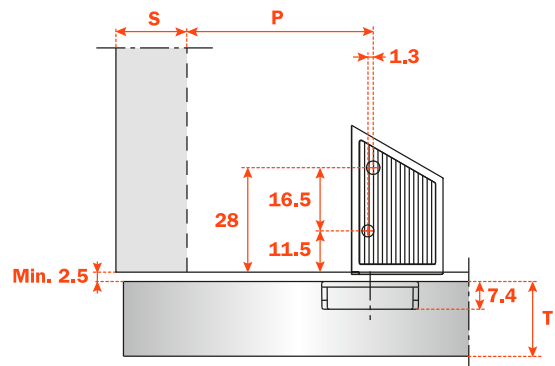
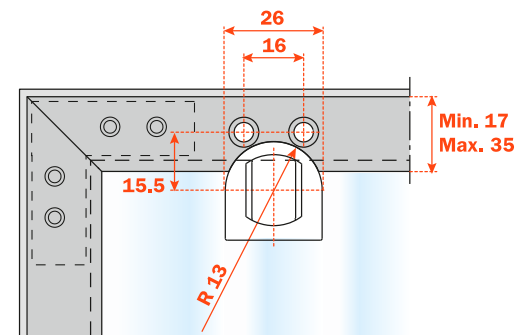
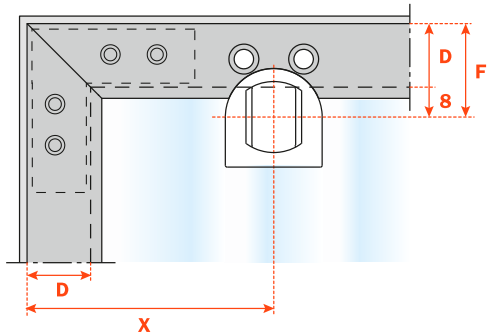

Profile min. 35 mm/max. 45 mm

- D** = Door overlay on side and top of the cabinet
- F** = Drilling distance of retaining catch = $D + 8$
- X** = Relative to the distance to the corner of the profile
- P** = Fixing distance of PUSH = $X - D + 1.3$

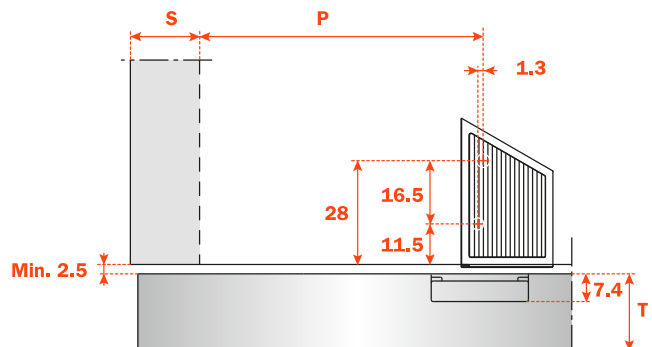
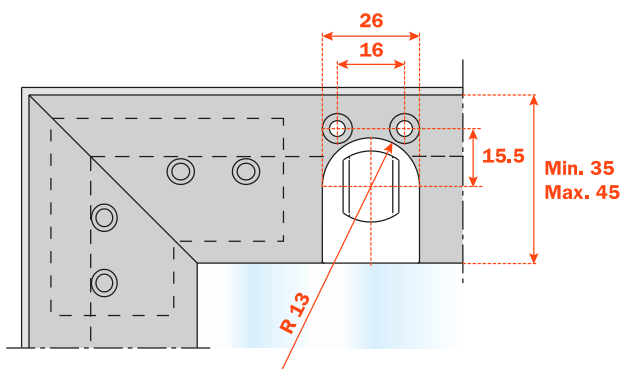
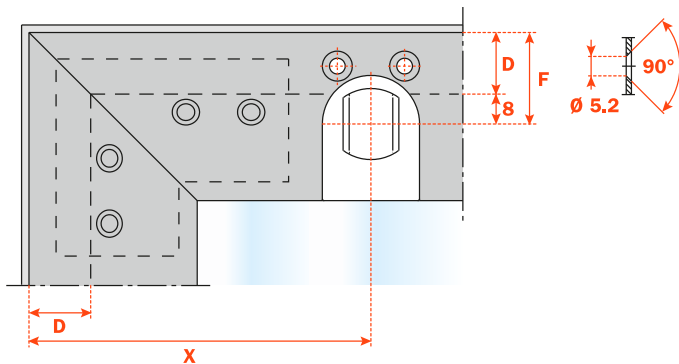

Profile with corner connector D206BS5

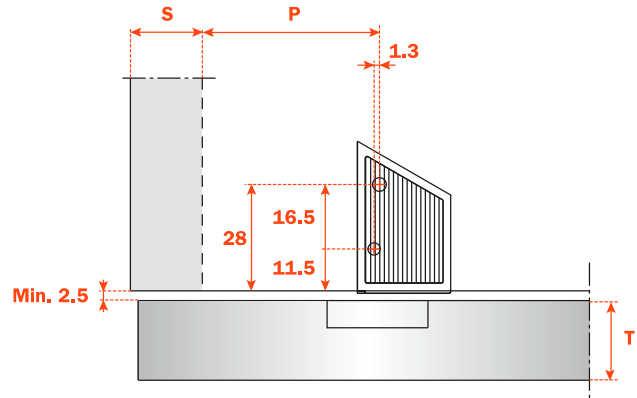
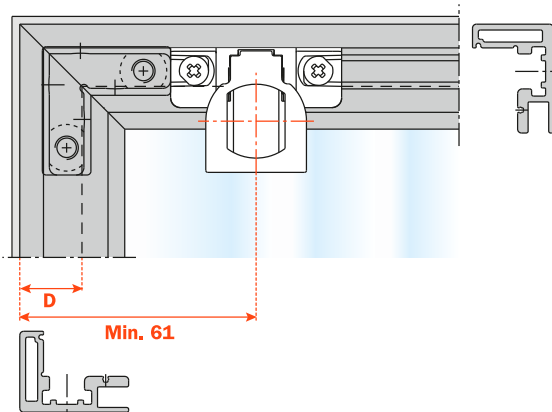

- D = Door overlay on side and top of the cabinet**
- P = Fixing distance of PUSH = 61 (min) - D + 1.3**

Profile with corner connector D206BS5L

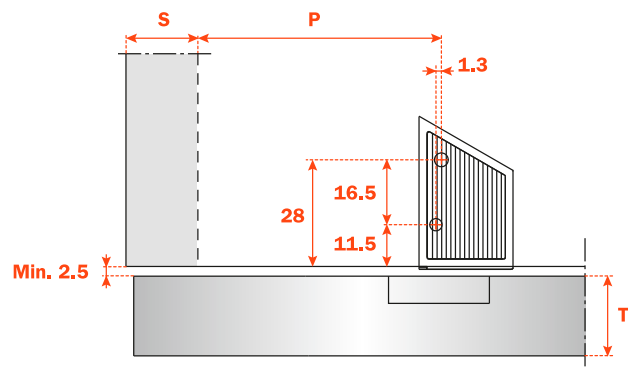
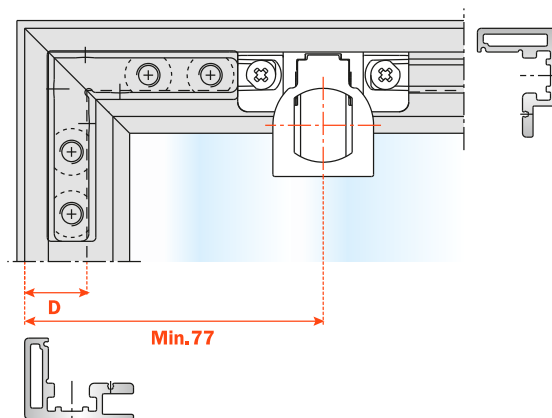

- D = Door overlay on side and top of the cabinet**
- P = Fixing distance of PUSH = 77 (min) - D + 1.3**

Magnetic Push



Magnetic Push

Magnetic Push - Release device to be recessed and retaining catches

DPMSNB - beige



DPMSNG - grey



Release device.
ø 10 mm, 40 mm length.

Packing

Boxes 250 pcs.
Cartons 1.500 pcs.

DPASNB - beige



DPASNG - grey



Release device to be used to increase the magnetic holding strength. It must always be used together with the DPM. The suggested position of the DPM is the point of pressure on the door. The DPA can be positioned at any point along the opening edge of the door. ø 10 mm, 40 mm length.

Packing

Boxes 250 pcs.
Cartons 1.500 pcs.

DP28SN9



Retaining catch to be inserted.
ø 11.5 mm.

Packing

Boxes 250 pcs.

DP38XX91



Retaining catch with adhesive.
20x14 mm.

Packing

Boxes 250 pcs.

DP39XXG

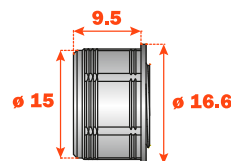

Adjustable magnetic retaining.
ø16.6 mm

Packing

Boxes 250 pcs.

SP44XX_

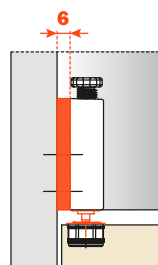

Spacer for inset door to be used together with DP82XX_R.

SP44XXG = grey
SP44XXB = beige

Packing

Boxes 250 pcs.

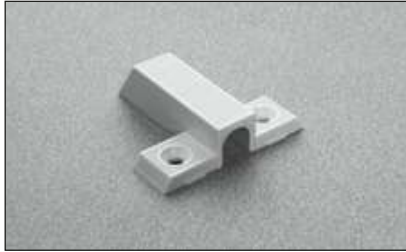
DP80SNBR - beige**DP80SNGR** - grey

Plastic adapter for release device.
To be fixed with wood screws.
7.5x32 mm drilling.
Without assembly stop devices.
DP81SN_R = To be fixed with Euro screws.

Packing

Boxes 500 pcs.
Pallets 12.000 pcs.

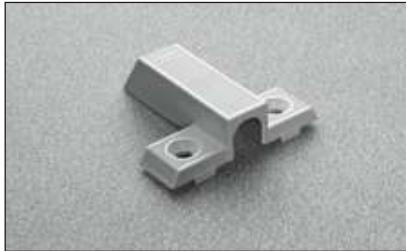
DP80SNB - beige**DP80SNG** - grey

Plastic adapter for release device.
To be fixed with wood screws.
7.5x32 mm drilling.
With assembly stop devices.
DP81SN_ = To be fixed with Euro screws.

Packing

Boxes 500 pcs.
Pallets 12.000 pcs.

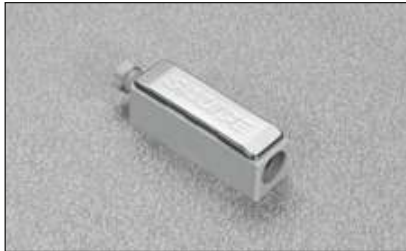
DP82XXBR - beige**DP82XXGR** - grey

Adjustable longitudinal plastic adapter
for release device.
To be fixed with wood screws.
8+16 mm drilling.
Without assembly stop devices.

Caps to be ordered separately.

Packing

Boxes 500 pcs.
Pallets 12.000 pcs.

DP83XXBR - beige**DP83XXGR** - grey

Adjustable double plastic adapter for
release device.
To be fixed with wood screws.
8+32 mm drilling.
Without assembly stop devices.

Cover caps to be ordered separately.

Packing

Boxes 500 pcs.
Pallets 12.000 pcs.

DP84SNBR - beige**DP84SNGR** - grey

Adjustable plastic adapter for release device.
To be fixed with wood screws.
8x32 mm drilling.
Without assembly stop devices.

Packing

Boxes 500 pcs.
Pallets 12.000 pcs.

DP85SNBR - beige**DP85SNGR** - grey

Adjustable plastic adapter for release device.
To be fixed with wood screws.
37x32 mm drilling.
Without assembly stop devices.

Packing

Boxes 500 pcs.
Pallets 12.000 pcs.

Application of the release device to be recessed

Drill a hole \varnothing 10 mm and min. 40 mm depth in the top, the side or the base panel of the cabinet.
Insert the release device into the hole.

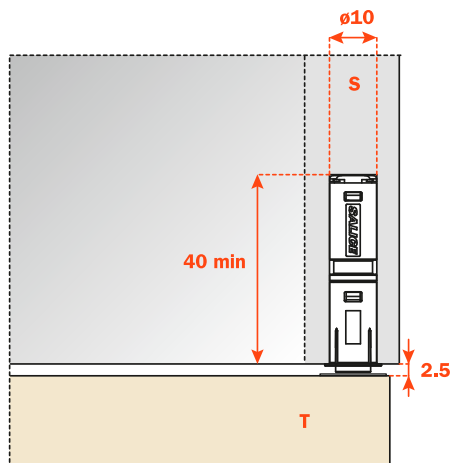

Release device application with adapter (DP82SN_R).

Insert the release device frontally into the adapter.
Place the adapter to the top, the side or the base panel of the cabinet, using the drilling value of 8+16 mm for final positioning.

For inset door it is essential to use the spacer SP44XX_.

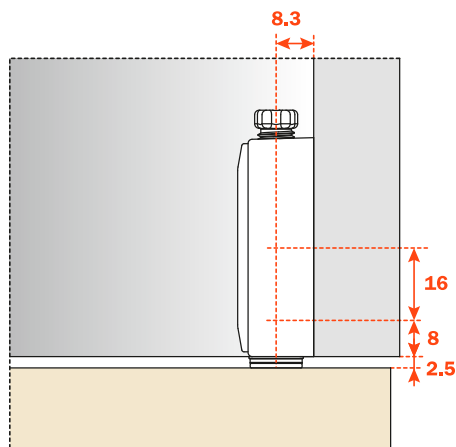

Release device application with spacer for inset door (DP82SN_R + SP44XX_).

For inset door it is essential to use the spacer SP44XX_.

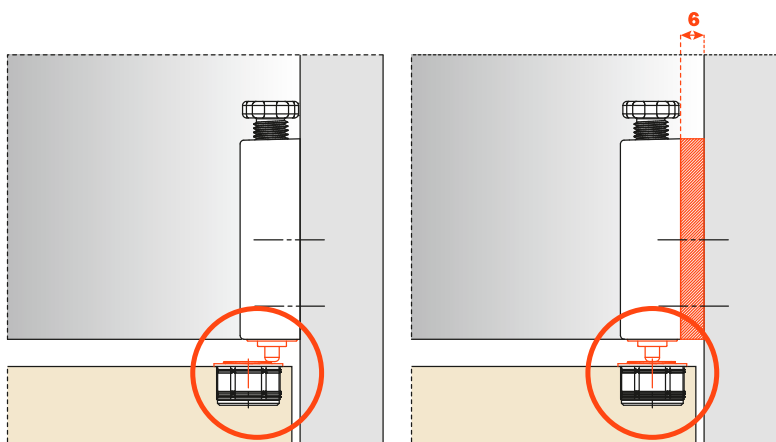

Release device application with adapter (DP83XX_R).

Insert the release device frontally into the adapter.
Place the adapter to the top, the side or the base panel of the cabinet, using the drilling value of 8+32 mm for final positioning.

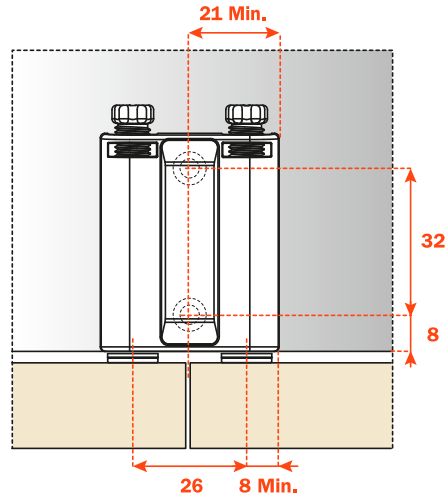

Release device application with adapter (DP80SN_ and DP84SN_R).

Insert the release device into the adapter.
Place the adapter to the top, the side or base panel of the cabinet, using the drilling value of 8x32 mm for final positioning.

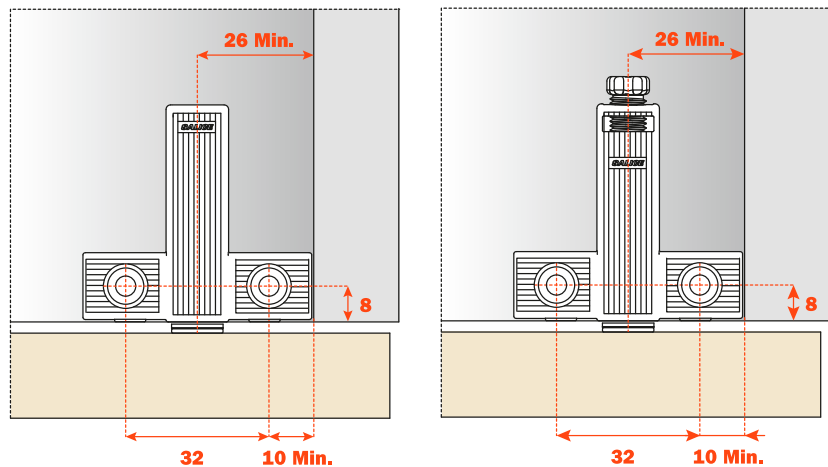

Release device application with adapter (DP85SN_R).

Insert the release device into the adapter.
Place the adapter to the top, the side or base panel of the cabinet, using the drilling value of 37x32 mm for final positioning.

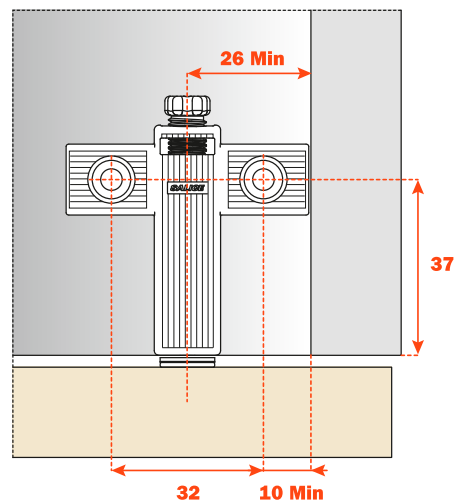

1 - Retaining catch with adhesive strip

Apply the retaining catch to the magnetic release device.
Remove the protective strip from the adhesive.
Close the door.
In this way the retaining catch is positioned on the door.
Reopen the door and apply a firm pressure to the retaining catch to ensure a correct installation.

ATTENTION:

For a correct application and to ensure optimal endurance, we suggest these guidelines are followed:

- 1 - clean and degrease the door surface where the retaining catch is to be installed;
- 2 - remove the protective strip from the adhesive;
- 3 - place the retaining catch in position, in a place that is at room temperature $\geq 10^{\circ}$ and apply a firm pressure for 10-15 seconds.

After few seconds from the installation the retaining catch is suitable for the use. After 24h the max. hold is attained.

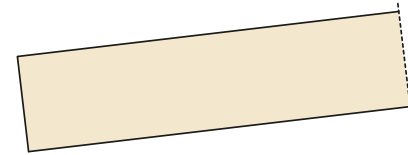
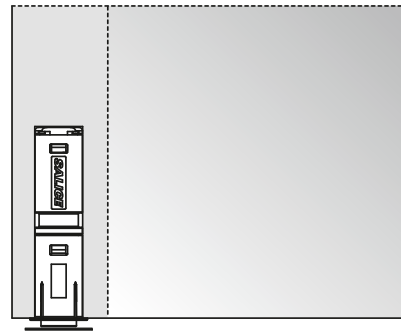

2 - Retaining catch to be inserted

Apply the retaining catch to the magnetic release device.
Close the door.
The point of the retaining catch will show where to insert it.
Reopen the door and press the retaining catch.

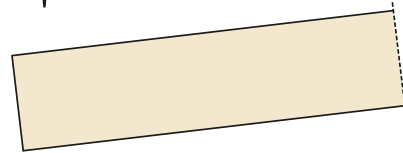
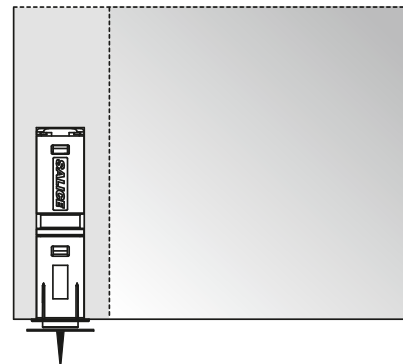

3 - Magnetic retaining catch to be inserted

The retaining catch DP39 is itself magnetic and together with the magnetism of the release device DPM considerably increase (30%) the holding strength of the door against the cabinet side, thus avoiding accidental openings.

For the installation it is necessary to drill a hole $\varnothing 15$ mm and 11 mm depth in the door.

Depth adjustment from -0.5 mm to +2.5 mm.

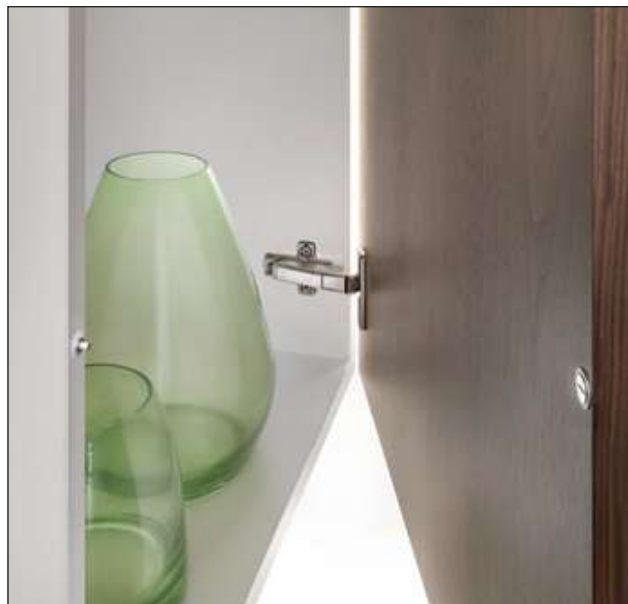
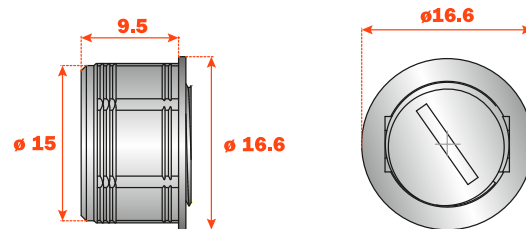
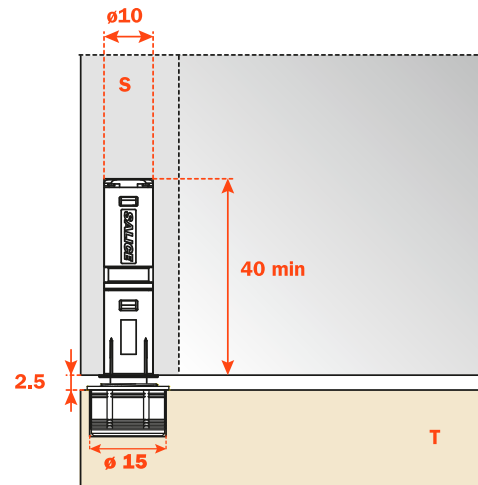

Adjustment -0.5 mm



Adjustment +2.5 mm



Push - Series 200 hinges



The Series 200 make up an integrated system of hinges developed to provide a solution to any situation involving concealed hinges.

Bright nickel plated steel cup and arm.
Dimensions of the $\varnothing 35$ mm cup.

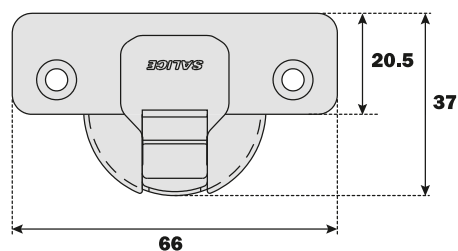

Constant "L" value of 0.7 mm (it does not change during side adjustment).

Approx. number of hinges required according to the door dimension and weight.

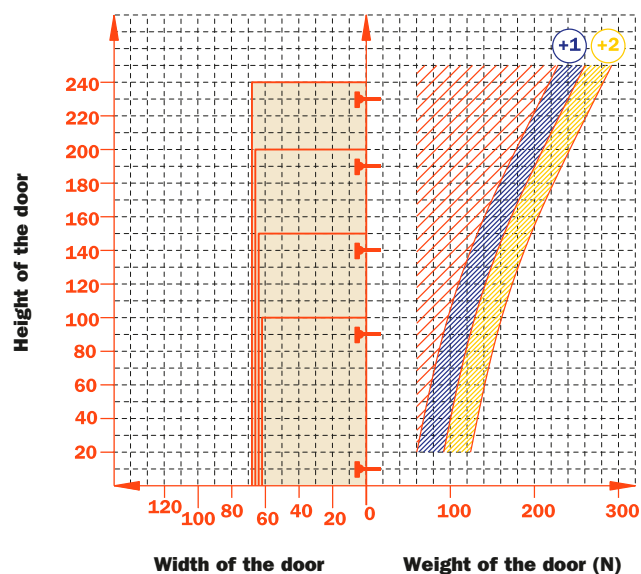

Adjustments

Compensating side adjustment from - 1.5 to + 4.5 mm.
Height adjustment ± 2 mm.
Depth adjustment with Series 200 mounting plates + 2.8 mm.
Depth adjustment with Domi snap-on mounting plates from - 0.5 mm to + 2.8 mm.
Anti-sliding safety stop.

Mounting plates

Symmetrical and asymmetrical bright nickel plated steel or die-cast Series 200 mounting plates.
Snap-on assembly on Domi mounting plates.
Positioning with pre-determined stop on traditional Series 200 mounting plates.

N.B. : Use POZIDRIVE No. 2 screwdrivers for all screws.



	94°	110°	155°
Wood screw	A	A	A
	P	P	P
	U	U	U

	94°	110°	155°
Rapido	6	6	6
Dowel	B	B	B
Logica	I	I	I
	J	J	J
	Q	Q	Q

**Use this table to identify the available drillings and fixings.
Fill the third position of the hinge code number with the letter or the number corresponding to your choice. I.e.: C2_PA99.**

↑
Fill this position with the chosen letter or number.

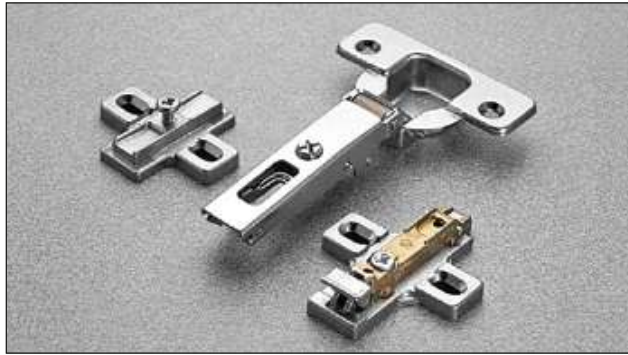

Technical information

Push hinges are equipped with a special spring that acts to open the door independently of the release device.

For thick doors up to 35 mm, with special profiles.
11 mm deep metal cup.
94° opening.

Possible drilling distance on the door (K): from 3 to 9 mm.
Compatible with all traditional Series 200 mounting plates
and with all Domi snap-on mounting plates.

Space needed to open the door

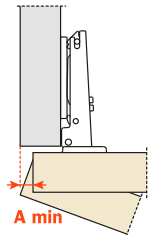

T=	19	20	21	22	23	24	25	26	27	28	29	30	31	32	33	34	35
K=3	A= 0.1	0.2	0.3	0.4	0.5	0.7	0.8	1.0	1.6	2.6	3.5	4.5	5.4	6.4	7.4	8.3	9.3
K=4	A= 0.1	0.2	0.3	0.4	0.5	0.7	0.8	1.0	1.2	1.9	2.8	3.8	4.7	5.7	6.6	7.6	8.6
K=5	A= 0.1	0.2	0.3	0.4	0.5	0.7	0.8	1.0	1.2	1.4	2.2	3.1	4.1	5.0	5.9	6.9	7.8
K=6	A= 0.1	0.2	0.3	0.4	0.5	0.6	0.8	1.0	1.2	1.4	1.7	2.6	3.5	4.4	5.3	6.2	7.2
K=7	A= 0.1	0.2	0.3	0.4	0.5	0.6	0.8	1.0	1.1	1.3	1.6	2.1	3.0	3.8	4.7	5.6	6.5
K=8	A= 0.1	0.2	0.3	0.4	0.5	0.6	0.8	0.9	1.1	1.3	1.6	1.8	2.5	3.3	4.2	5.1	6.0
K=9	A= 0.1	0.2	0.3	0.4	0.5	0.6	0.8	0.9	1.1	1.3	1.5	1.8	2.1	2.9	3.7	4.6	5.4

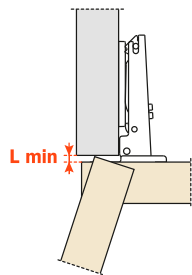

K=	3	4	5	6	7	8	9
L=	0.0	0.0	0.0	0.0	0.0	0.3	1.3

The above values are calculated on the assumption that the doors have square edges. They are reduced if the doors have radiussed edges.

Projection of the door

Projection of the door from the cabinet side at the max. opening. The figures are based on a straight arm hinge, H=0 mm thickness of mounting plate and K value = 3 mm.

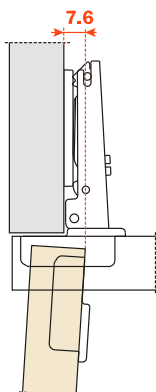

“C” value

With this formula you can obtain the max. thickness of the moulded door that can be opened without touching adjacent carcass sides, doors or walls, whilst bearing in mind the above L-K-T values.

$$C = 23 + K + A$$

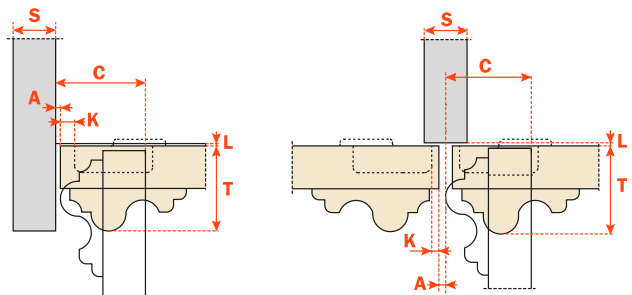

Packing

Boxes 300 pcs.
Pallets 7.200 pcs.

Use these formulas to determine the type of hinge arm, the drilling distance "K" and the height of the mounting plate "H" which is necessary to solve each application problem.

Use the tables "Drillings and fixings" at page 205 to complete the code number of the desired hinge.

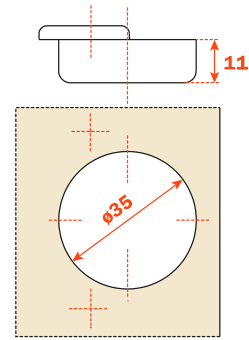

Arm 0

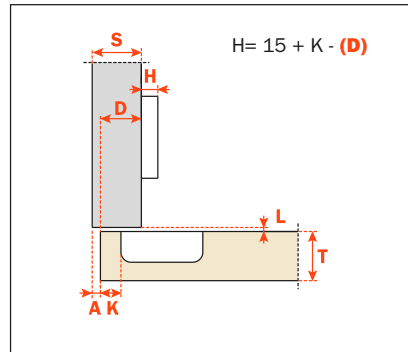

C2_VA99

Arm 5

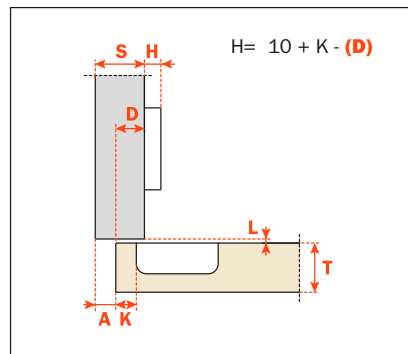

C2_VD99

Arm 9

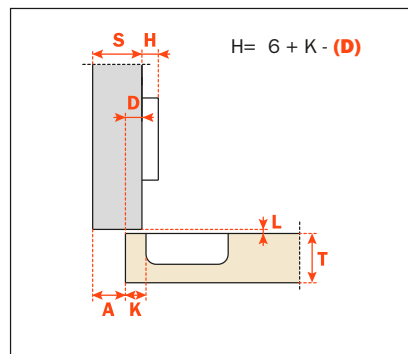

C2_VG99

Arm 17

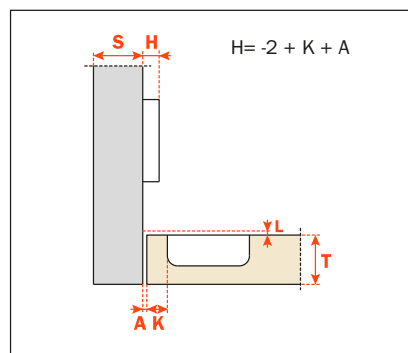

C2_VP99



Technical information

Push hinges are equipped with a special spring that acts to open the door independently of the release device.

When a greater opening angle is required.
 11 mm deep metal cup.
 110° opening.
 Possible drilling distance on the door (K): from 3 to 6 mm.
 Compatible with all traditional Series 200 mounting plates and with all Domi snap-on mounting plates.

Space needed to open the door

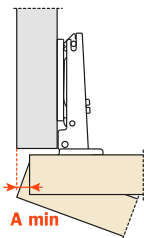

	T=	16	17	18	19	20	21	22	23	24	25	26
K=3	A=	0.5	0.7	0.9	1.2	1.5	1.8	2.4	3.7	5.1	6.5	7.8
K=4	A=	0.5	0.7	0.9	1.2	1.5	1.8	2.1	2.7	4.1	5.5	6.8
K=5	A=	0.5	0.7	0.9	1.2	1.5	1.8	2.1	2.6	3.1	4.1	5.4
K=6	A=	0.5	0.7	0.9	1.2	1.5	1.8	2.1	2.5	3.0	3.5	4.4

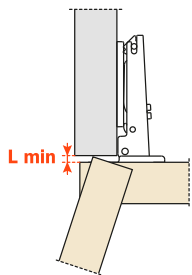

	T=	16	17	18	19	20	21	22	23	24	25	26
K=3	L=	0.0	0.0	0.0	0.0	0.2	0.5	0.8	1.1	1.4	1.7	1.9
K=4	L=	0.0	0.0	0.3	0.6	0.9	1.2	1.4	1.7	2.0	2.3	2.6
K=5	L=	1.1	1.3	1.6	1.8	2.1	2.3	2.6	2.9	3.1	3.4	3.6
K=6	L=	2.0	2.3	2.5	2.8	3.1	3.3	3.6	3.8	4.1	4.3	4.6

The above values are calculated on the assumption that the doors have square edges. They are reduced if the doors have radiussed edges.

Projection of the door

Projection of the door from the cabinet side at the max. opening. The figures are based on a straight arm hinge, H=0 mm thickness of mounting plate and K value = 3 mm.

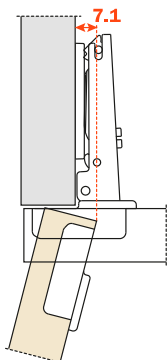

“C” value

With this formula you can obtain the max. thickness of the moulded door that can be opened without touching adjacent carcass sides, doors or walls, whilst bearing in mind the above L-K-T values.

$$C = 20 + K + A$$

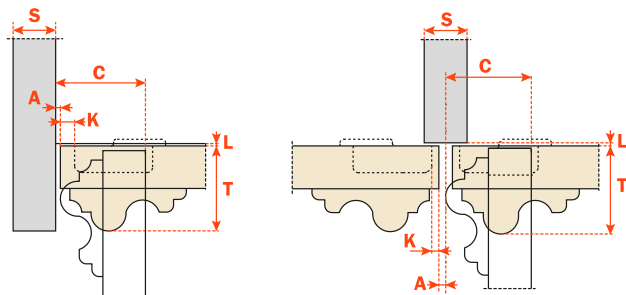

Packing

Boxes 300 pcs.
Pallets 7.200 pcs.

Use these formulas to determine the type of hinge arm, the drilling distance "K" and the height of the mounting plate "H" which is necessary to solve each application problem.

Use the tables "Drillings and fixings" at page 205 to complete the code number of the desired hinge.

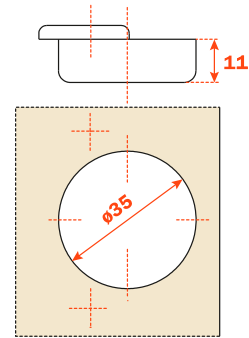

Arm 0

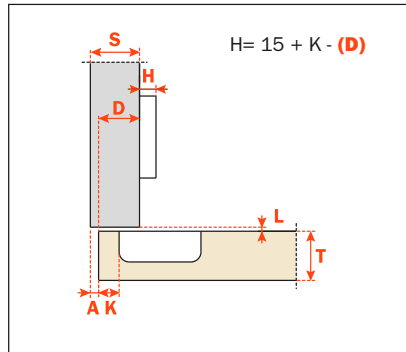

C2_PA99

Arm 5

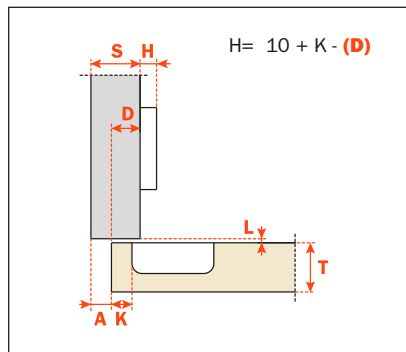

C2_PD99

Arm 9

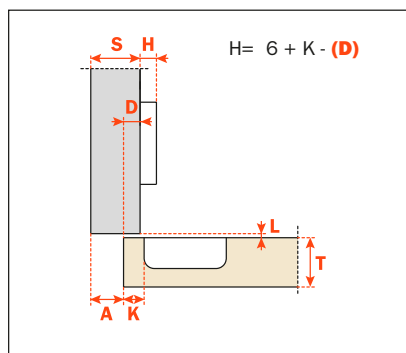

C2_PG99

Arm 17

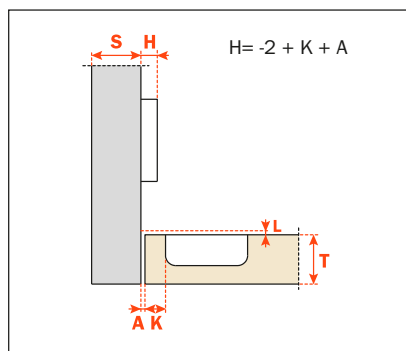

C2_PP99



Technical information

Push hinges are equipped with a special spring that acts to open the door independently of the release device.

For thick doors min. 10 mm.
 8 mm deep die-cast cup.
 With 0 mm door protrusion only with straight arm hinge.
 155° opening.
 Possible drilling distance on the door (K): from 3 to 8 mm.
 Compatible with all traditional Series 200 mounting plates and with all Domi snap-on mounting plates.

Space needed to open the door

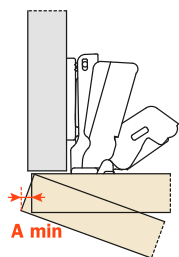

	T=	16	18	20	22
K=3	A=	0.0	0.0	0.3	1.2
K=4	A=	0.0	0.4	0.4	1.3
K=5	A=	0.0	0.1	0.5	1.6
K=6	A=	0.0	0.1	1.2	3.0
K=7	A=	0.0	0.1	0.7	2.5
K=8	A=	0.0	0.1	0.6	1.9

The above values are calculated on the assumption that the doors have square edges. They are reduced if the doors have radiussed edges.

“C” value

For spaces with removable components. The door opens at 90° with lateral door protrusion of 2 mm. The figures are based on a straight arm hinge and H=0 thickness of mounting plate.

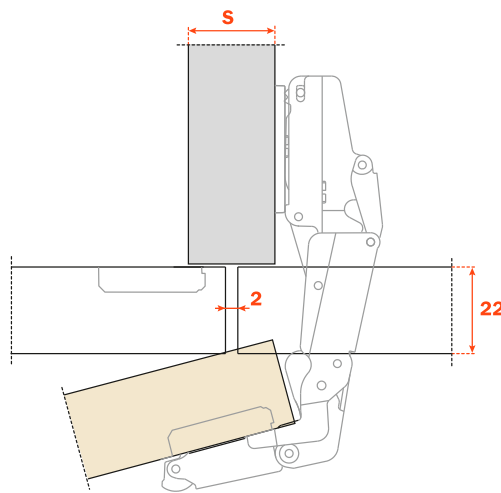
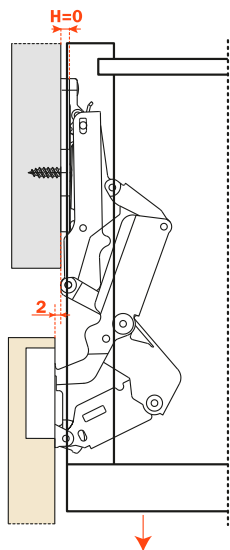

Packing

Boxes 100 pcs.
Pallets 2.400 pcs.

Use these formulas to determine the type of hinge arm, the drilling distance "K" and the height of the mounting plate "H" which is necessary to solve each application problem.

To limit the opening of the hinge, see page 354 chapter "Accessories".

Use the tables "Drillings and fixings" at page 205 to complete the code number of the desired hinge.

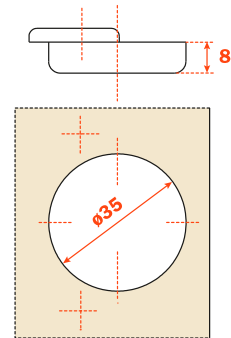

Arm 0

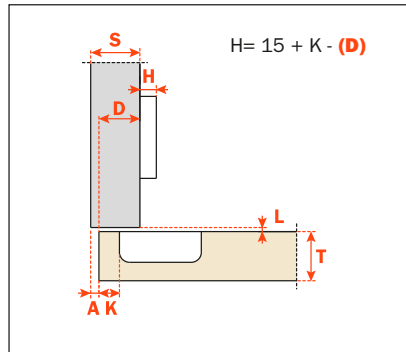

C2_UA99

Arm 5

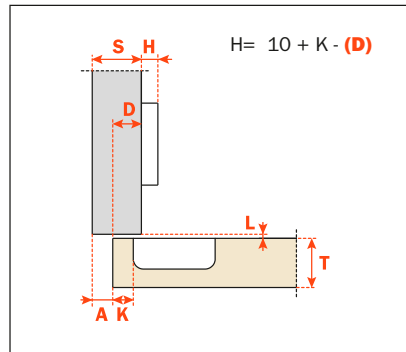

C2_UD99

Arm 9

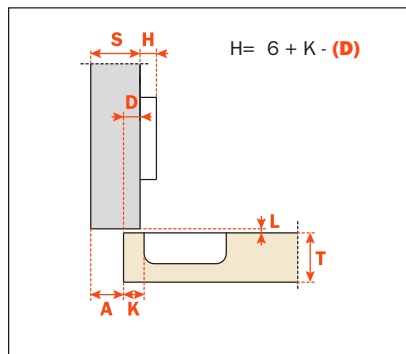

C2_UG99



Technical information

Push hinges are equipped with a special spring that acts to open the door independently of the release device.

For thick doors up to 35 mm.
 Hinge with greater opening angle and reduced operating profile.
 11 mm deep die-cast cup.
 155° opening.
 Possible drilling distance on the door (K): from 3 to 9 mm.
 Compatible with all traditional Series 200 mounting plates and with all Domi snap-on mounting plates.

Space needed to open the door

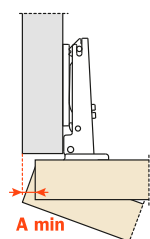

T=	26	27	28	29	30	31	32	33	34	35
K=3	A= 0.0	0.0	0.0	0.8	3.0	4.8	7.1	11.7	16.4	20.7
K=4	A= 0.0	0.0	0.0	0.8	2.5	4.0	6.2	10.6	15.0	19.7
K=5	A= 0.0	0.0	0.0	0.8	2.0	3.4	4.8	9.8	14.1	18.4
K=6	A= 0.0	0.0	0.0	0.8	1.5	2.8	4.2	8.7	13.2	17.8
K=7	A= 0.0	0.0	0.0	0.8	1.4	2.3	3.0	7.8	12.0	16.7
K=8	A= 0.0	0.0	0.0	0.2	0.9	1.9	2.7	7.0	11.2	15.7
K=9	A= 0.0	0.0	0.0	0.2	0.7	1.5	2.1	5.9	10.4	15.0

The above values are calculated on the assumption that the doors have square edges. They are reduced if the doors have radiussed edges.

“C” value

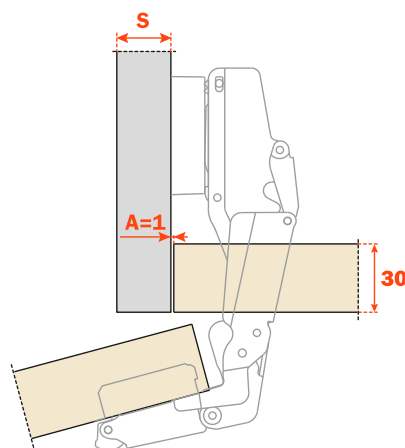
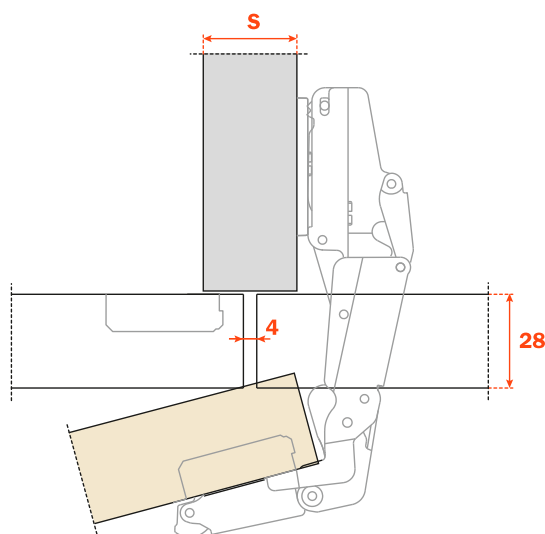

Packing

Boxes 100 pcs.
Pallets 2.400 pcs.

Use these formulas to determine the type of hinge arm, the drilling distance "K" and the height of the mounting plate "H" which is necessary to solve each application problem.

To limit the opening of the hinge, see page 354 chapter "Accessories".

Use the tables "Drillings and fixings" at page 205 to complete the code number of the desired hinge.

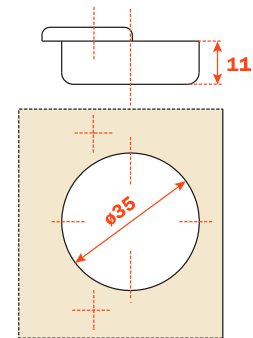

Arm 0

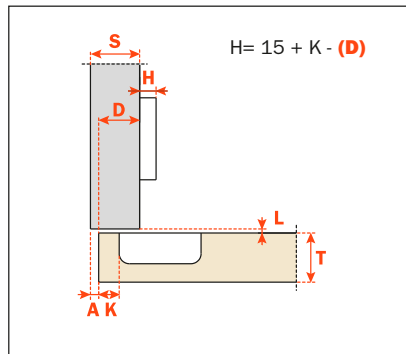

C2_TA99

Arm 5

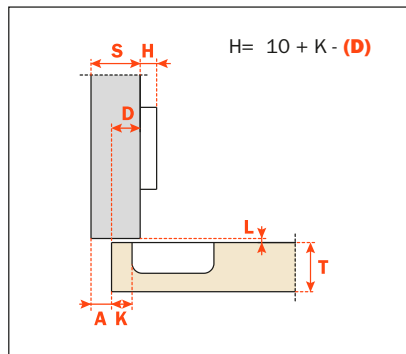

C2_TD99

Arm 9

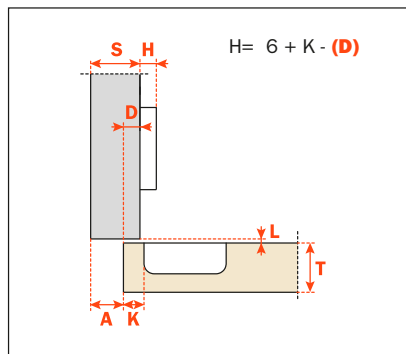

C2_TG99



Technical information

Push hinges are equipped with a special spring that acts to open the door independently of the release device.

Hinges for wooden doors with positive angled assembly.

11 mm deep metal cup.
 94° opening.
 Possible drilling distance on the door (K): from 3 to 9 mm.
 Compatible with all traditional Series 200 mounting plates and with all Domi snap-on mounting plates.

Packing

Boxes 150 pcs.
 Pallets 3.600 pcs.

The solution of assembly problems where doors are mounted at a positive angle requires the verification of drilling distances by a practical trial. Please do not hesitate to consult our technical support department for assistance.

Use the tables "Drillings and fixings" at page 205 to complete the code number of the desired hinge.

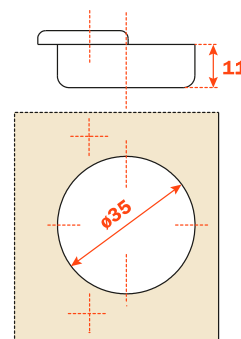

Arm 15°

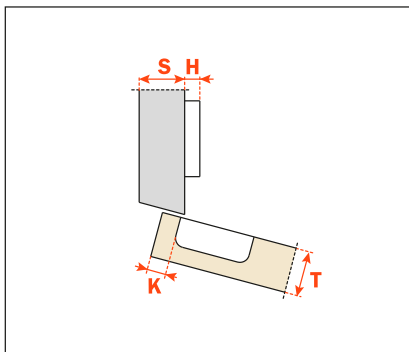

C2_VZ99

Arm 24°

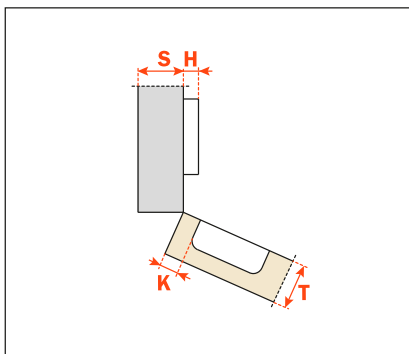

C2_VU99

Arm 30°

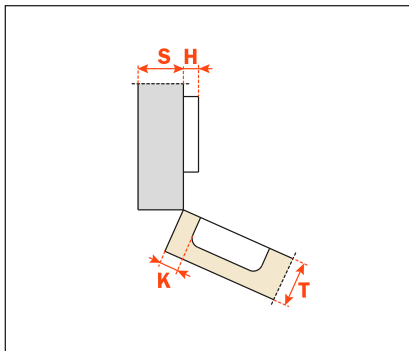

C2_VE99

Arm 30°

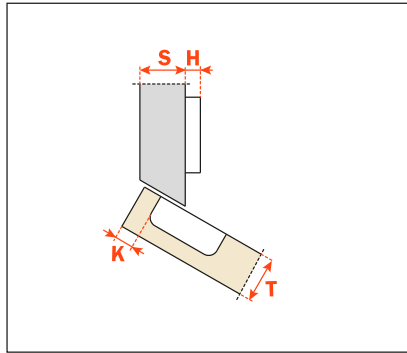

C2_VT99

Arm 37°

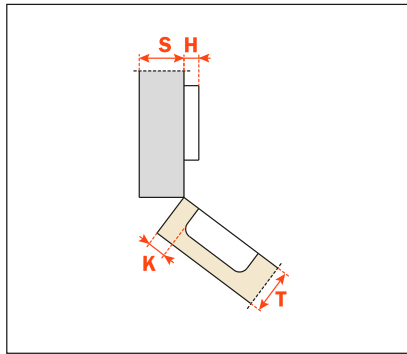

C2_VK99

Arm 45°

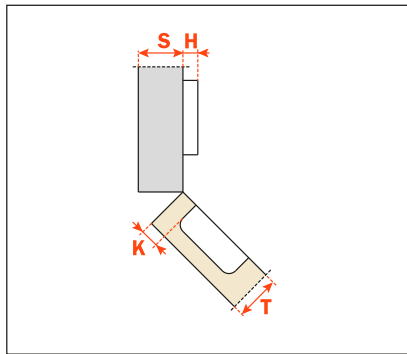

C2_VM99

Arm 45°

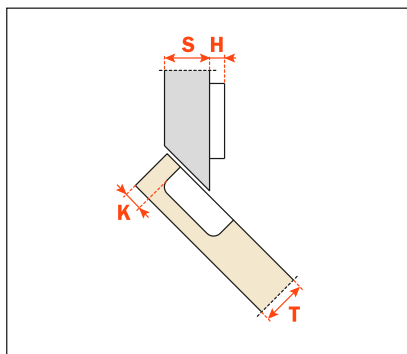

C2_VV99

Arm 45°

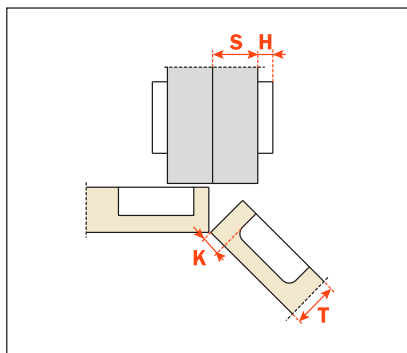

C2_VM99AC



Technical information

Push hinges are equipped with a special spring that acts to open the door independently of the release device.

Crampon hinges.

For cabinet sides with 37x32 mm standard drilling.

11 mm deep metal cup.

94° opening.

Possible drilling distance on the door (K): from 3 to 9 mm.

Compatible with all traditional Series 200 mounting plates and with all Domi snap-on mounting plates.

Packing

Boxes 150 pcs.

Pallets 3.600 pcs.

E min:

61 mm for Series 200 mounting plates.

70 mm for Domi snap-on mounting plates.

74 mm for Domi snap-on mounting plates with back cam.

Use the tables "Drillings and fixings" at page 205 to complete the code number of the desired hinge.

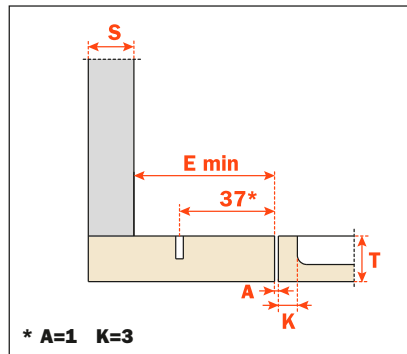
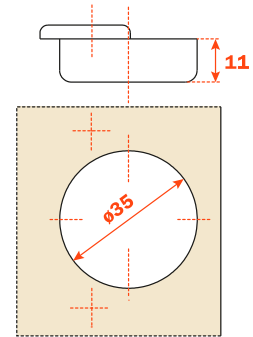

* A=1 K=3

C2_VN99AC

Heights of mounting plates for every assembly.

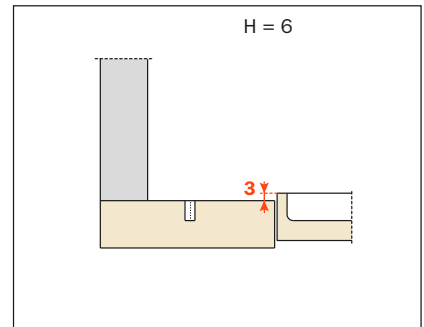
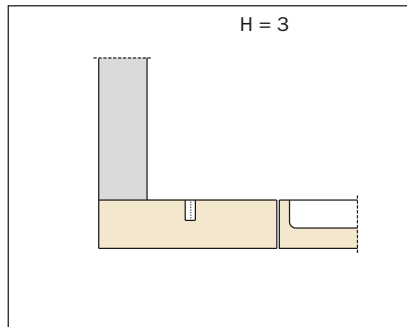
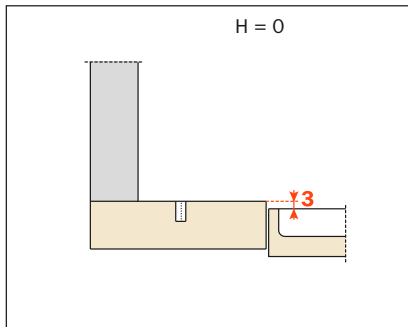



Technical information

Push hinges are equipped with a special spring that acts to open the door independently of the release device.

Crampon hinges.

For smaller spaces with 15x32 mm drilling.

11 mm deep metal cup.

94° opening.

Possible drilling distance on the door (K): from 3 to 9 mm.

Compatible with all traditional Series 200 mounting plates, 28x32 mm drilling.

NOT COMPATIBLE with Domi snap-on mounting plates.

Packing

Boxes 150 pcs.

Pallets 3.600 pcs.

Use the tables "Drillings and fixings" at page 205 to complete the code number of the desired hinge.

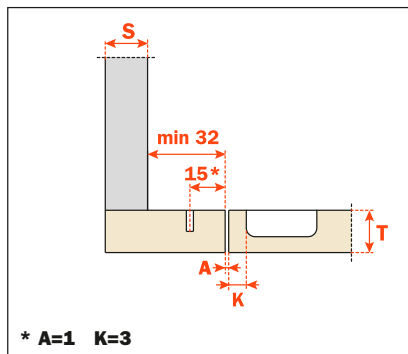
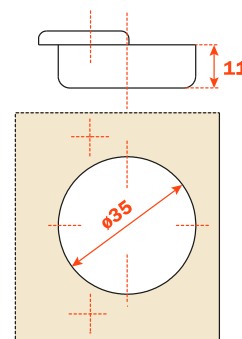

C2_VN99

Heights of mounting plates for every assembly.

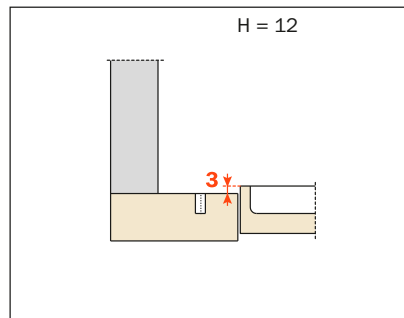
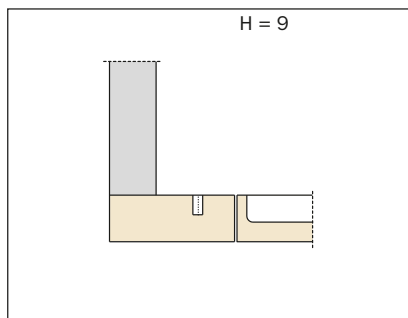
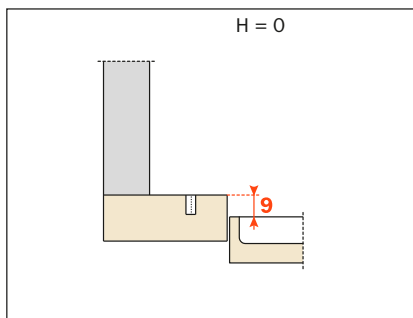

Push - Hinges for metal profiles



Push - Practical hinges - 105° opening



Technical information

Push hinges are equipped with a special spring that acts to open the door independently of the release device.

Hinges for the Practical system have been developed for use with special metal profiles. The particular fixing system does not require any profile working. The hinge can be therefore assembled at any point of the frame.

105° opening.

Compatible with all traditional Series 200 mounting plates and with all Domi snap-on mounting plates.

Packing

Boxes 150 pcs.

Pallets 3.600 pcs.

Arm 0

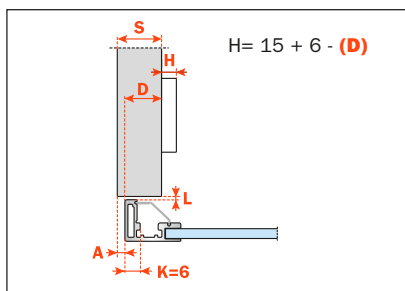

C20PA99

Arm 5

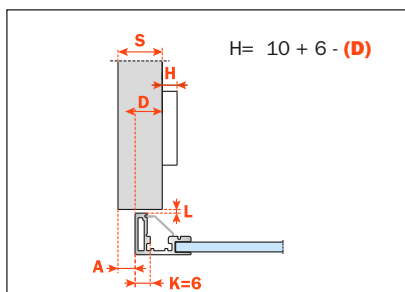

C20PD99

Arm 9

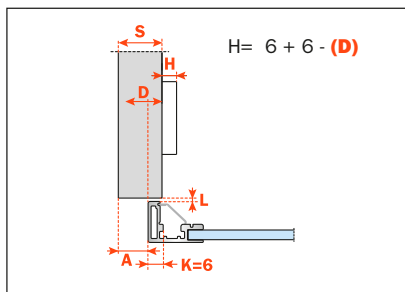

C20PG99

Arm 17

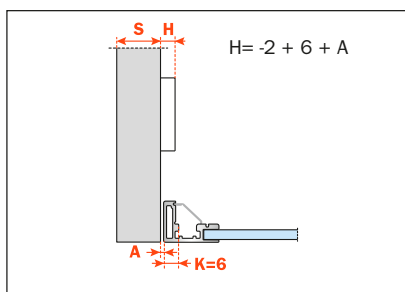

C20PP99



Technical information

Push hinges are equipped with a special spring that acts to open the door independently of the release device.

Hinges for doors with positive angled assembly.
 Hinges for the Practical system have been developed for use with special metal profiles. The particular fixing system does not require any profile working. The hinge can be therefore assembled at any point of the frame.
 105° opening.
 Compatible with all traditional Series 200 mounting plates and with all Domi snap-on mounting plates.

Packing

Boxes 150 pcs.
 Pallets 3.600 pcs.

Arm 30°

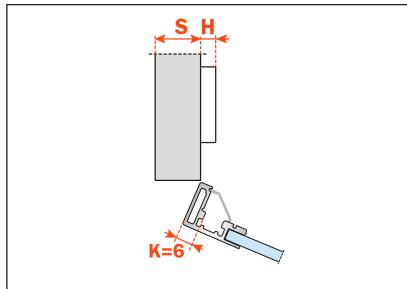

C20PE99

Arm 45°

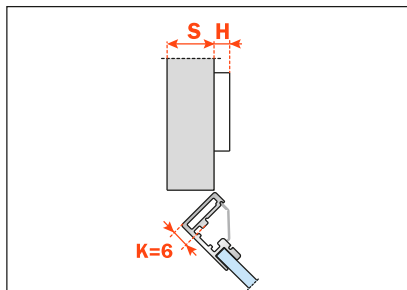

C20PM99

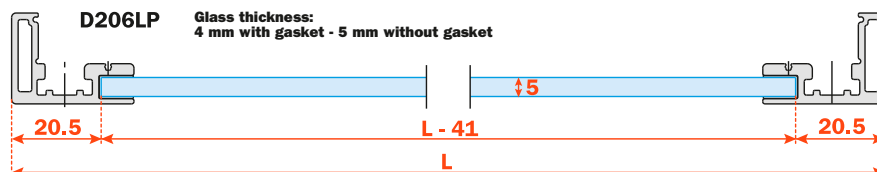
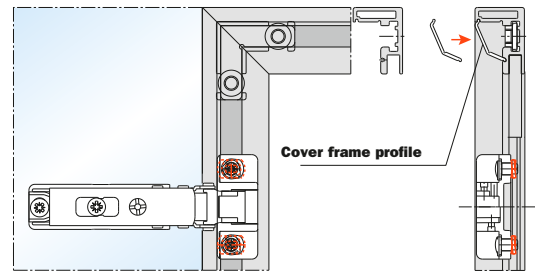
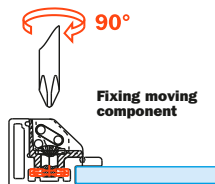
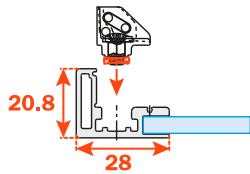



Packing

Boxes 150 pcs.
Pallets 3.600 pcs.

Technical information

Push hinges are equipped with a special spring that acts to open the door independently of the release device.

Crampon hinges.

For cabinet sides with 37x32 mm standard drilling.

Hinges for the Practical system have been developed for use with special metal profiles. The particular fixing system does not require any profile working. The hinge can be therefore assembled at any point of the frame.

105° opening.

Compatible with all traditional Series 200 mounting plates and with all Domi snap-on mounting plates.

E min:

61 mm for Series 200 mounting plates.

70 mm for Domi snap-on mounting plates.

74 mm for Domi snap-on mounting plates with back cam.

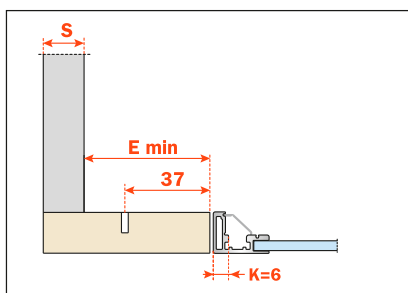

C20PN99AC



Packing

Boxes 150 pcs.
Pallets 3.600 pcs.

Technical information

Push hinges are equipped with a special spring that acts to open the door independently of the release device.

Crampon hinges.

For smaller spaces with 15x32 mm drilling.

Hinges for the Practical system have been developed for use with special metal profiles. The particular fixing system does not require any profile working. The hinge can be therefore assembled at any point of the frame.

105° opening.

Compatible with all traditional Series 200 mounting plates, 28 x 32 mm drilling.

NOT COMPATIBLE with Domi snap-on mounting plates.

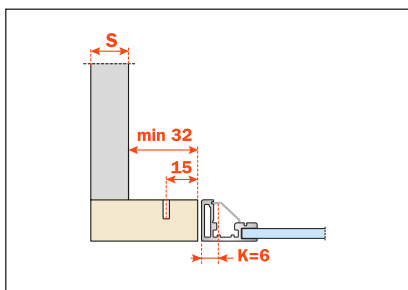

C20PN99



Technical information

Push hinges are equipped with a special spring that acts to open the door independently of the release device.

Hinges specially developed for use with metal profiles. 105° opening.
 We recommend the use of self-threading screws B 3.5 x 9.5 DIN 7982 to fix C2ZP hinges.
 Compatible with all traditional Series 200 mounting plates and with all Domi snap-on mounting plates.

Packing

Boxes 150 pcs.
 Pallets 3.600 pcs.

Arm 0

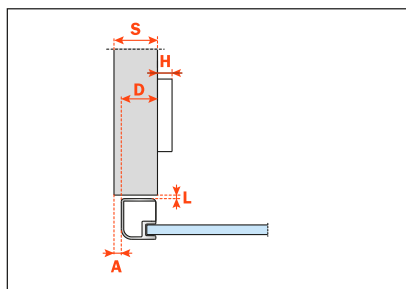

C2ZPA99

Arm 5

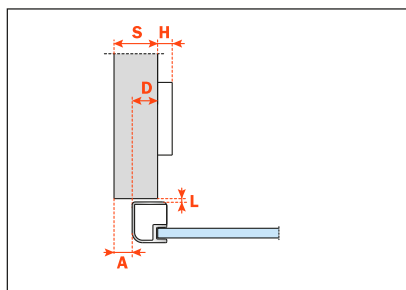

C2ZPD99

Arm 9

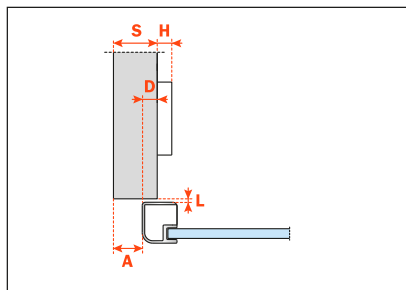

C2ZPG99

Arm 17

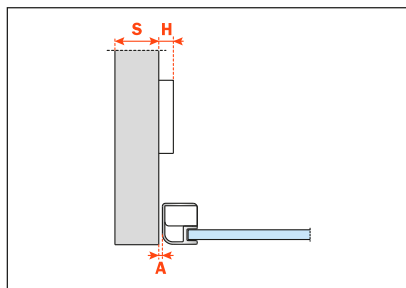

C2ZPP99

Push - Hinges for metal profiles - Complementary hinges



Technical information

Push hinges are equipped with a special spring that acts to open the door independently of the release device.

Hinges for doors with positive angled assembly.

Hinges specially developed for use with metal profiles. 105° opening.

We recommend the use of self-threading screws B 3.5 x 9.5 DIN 7982 to fix C2ZP hinges.

Compatible with all traditional Series 200 mounting plates and with all Domi snap-on mounting plates.

Packing

Boxes 150 pcs.

Pallets 3.600 pcs.

Arm 30°

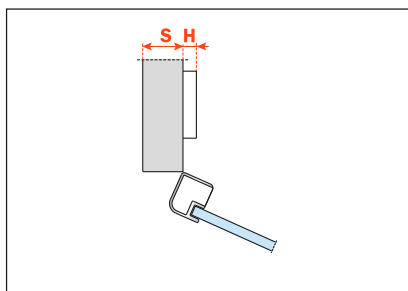

C2ZPE99

Arm 45°

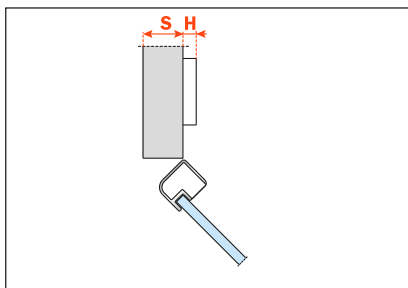

C2ZPM99

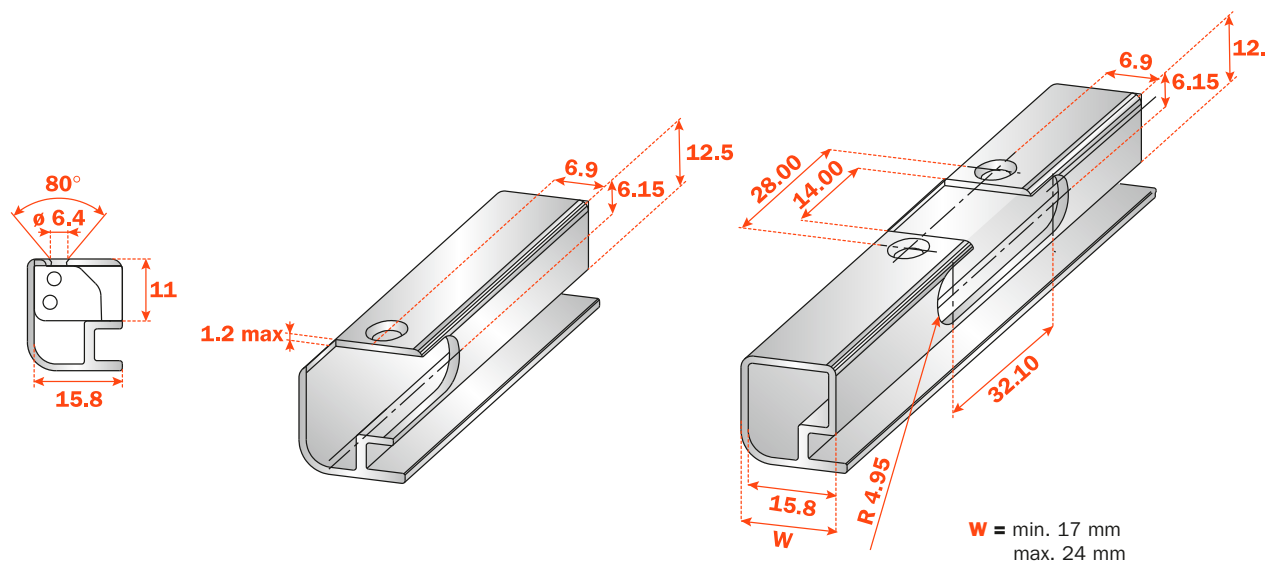

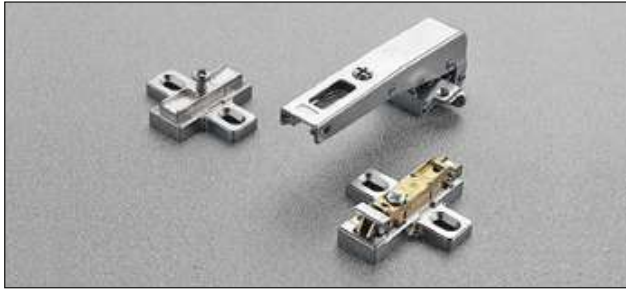

Packing

Boxes 150 pcs.
Pallets 3.600 pcs.

Technical information

Push hinges are equipped with a special spring that acts to open the door independently of the release device.

Crampon hinges.

For cabinet sides with 37x32 mm standard drilling.

Hinges specially developed for use with metal profiles.
105° opening.
We recommend the use of self-threading screws B 3.5 x 9.5 DIN 7982 to fix C2ZP hinges.
Compatible with all traditional Series 200 mounting plates and with all Domi snap-on mounting plates.

E min:

61 mm for Series 200 mounting plates.
70 mm for Domi snap-on mounting plates.
74 mm for Domi snap-on mounting plates with back cam.

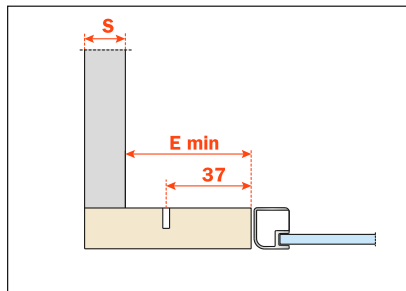

C2ZPN99AC



Packing

Boxes 150 pcs.
Pallets 3.600 pcs.

Technical information

Push hinges are equipped with a special spring that acts to open the door independently of the release device.

Crampon hinges.

For smaller spaces with 15x32 mm drilling.

Hinges specially developed for use with metal profiles.
105° opening.
We recommend the use of self-threading screws B 3.5 x 9.5 DIN 7982 to fix C2ZP hinges.
Compatible with all traditional Series 200 mounting plates, drilling 28x32 mm.

NOT COMPATIBLE with Domi snap-on mounting plates.

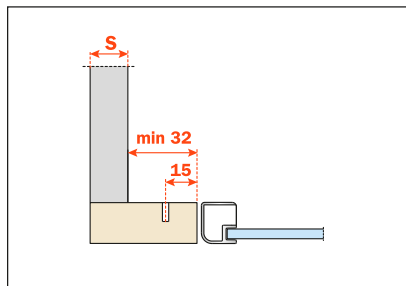

C2ZPN99

Push - Series B hinges



Push - Series B hinges for glass doors

Technical features

No drilling of the glass is required.
Bright nickel plated die-cast cup and arm.

Disclaimer

Salice Series B (CBG) hinges have been developed for use on glass doors and mirrors. Salice will accept no responsibility for any problems associated with the type of adhesive or method of application when used in conjunction with Series B hinges, nor for any consequences of the incorrect mounting of the door. It is recommended that the selected adhesive is subjected to prior testing. The adhesive may be considered appropriate if the plate, when fixed to the glass, can sustain a minimum torsion load of 160 Nm.

Constant "L" value of 0.7 mm (it does not change during side adjustment).

Approx. number of hinges required according to the door dimension and weight.

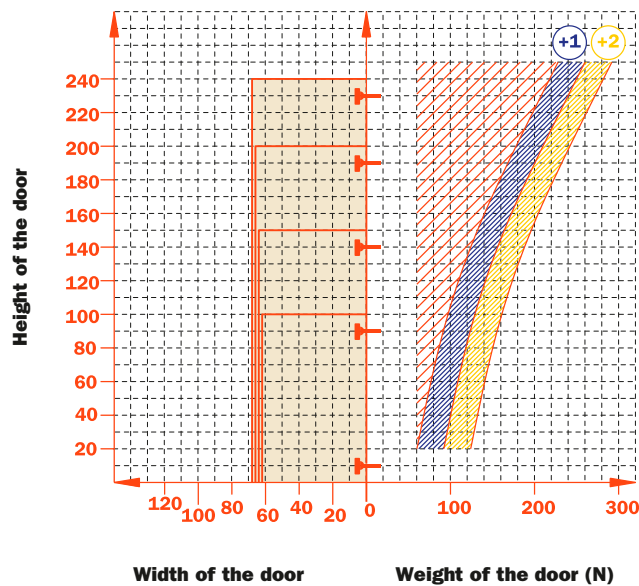

Adjustments

Compensated side adjustment from -1.5 mm to +4.5 mm.
Height adjustment ± 2 mm.
Depth adjustment with Series 200 mounting plates +2.8 mm.
Depth adjustment with Domi snap-on mounting plates from -0.5 mm to +2.8 mm.
Anti-sliding safety stop.

Mounting plates

Symmetrical and asymmetrical bright nickel plated steel or die-cast Series 200 mounting plates.
Snap-on assembly on Domi mounting plates.
Positioning with pre-determined stop on traditional Series 200 mounting plates.

N.B. : Use POZIDRIVE No. 2 screwdrivers for all screws.

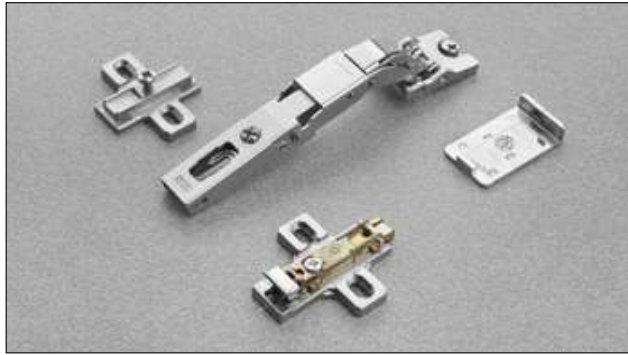

Technical information

Push hinges are equipped with a special spring that acts to open the door independently of the release device.

Hinge for glass doors. No drilling of the glass is required.
Possible fixing inset distance on the door (K): from 0 to 22 mm.
110° opening.
Compatible with all traditional Series 200 mounting plates and with all Domi snap-on mounting plates.

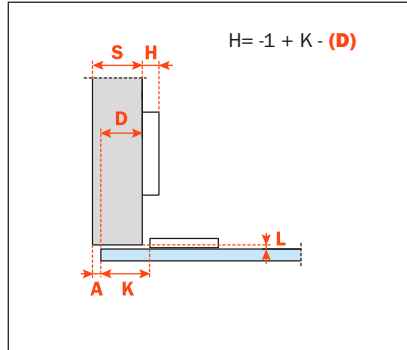
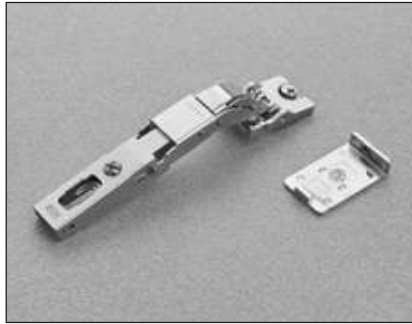

CBGQA99

Packing
Boxes 150 pcs.
Pallets 3.600 pcs.

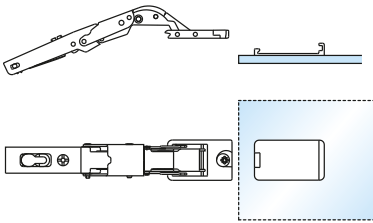

1) The hinge plate must be attached to the glass door or mirror by a special adhesive. We recommend that this operation is carried out by a specialist company. For further information on adhesives and their application, please contact the adhesive manufacturer or your glass supplier.

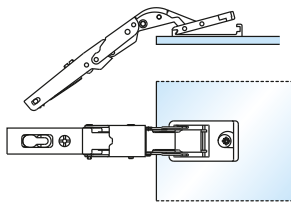

2) Fix the hinge when the plate is bonded to the glass.

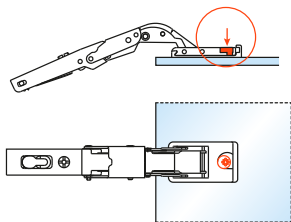

3) Locate the hinge cup onto the plate and rotate the cam.

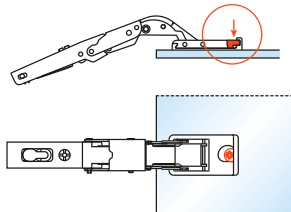

4) The hinge is now fixed to the door.

“C” Value

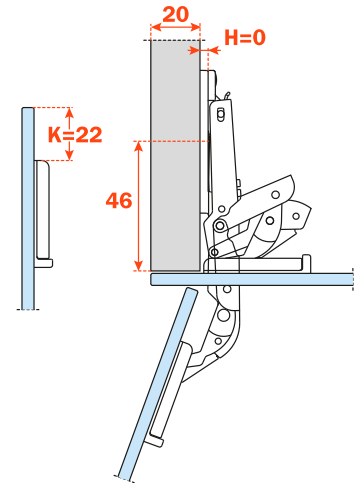

$K = 0 - 22$

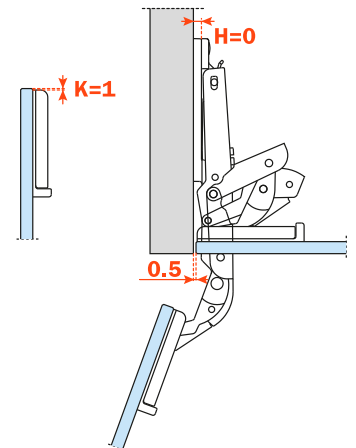

Push - Series B hinges for wooden doors

Technical features

Series B hinges can provide a solution to a number of special applications, which include half-inset doors and doors with moulded profiles. Dimensions of the 35 mm cup. Bright nickel plated die-cast cup and arm.

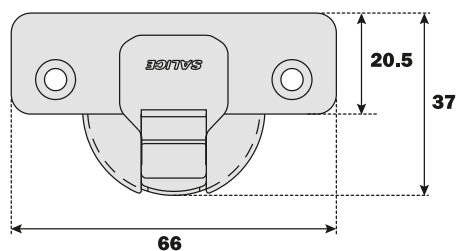

Constant "L" value of 0.7 mm (it does not change during side adjustment).

Approx. number of hinges required according to the door dimension and weight.

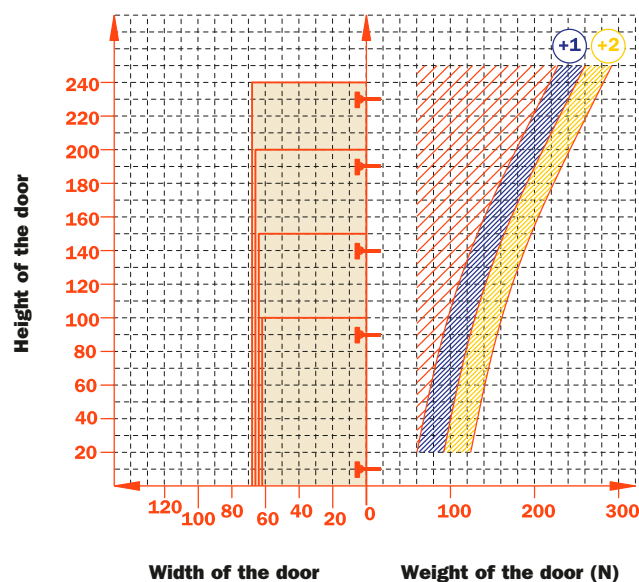

Adjustments

Compensated side adjustment from -1.5 mm to +4.5 mm.
Height adjustment ± 2 mm.
Depth adjustment with Series 200 mounting plates +2.8 mm.
Depth adjustment with Domi snap-on mounting plates from -0.5 mm to +2.8 mm.
Anti-sliding safety stop.

Mounting plates

Symmetrical and asymmetrical bright nickel plated steel or die-cast Series 200 mounting plates.
Snap-on assembly on Domi mounting plates.
Positioning with pre-determined stop on traditional Series 200 mounting plates.

N.B. : Use POZIDRIVE No. 2 screwdrivers for all screws.

	<p style="text-align: center;">110°</p>	<p style="text-align: center;">110°</p>	<p style="text-align: center;">110°</p>
<p>Wood screw</p>	A	P	U
	<p style="text-align: center;">110°</p>	<p style="text-align: center;">110°</p>	<p style="text-align: center;">110°</p>
<p>Dowel</p>	B	R	W

**Use this table to identify the available drillings and fixings.
 Fill the third position of the hinge code number with the letter or the number
 corresponding to your choice. I.e.: CB_QA99.**

↑
 Fill this position with the chosen letter or number.



Technical information

Push hinges are equipped with a special spring that acts to open the door independently of the release device and can provide a solution to a number of special applications, which include half-inset doors and doors with moulded profiles.

9 mm deep metal cup.
 110° opening.
 Possible drilling distance on the door (K): from 3 to 18 mm.
 Compatible with all traditional Series 200 mounting plates and with all Domi snap-on mounting plates.

Space needed to open the door

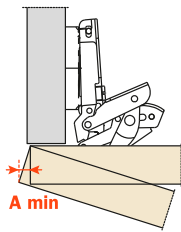

	T=	16	18	20	22	24	26
K=3	A=	0.0	0.0	0.0	0.0	0.3	1.4
K=4	A=	0.0	0.0	0.0	0.0	0.4	1.5
K=5	A=	0.0	0.0	0.0	0.0	0.5	1.9
K=6	A=	0.0	0.0	0.0	0.0	0.7	2.6
K=7	A=	0.0	0.0	0.0	0.0	11.3	12.8
K=8	A=	0.0	0.0	0.0	0.0	10.3	12.9
K=9	A=	0.0	0.0	0.0	0.0	9.3	11.9
K=10	A=	0.0	0.0	0.0	6.0	8.3	10.9
K=11	A=	0.0	0.0	0.0	5.1	7.3	9.9
K=12	A=	0.0	0.0	0.0	4.1	6.3	8.9
K=13	A=	0.0	0.0	1.4	3.3	5.3	7.9
K=14	A=	0.0	0.0	0.7	2.6	4.5	6.9
K=15	A=	0.0	0.0	0.2	2.0	3.8	5.9
K=16	A=	0.0	0.0	0.0	1.4	3.2	5.0
K=17	A=	0.0	0.0	0.0	1.0	2.7	4.4
K=18	A=	0.0	0.0	0.0	0.7	2.2	3.9

The above values are calculated on the assumption that the doors have square edges. They are reduced if the doors have radiussed edges.

Projection of the door

Projection of the door from the cabinet side at the max. opening. The figures are based on a straight arm hinge, H=0 mm thickness of mounting plate and K value = 3 mm.

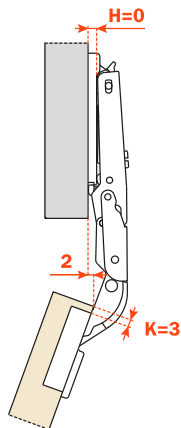

“C” value

With this formula you can obtain the max. thickness of the moulded door that can be opened without touching adjacent carcass sides, doors or walls, whilst bearing in mind the above L-K-T values.

$$C = 5.5 + K + A$$

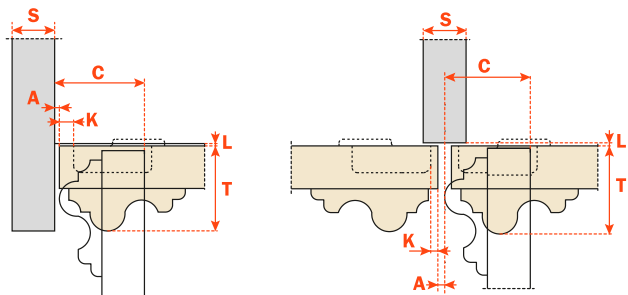

Packing

Boxes 150 pcs.
Pallets 3.600 pcs.

Use these formulas to determine the type of hinge arm, the drilling distance "K" and the height of the mounting plate "H" which is necessary to solve each application problem.

To limit the opening of the hinge, see page 354 chapter "Accessories".

Use the tables "Drillings and fixings" at page 231 to complete the code number of the desired hinge.

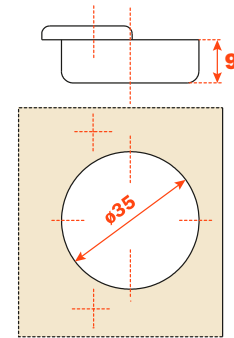

Arm 0

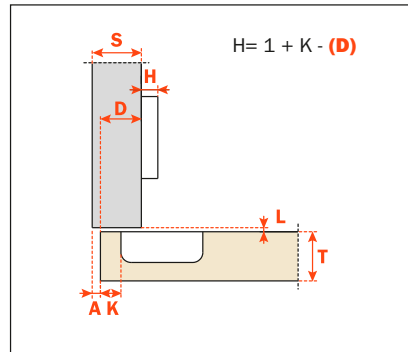
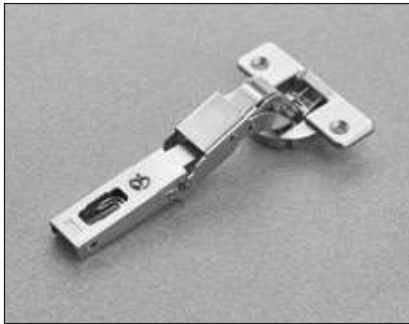

CB_QA99

Domi snap-on mounting plates



Domi snap-on mounting plates

Domi snap-on mounting plates

- Domi snap-on mounting plates. For hinges Series 100, 200, 400, F, B, M and Silentia.
- 21+32 mm drilling.
- Depth and height adjustment by cam.

Packing

Boxes 300 pcs.
Pallets 7.200 pcs.

BAP3R



Die-cast mounting plates.
Fixing: wood screw.

B 3.5 DIN 7983.

H= 0 1 2 3 4 5 6 9 12

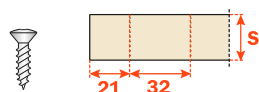

BAPGR



Die-cast mounting plates.
Fixing: Euroscrew.
Drilling $\varnothing 5 \times 11$.

H= 0 1 2 3 4 5 6 9 12

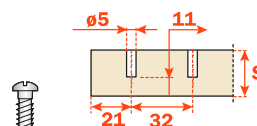

BAPMR



Die-cast mounting plates.
Fixing: expanding dowel.
Drilling $\varnothing 10 \times 11.5$ mm.

H= 0 1 2 3 4 5 6 9 12

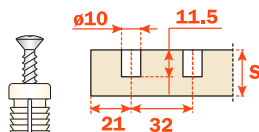

BAP7R



Die-cast mounting plates.
Fixing: knock-in dowel.
Drilling $\varnothing 10 \times 11.5$ mm.

H= 0 1 2 3 4 5 6 9 12

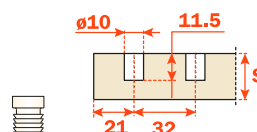

- Cruciform Domi snap-on mounting plates. For hinges Series 100, 200, 400, F, B, M and Silentia.
- 37x32 mm drilling.
- Depth and height adjustment by cam.

Packing

Boxes 300 pcs.
Pallets 7.200 pcs.

BAR3R



Die-cast mounting plates.
Fixing: wood screw.

B 3.5 DIN 7983.

H= 0 1 2 3 4 5 6 9 12

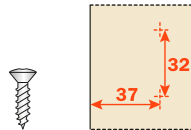

BAR4R



Die-cast mounting plates.
Fixing: expanding dowel.
Drilling $\varnothing 5 \times 11$ mm.

H= 0 1 2 3 4 5 6 9 12

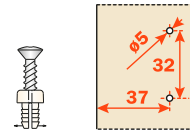

BARMR



Die-cast mounting plates.
Fixing: expanding dowel.
Drilling $\varnothing 10 \times 11.5$ mm.

H= 0 1 2 3 4 5 6 9 12

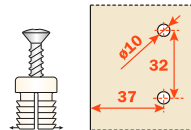

BARGR



Die-cast mounting plates.
Fixing: Euro screw.
Drilling $\varnothing 5 \times 11$ mm.

H= 0 1 2 3 4 5 6 9 12

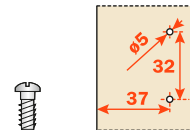

BAR7R



Die-cast mounting plates.
Fixing: knock-in dowel.
Drilling $\varnothing 10 \times 11.5$ mm.

H= 0 1 2 3 4 5 6 9 12

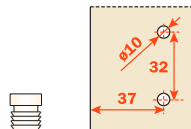

BARGR



Die-cast mounting plates.
Fixing: Euro screw.
Drilling $\varnothing 5 \times 11$ mm.

H= 18 19 20 21 22 23 24 27 30

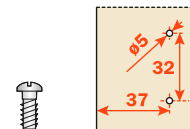

BAR3L/F



Steel mounting plates.
Fixing: wood screw.

B 4.2 DIN 7983

H= 0 2 3 4 6

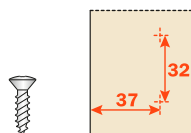

BARGL/F



Steel mounting plates.
Fixing: Euro screw.
Drilling $\varnothing 5 \times 11$ mm.

H= 0 2 3 4 6

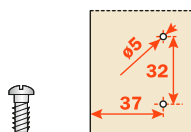

BAR7L/F



Steel mounting plates.
Fixing: knock-in dowel.
Drilling $\varnothing 10 \times 11.5$ mm.

H= 0 2 3 4 6

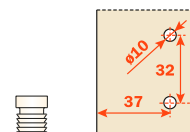

Domi snap-on mounting plates

- Cruciform Domi snap-on mounting plates. For hinges Series 100, 200, 400, F, B, M and Silentia.
- 37x32 mm drilling.
- Depth adjustment by cam.

Packing

Boxes 300 pcs.
Pallets 7.200 pcs.

BAV3M/F



Steel mounting plates.
Fixing: wood screw.

B 3.5 DIN 7983.

H= 0 2 3

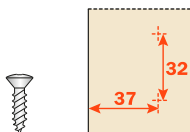

BAV3E/F



Die-cast mounting plates.
Fixing: wood screw.

B 3.5 DIN 7983.

H= 4 6 9 12 18

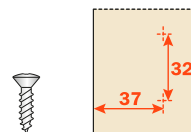

BAVGM/F



Steel mounting plates.
Fixing: Euroscrow.
Drilling $\varnothing 5 \times 11$ mm.

H= 0 2 3

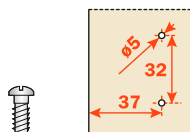

BAVGE/F



Die-cast mounting plates.
Fixing: Euroscrow.
Drilling $\varnothing 5 \times 11$ mm.

H= 4 6 9 12 18

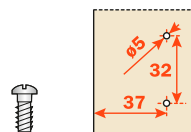

BAV4M/F



Steel mounting plates.
Fixing: expanding dowel.
Drilling $\varnothing 5 \times 7.5$ mm.

H= 0 2 3

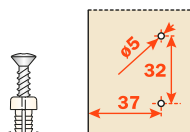

BAV4E/F



Die-cast mounting plates.
Fixing: expanding dowel.
Drilling $\varnothing 5 \times 7.5$ mm.

H= 4 6 9 12 18

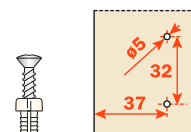

BAV7M/F



Steel mounting plates.
Fixing: knock-in dowel.
Drilling $\varnothing 10 \times 10$ mm.

H= 0 2 3

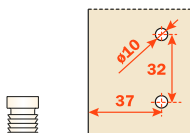

BAV7E/F



Die-cast mounting plates.
Fixing: knock-in dowel.
Drilling $\varnothing 10 \times 10$ mm.

H= 4 6 9 12 18

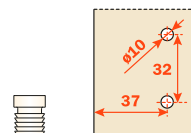

Series 200 mounting plates with traditional assembly



Series 200 mounting plates
with traditional assembly

Series 200 mounting plates with traditional assembly

- Asymmetrical cruciform mounting plates. For hinges Series 100, 200, 400, 600, 900, F, B, M and Silentia.
- **For hinges series 800 use steel mounting plates only.**
- 28x32 mm drilling.
- Height adjustment ± 2 mm.

Packing

Boxes 600 pcs.
Pallets 14.400 pcs.

B2S3H



Steel mounting plates.
Fixing: wood screw.

B 3.5 DIN 7983.

H= 0 1 2 3

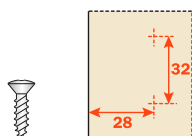

B2S3B



Die-cast mounting plates.
Fixing: wood screw.

B 3.5 DIN 7983.

H= 6 9 12

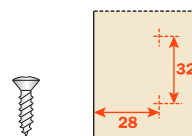

B2SGH



Steel mounting plates.
Fixing: Euro screw.
Drilling $\varnothing 5 \times 11$ mm.

H= 0 1 2 3

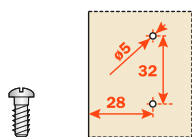

B2SGB



Die-cast mounting plates.
Fixing: Euro screw.
Drilling $\varnothing 5 \times 11$ mm.

H= 6 9 12

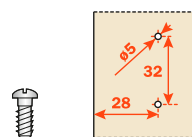

B2S4H



Steel mounting plates.
Fixing: expanding dowel.
Drilling $\varnothing 5 \times 7.5$ mm.

H= 0 1 2 3

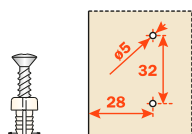

B2S7H



Steel mounting plates.
Fixing: knock-in dowel.
Drilling $\varnothing 10 \times 10$ mm.

H= 0 1 2 3

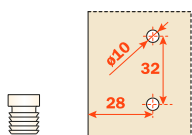

- Symmetrical cruciform mounting plates. For hinges Series 100, 200, 400, 600, 800, 900, F, B, M and Silentia.

- **For hinges series 800 use steel mounting plates only.**

- 37x32 mm drilling.

- Height adjustment ± 2 mm.

ATTENTION! Mounting plates with negative value can be used on D-G-P arms only.

Packing

Boxes 600 pcs.

Pallets 14.400 pcs.

B2V3H



Steel mounting plates.
Fixing: wood screw.

B 3.5 DIN 7983.

H= -2 0 2 3 4 6 9

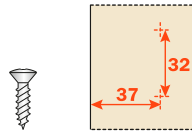

B2V3B



Die-cast mounting plates.
Fixing: wood screw.

B 3.5 DIN 7983.

H= 12 18

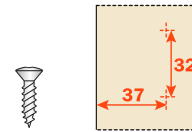

B2VGH



Steel mounting plates.
Fixing: Euro screw.
Drilling $\varnothing 5 \times 11$ mm.

H= -2 0 2 3 4 6 9

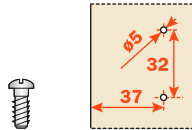

B2VGB



Die-cast mounting plates.
Fixing: Euro screw.
Drilling $\varnothing 5 \times 11$ mm.

H= 12 18

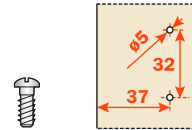

B2V4H



Steel mounting plates.
Fixing: expanding dowel.
Drilling $\varnothing 5 \times 7.5$ mm.

H= 0 2 3 4 6 9

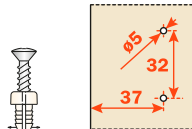

B2V4B



Die-cast mounting plates.
Fixing: expanding dowel.
Drilling $\varnothing 5 \times 7.5$ mm.

H= 12 18

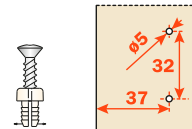

B2V7H



Steel mounting plates.
Fixing: knock-in dowel.
Drilling $\varnothing 10 \times 10$ mm.

H= 0 2 3 4 6 9

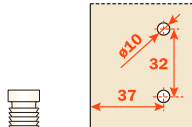

B2V7B



Die-cast mounting plates.
Fixing: knock-in dowel.
Drilling $\varnothing 10 \times 10$ mm.

H= 12 18

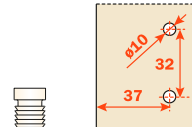

Series 200 mounting plates with traditional assembly

- For hinges Series 100, 200, 400, 600, 900, F, B, M and Silentia.
- Straight and cruciform mounting plates.
- Height adjustment ± 2 mm by cam.

Packing: heights 0, 2, 3 and 4
Boxes 600 pcs.
Pallets 14.400 pcs.

Packing: heights 6 and 9
Boxes 300 pcs.
Pallets 7.200 pcs.

B2P7E



Die-cast mounting plates.
Fixing: knock-in dowel.
Drilling $\varnothing 10 \times 11.5$.

H= 0 2 3

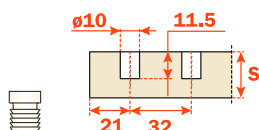

B2R3E



Die-cast mounting plates.
Fixing: wood screw.

B 3.5 DIN 7983.

H= 0 2 3 4 6 9

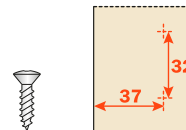

B2RGE



Die-cast mounting plates.
Fixing: Euroscrew.
Drilling $\varnothing 5 \times 11$ mm.

H= 0 2 3 4 6 9

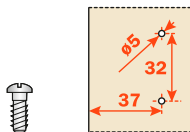

B2R7E



Die-cast mounting plates.
Fixing: knock-in dowel.
Drilling $\varnothing 10 \times 11.5$ mm.

H= 0 2 3 4 6 9

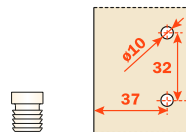

- For hinges Series 100, 200, 400, 600, 900, F, B and Silentia.
- Variable die-cast mounting plates for angled assembly from -7.5° to $+7.5^\circ$ and intermediate degrees, for special assemblies.
- An almost infinite variety of angle door applications is possible using variable-angle mounting plates in conjunction with one of Salice's range of angled-arm hinges.

Packing

Boxes 600 pcs.
Pallets 14.400 pcs.

B2V3BW9R



Die-cast mounting plates.
Fixing: wood screw.

B 3.5 DIN 7983.

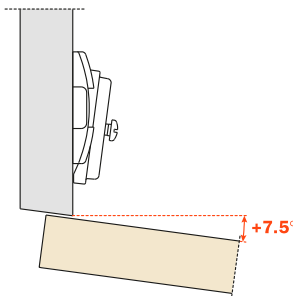

B2VGBW9R



Die-cast mounting plates.
Fixing: Euroscrew.
Drilling $\varnothing 5 \times 11$ mm.

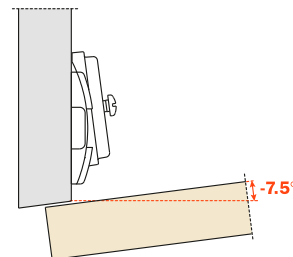

- For hinges Series 100, 200, 400, 600, 900, F, B and Silentia.
- Variable die-cast mounting plates for angled assembly from +10° to +30° and intermediate degrees, for special assemblies.
- An almost infinite variety of angle door applications is possible using variable-angle mounting plates in conjunction with one of Salice's range of angled-arm hinges.

Packing

Boxes 300 pcs.
Pallets 7.200 pcs.

B2V3BW9S



Die-cast mounting plates.
Fixing: wood screw.

B 3.5 DIN 7983.

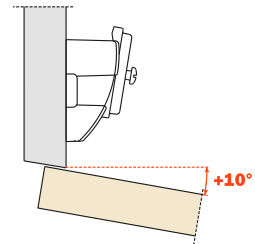

B2VGBW9S



Die-cast mounting plates.
Fixing: Euroscrew.
Drilling ø5x11 mm.

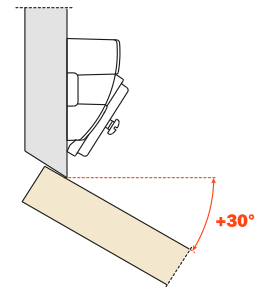

- Die-cast angled mounting plates for assembly at 15°. For hinges Series 100, 200, 400, 600, 900, F, B and Silentia.

Packing

Boxes 600 pcs.
Pallets 14.400 pcs.

B2V3BW9



Die-cast mounting plates.
Fixing: wood screw.

B 3.5 DIN 7983.

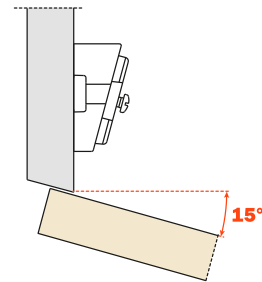

B2VGBW9



Die-cast mounting plates.
Fixing: Euroscrew.
Drilling ø5x11 mm.

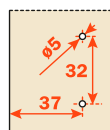

Series 200 mounting plates with traditional assembly

- Die-cast mounting plates for special assemblies. For hinges Series 100, 200, 400, 600, 900, F, B and Silentia.
- An almost infinite variety of angle door applications is possible using variable-angle mounting plates in conjunction with one of Salice's range of angled-arm hinges; from -45° to $+70^{\circ}$.

Variable-angle mounting plates for angled assembly from $+7.5^{\circ}$ to -7.5° and intermediate angles by adjusting the set screw indicated.

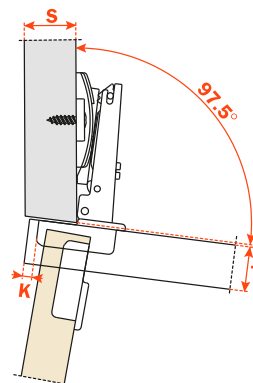
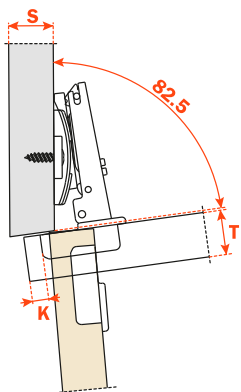

Assembly example from 82.5° to 97.5° angle.

Angled mounting plates for assembly at 15° .

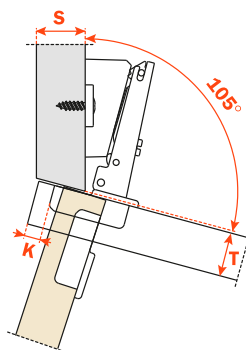

Assembly example with a 105° angle.

Variable-angle mounting plate for angled assembly from $+10^{\circ}$ to $+30^{\circ}$ and intermediate angles by adjusting the set screw indicated.

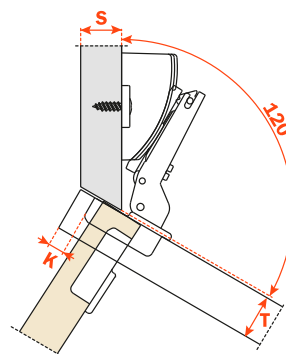
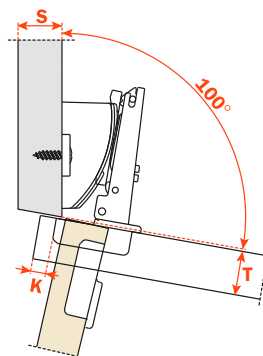

Assembly example from 100° to 120° angle.

Variable-angle adapters

Die-cast adapters for all mounting plates.

SAV354X9R

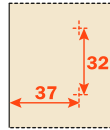

Die-cast adapter +5°. Fixing: wood screw.
B 3.5 DIN 7983.

SAV354X9S

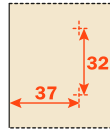

Die-cast adapter +10°. Fixing: wood screw.
B 3.5 DIN 7983.

Series 300 mounting plates



Series 300 mounting plates

- Asymmetrical cruciform mounting plates. For hinges Series 300.
- 20x32 mm drilling.
- Height adjustment $\pm 1,5$ mm by cam.

Packing mounting plates

Boxes 600 pcs.
Pallets 14.400 pcs.

Packing spacers for mounting plates

Boxes 300 pcs.
Pallets 7.200 pcs.

B383E09



Steel mounting plates.
Fixing: wood screw.

B 3.5 DIN 7983.

H= 0

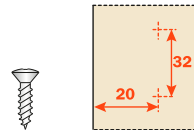

B383E69



Steel mounting plates.
Fixing: wood screw.

B 3.5 DIN 7983.

H= 6

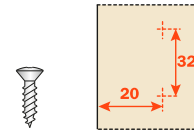

S38X8639



3 mm spacer for special applications.

S38X86D9



13 mm spacer for special applications.

Smove





Smove is the innovative system used to soften the closing action of any door.

It can be installed to all cabinet applications and offers optimal performance.

D0S_SNG - Smoveholder



We suggest that one Smoveholder only is used for each door, by selecting one of the three available models:



D0S7SNG

to be used with **doors made with particularly light materials.**



D0S8SNG

to be used with **doors with two hinges.**



D0S9SNG

to be used with **doors with more than two hinges.**

Packing

Boxes 300 pcs
Pallets 7.200 pcs

Adapter for hinges with arm 0



Adapter to be used **ONLY** with cruciform mounting plates 37x 32 mm.
For use with mounting plates to be fixed with wood screw, please use a screw with screwhead \varnothing 8 mm and length 16 mm.

D2VX09 - for steel mounting plates

DARX09 - for die-cast mounting plates

Packing

Boxes 300 pcs
Pallets 7.200 pcs

Adapter for hinges with arm 5



Adapter to be used **ONLY** with cruciform mounting plates 37x 32 mm.
For use with mounting plates to be fixed with wood screw, please use a screw with screwhead \varnothing 8 mm and length 16 mm.

D2VX59 - for steel mounting plates

DARX59 - for die-cast mounting plates

Packing

Boxes 300 pcs
Pallets 7.200 pcs

Adapter for hinges with arm 9



Adapter to be used **ONLY** with cruciform mounting plates 37x 32 mm.
For use with mounting plates to be fixed with wood screw, please use a screw with screwhead \varnothing 8 mm and length 16 mm.

D2VX99 - for steel mounting plates

DARX99 - for die-cast mounting plates

Packing

Boxes 300 pcs
Pallets 7.200 pcs

Adapter for hinges with arm 17



Adapter to be used **ONLY** with cruciform mounting plates 37x 32 mm.
For use with mounting plates to be fixed with wood screw, please use a screw with screwhead \varnothing 8 mm and length 16 mm.

D2VXP9 - for steel mounting plates





DARXP9 - for die-cast mounting plates

Packing

Boxes 150 pcs
Pallets 3.600 pcs

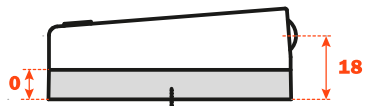
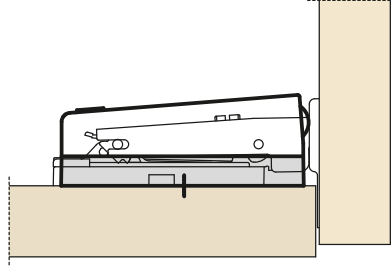
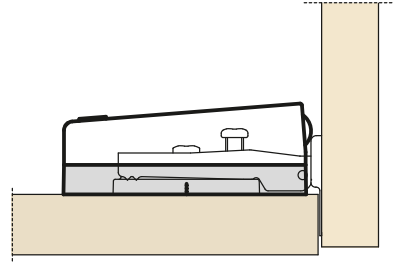
Smove - D0S_SNG - Choice of the adapter

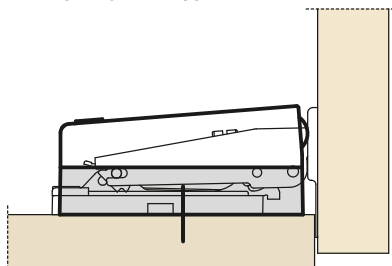
Smove works by bearing against the flange of the hinge cup and for this reason it is necessary to choose the appropriate adapter. By reducing the door overlay, it is necessary consequently to increase the height of the adapter.

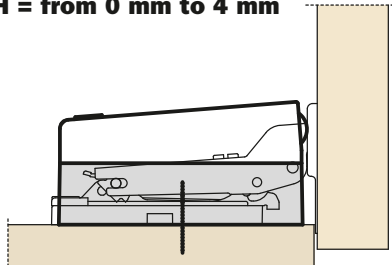
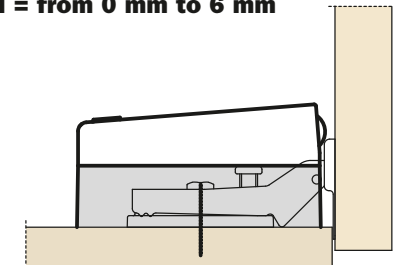
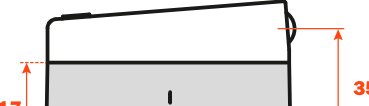
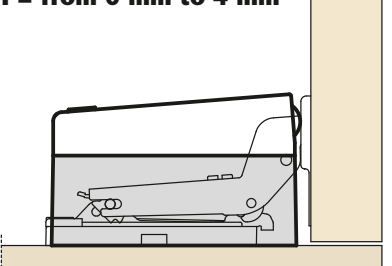
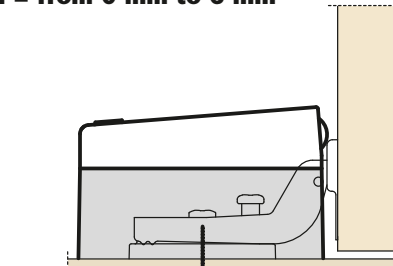
	FOR HINGES SERIES 100, 200, 800 AND 900	FOR HINGES SERIES 400 AND 600
ADAPTER HEIGHT = 0 	For mounting plates H = from 0 mm to 4 mm 	For mounting plates H = from 0 mm to 6 mm 
ADAPTER HEIGHT = 5 	For mounting plates H = from 0 mm to 4 mm 	
ADAPTER HEIGHT = 9 	For mounting plates H = from 0 mm to 4 mm 	For mounting plates H = from 0 mm to 6 mm 
ADAPTER HEIGHT = 17 	For mounting plates H = from 0 mm to 4 mm 	For mounting plates H = from 0 mm to 6 mm 

FOR HINGES SERIES F

FOR HINGES SERIES B

The required overlay can be achieved not only by using the appropriate hinge arm, but also by using mounting plates of different heights.

Application examples:

For mounting plates
H = from 0 mm to 3 mm

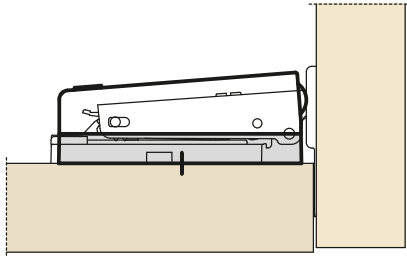

Arm 0
For mounting plates
H = from 6 mm to 9 mm

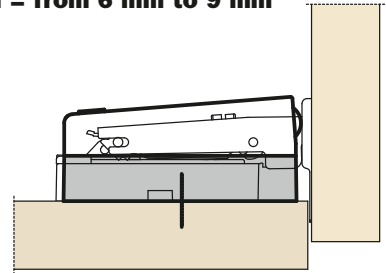

For mounting plates
H = from 0 mm to 3 mm

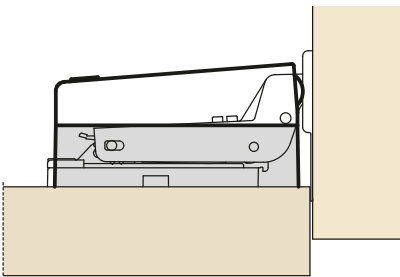

For mounting plates
H = from 0 mm to 4 mm

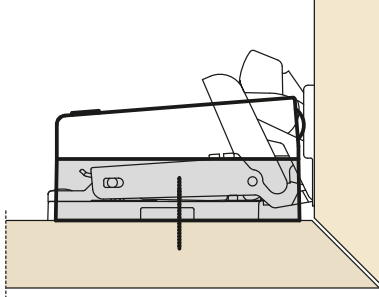

Arm 0
For mounting plates
H = from 9 mm to 12 mm

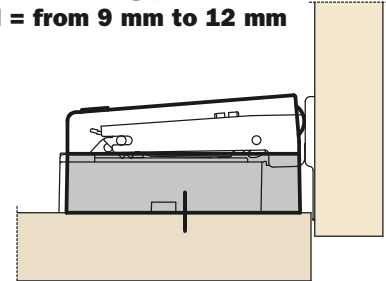

For mounting plates
H = 0 mm

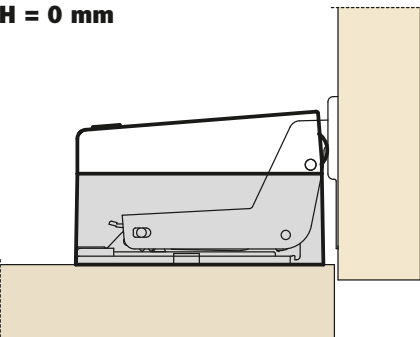

Arm 0
For mounting plates
H = 18 mm

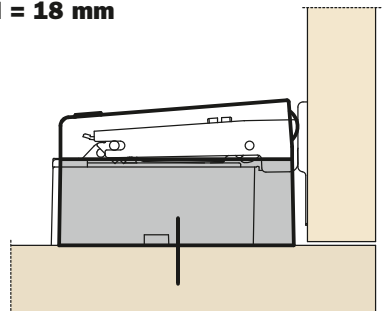

1 - Loosen one of the two fixing screws of the mounting plate.



2 - Insert the adapter for the Smoveholder.



3 - Retighten the fixing screw of the mounting plate.



4 - Apply the Smoveholder to the adapter, as indicated.



5 - Finally it is possible to adjust the Smove to increase or reduce the decelerating effect.



Positive adjustment

Rotating the screw towards the + sign, thus moving the Smove forward, the decelerating effect increases.



Negative adjustment

Rotating the screw towards the - sign, thus moving the Smove backwards, the decelerating effect reduces.





D0L_SNG - Smoveholder with assembly stop devices



We suggest that one smoveholder only is used for each door, by selecting one of the three available models:



D0L7SNG
to be used with **doors made with particularly light materials.**



D0L8SNG
to be used with **doors with two hinges.**



D0L9SNG
to be used with **doors with more than two hinges.**

Packing

Boxes 150 pcs
Pallets 13.500 pcs

D0L_SNGR - Smoveholder without assembly stop devices



We suggest that one smoveholder only is used for each door, by selecting one of the three available models:



D0L7SNGR
to be used with **doors made with particularly light materials.**



D0L8SNGR
to be used with **doors with two hinges.**



D0L9SNGR
to be used with **doors with more than two hinges.**

Packing

Boxes 150 pcs
Pallets 13.500 pcs

Smoveholder application

Arm 0, Arm 5, Arm 9 - Smoveholder DOL_SNG

Frontal positioning: with assembly stop devices.
 Side positioning: place the smoveholder with its wing in contact with the side of the cabinet.

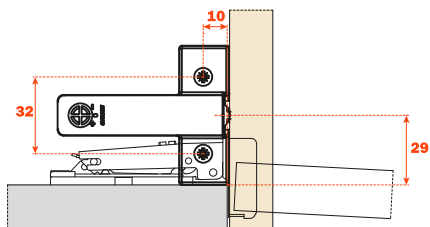

Arm 17 - Smoveholder DOL_SNGR

Frontal positioning: drilling value at + 11 mm plus the door thickness.
 Side positioning: place the smoveholder with its centreline approx. 5 mm from the edge of the door at its fully open position.

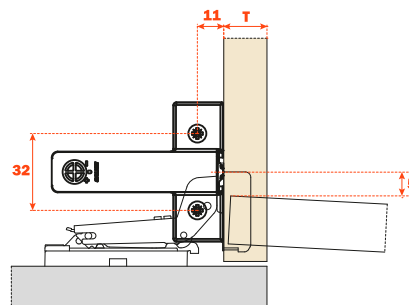

1 - Place the smoveholder in position on the top or bottom panel with its wing in contact with the side of the cabinet.

2 - Screw the smoveholder into position.



3 - Finally it is possible to adjust the Smove to increase or reduce the decelerating effect.



Positive adjustment

Rotating the screw towards the + sign, thus moving the Smove forward, the decelerating effect increases.

Negative adjustment

Rotating the screw towards the - sign, thus moving the Smove backwards, the decelerating effect reduces.



1 - Apply Smove to the hinge arm

2 - Fix Smove as indicated

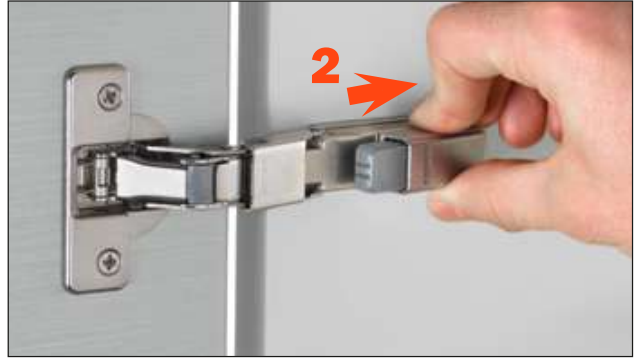
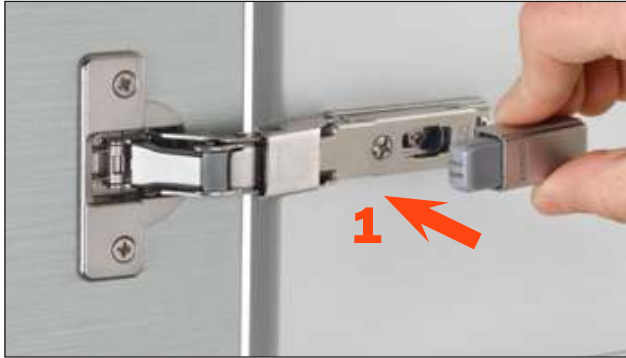

D005SNG



Smove

Packing

Boxes 250 pcs.
Cartons 2.000 pcs.

D005SNB



Smove

Packing

Boxes 250 pcs.
Cartons 2.000 pcs.

Technical information about the installation of SMOVE D005SN to be recessed

Insert Smove D005 into the cabinet side opposite the hinges. For an optimal performance, we suggest that Smove D005 is positioned at the centre of the side panel.

It is suggested for doors from 450 mm to 600 mm width.

For wood-based and alu-framed doors over 1600 mm height, it may be necessary to use two Smove, one to be inserted into the upper part and the second into the lower part of the cabinet side opposite the hinges.



Smove - D006SN

D006SNG



Smove

Packing

Boxes 250 pcs.
Cartons 2.000 pcs.

D006SNB



Smove

Packing

Boxes 250 pcs.
Cartons 2.000 pcs.

Technical information about the installation of SMOVE D006SN to be recessed

Insert Smove D006 at the centre of the top or the base panel of the cabinet.

For wood-based and alu-framed doors over 1600 mm height, it may be necessary to use two Smove, one to be inserted into the top and the second into the base panel of the cabinet.



D008SNG



Smove

Packing

Boxes 250 pcs.
Cartons 2.000 pcs.

D008SNB



Smove

Packing

Boxes 250 pcs.
Cartons 2.000 pcs.

Technical information about the installation of SMOVE D008SN to be recessed

Insert Smove D008 into the top or the base panel of the cabinet on the hinged side.

A drilling distance of 27 mm from the cabinet side is suggested.

For doors over 1600 mm height, it may be necessary to use two Smove, one to be inserted into the top and the second into the base panel of the cabinet.



D009SNG



Smove

Packing

Boxes 250 pcs.
Cartons 2.000 pcs.

D009SNB



Smove

Packing

Boxes 250 pcs.
Cartons 2.000 pcs.

Technical information about the installation of SMOVE D009SN to be recessed

Insert Smove D009 into the base panel of the cabinet on the hinged side.

Smove D009 is used for doors between 720 mm and 1600 mm high.

Drilling distance from the cabinet side:

- for hinges with **arm 0** mm the drilling distance equals **15 mm** plus the base height;
- for hinges with **arm 5** mm the drilling distance equals **20 mm** plus the base height;
- for hinges with **arm 9** mm the drilling distance equals **24 mm** plus the base height.



D010SNG



Smove

Packing

Boxes 250 pcs.
Cartons 2.000 pcs.

D010SNB



Smove

Packing

Boxes 250 pcs.
Cartons 2.000 pcs.

Technical information about the installation of SMOVE D010SN to be recessed

Insert Smove D010 into the base panel of the cabinet on the hinged side.

Smove D010 is used for doors over 1600 mm high.

Drilling distance from the cabinet side:

- for hinges with **arm 0** mm the drilling distance equals **15 mm** plus the base height;
- for hinges with **arm 5** mm the drilling distance equals **20 mm** plus the base height;
- for hinges with **arm 9** mm the drilling distance equals **24 mm** plus the base height.



To be recessed - Assembly instructions

Drill a hole \varnothing 10 mm and min. 50 mm depth in the cabinet.
Insert Smove into the hole.



Technical information about the installation of SMOVE with adapter



SMOVE D005 can be fitted using:

- 1) adapters to be screw-fixed to the cabinet side (see pages 265 and 266);
- 2) adapters with double sided adhesive system (see page 268).

It is suggested for doors from 450 mm to 600 mm width.

For wood-based and alu-framed doors over 1600 mm height, it may be necessary to use two Smove, one to be fixed to the upper part and the second to the lower part of the cabinet side opposite the hinges.

SMOVE D006 can be fitted using:

- 1) adapters to be screw-fixed to the top or bottom panel of the cabinet (see pages 265 and 266);
- 2) adapters with double sided adhesive system (see page 268).

For wood-based and alu-framed doors over 1600 mm height, it may be necessary to use two Smove, one to be fixed to the top and the second to the base panel of the cabinet.



SMOVE D008 can be fitted using:

- 1) adapters to be screw-fixed to the top or bottom panel of the cabinet (see pages 265 and 266); Smove should be positioned at a distance of 27 mm from the inside face of the cabinet side. If using cruciform adapters, the correct position is located by moving the adapters so that one wing is in contact with the inside face of the cabinet.
- 2) adapters with double sided adhesive system (see page 268).

For doors over 1600 mm height, it may be necessary to use two Smove, one to be fixed to the top and the second to the base panel of the cabinet.

- 3) adapters to be screw-fixed to the inside of the cabinet door (see page 270).

D008 is used for doors up to 720 mm high.



SMOVE D009 and D010 can be fitted using:

- 1) longitudinal adapters to be screw-fixed to the base panel of the cabinet (see pages 265 and 266);
- 2) adapters to be screw-fixed to the inside of the cabinet door (see page 270).

D009 is used for doors between 720 mm and 1600 mm high.

D010 is used for doors over 1600 mm high.

Adapters to be screw fixed to the cabinet

D063SNXR

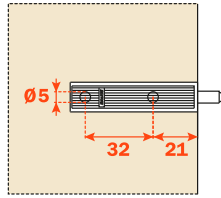

D063SNGR = grey
D063SNBR = beige

Longitudinal plastic adapter.
To be fixed with dowels.
Without assembly stop device.

Packing
Boxes 500 pcs.
Pallets 12.000 pcs.

D064SNXN

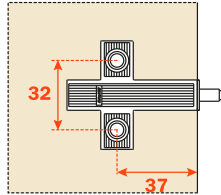

D064SNGN = grey
D064SNBN = beige

Cruciform plastic adapter.
To be fixed with wood screws.
37x32 mm drilling.
With assembly stop device.

Packing
Boxes 500 pcs.
Pallets 12.000 pcs.

D064SNXR

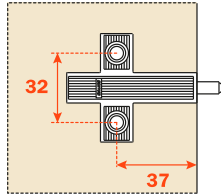

D064SNGR = grey
D064SNBR = beige

Cruciform plastic adapter.
To be fixed with wood screws.
37x32 mm drilling.
Without assembly stop device.

D065SNGR = grey - to be fixed with Euro screws.
D065SNBR = beige - to be fixed with Euro screws.

Packing
Boxes 500 pcs.
Pallets 12.000 pcs.

D060SNXN

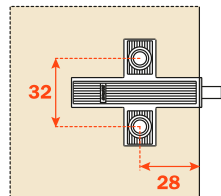

D060SNGN = grey
D060SNBN = beige

Cruciform plastic adapter.
To be fixed with wood screws.
28x32 mm drilling.
With assembly stop device.

Packing
Boxes 500 pcs.
Pallets 12.000 pcs.

D060SNXR

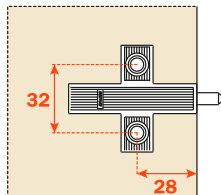

D060SNGR = grey
D060SNBR = beige

Cruciform plastic adapter.
To be fixed with wood screws.
28x32 mm drilling.
Without assembly stop device.

Packing
Boxes 500 pcs.
Pallets 12.000 pcs.

D066SNXN

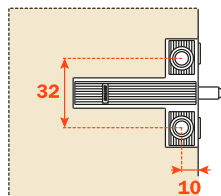

D066SNGN = grey
D066SNBN = beige

Cruciform plastic adapter.
To be fixed with wood screws.
10x32 mm drilling.
With assembly stop device.

Packing
Boxes 500 pcs.
Pallets 12.000 pcs.

Smove - Adapters to be screw fixed to the cabinet

D070SNXN

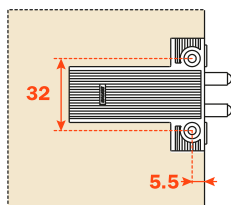

D070SNGN = grey
D070SNBN = beige

Double cruciform plastic.
To be fixed with wood screws.
5.5x32 mm drilling.
With assembly stop device.

Packing

Boxes 500 pcs.
Pallets 12.000 pcs.

D070SNXR

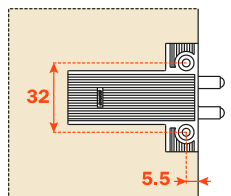

D070SNGR = grey
D070SNBR = beige

Double cruciform plastic.
To be fixed with wood screws.
5.5x32 mm drilling.
Without assembly stop device.

Packing

Boxes 500 pcs.
Pallets 12.000 pcs.

D076XX9R

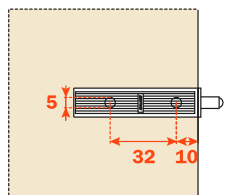

Longitudinal die-cast adapter.
To be fixed with wood screws.
Without assembly stop device.

Cover caps to be ordered
separately.

D077XX9R - to be fixed with Euroscrews.

Packing

Boxes 500 pcs.
Pallets 12.000 pcs.

D076SN9

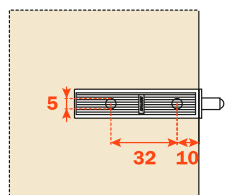

Longitudinal die-cast adapter.
To be fixed with wood screws.
With assembly stop device.

Cover caps to be ordered
separately.

D077SN9 - to be fixed with Euroscrews.

Packing

Boxes 500 pcs.
Pallets 12.000 pcs.

Adapter with assembly stop device

Insert Smove into the adapter. Place the adapter in the position in the cabinet appropriate to the version of Smove to be installed, using the assembly stop device for final positioning.



Adapter without assembly stop device

Insert Smove into the adapter. Place the adapter in the position in the cabinet appropriate to the version of Smove to be installed, based on the dimensions indicated for the type of adapter.



D051SNX



D051SNG = grey
D051SNB = beige

Longitudinal plastic.
With assembly stop device.

Packing
Boxes 500 pcs.
Pallets 12.000 pcs.

D086SNX



D086SNG = grey
D086SNB = beige

Longitudinal plastic with
additional fixing screw.
To be fixed with double sided
adhesive system.
It is suggested to fix the adapter
with the included screw.
For application with full
overlay door.
With assembly stop device

Packing
Boxes 500 pcs.
Pallets 12.000 pcs.

D087SNX



D087SNG = grey
D087SNB = beige

Longitudinal plastic with
additional fixing screw.
To be fixed with double sided
adhesive system.
It is suggested to fix the adapter
with the included screw.
For application with full and half
overlay door.
With assembly stop device.

Packing
Boxes 500 pcs.
Pallets 12.000 pcs.

With adapter to be fixed with double sided adhesive system - Assembly instructions

For a correct application and to ensure optimal endurance, we suggest these guidelines are followed:

- 1) clean and de-grease the cabinet surface where the adapter is to be installed using an acetone based cleaner;
- 2) remove the protective strip from the adhesive;
- 3) place the adapter in position and apply a firm pressure for about one minute;
- 4) insert Smove frontally into the adapter;
- 5) allow a period of 12 hours to elapse before subjecting the product to continuous usage.

As an option for additional security, the adapters D086SNX and D087SNX can be fixed with the included wood screw.

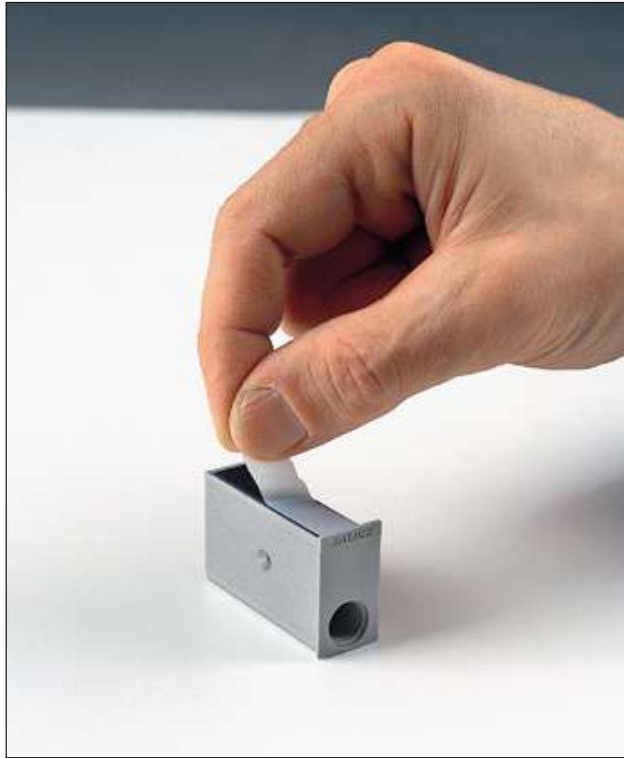

Smove - Adapter to be screw fixed to the door

D078XX9

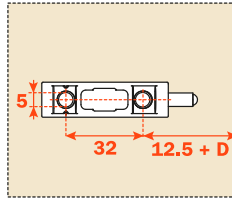

Longitudinal inclined die-cast adapter.
To be fixed with wood screws or Euroscrews.
Without assembly stop device.
It is suggested that the adapter is positioned near the centre of the height of the door.

Packing
Boxes 500 pcs.
Pallets 12.000 pcs.

Installation of Smove with adapter to be screw fixed to the door. Assembly instructions.

Insert Smove frontally into the adapter.

It is suggested that the adapter is positioned near the centre of the height of the door.



Sliding system for concertina doors



Sliding system for concertina doors - Technical features

The Salice system for concertina doors has been designed to open both doors on one side only, giving good access to the interior of the cabinet.
Space taken up by the door in the maximum open position is reduced to a minimum (approximately 80 mm).



A nylon strip is available in order to prevent insertion of objects or fingers between doors. This also makes the system dustproof.



To ensure that the door closes fully and securely, particularly when there is some curvature of the door, a locating device is available.



F1C169



Hinge for sliding block

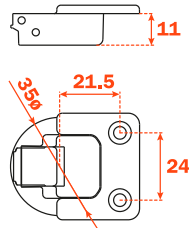

Central hinge



F1CXE9
screw-on

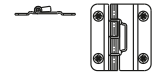

F1C0E9

knock-in
Dowels \varnothing 8x11.5

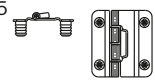

F1CZ69



For aluminium-framed doors

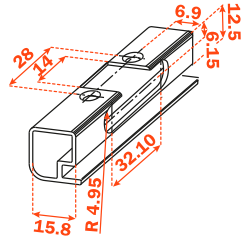

D206BK5

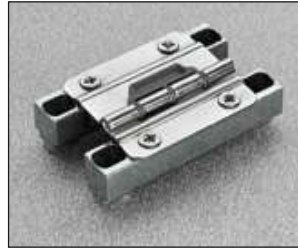

Central hinge for the Practical system of aluminium-framed doors.

PracticAL

F1C069



Hinge for the Practical system of aluminium-framed doors

PracticAL

Adhesive finger-protection strip



F1SBAY neutro

F1PVAY



Long sliding block
For aluminium-framed doors

F1RFAY



Locating device for door

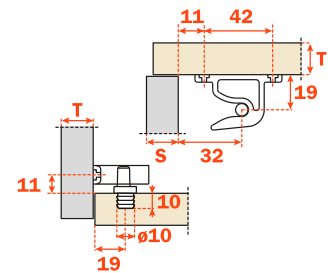

F1PXAY



Sliding block

Calibrated height adjustment

Height adjustment of hinges assembled with the sliding components is achieved through a cam. Through this alignment a parallel movement of the component in the track is achieved. The result is a smooth movement without any binding.

ATTENTION! The sliding block does not have a load-bearing function. Therefore it must slide freely inside the track.

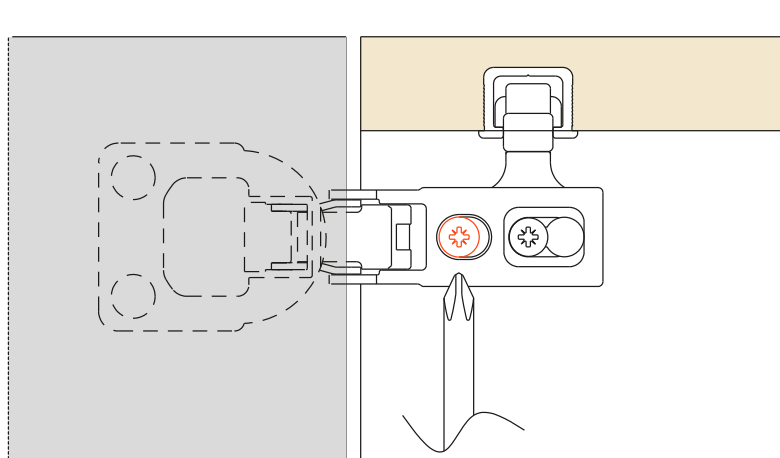
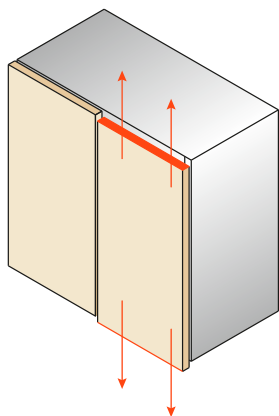

+2 mm -2 mm



Depth adjustment

Depth adjustment of the hinges mounted on the sliding component is achieved through the fixing screw of the same hinge.

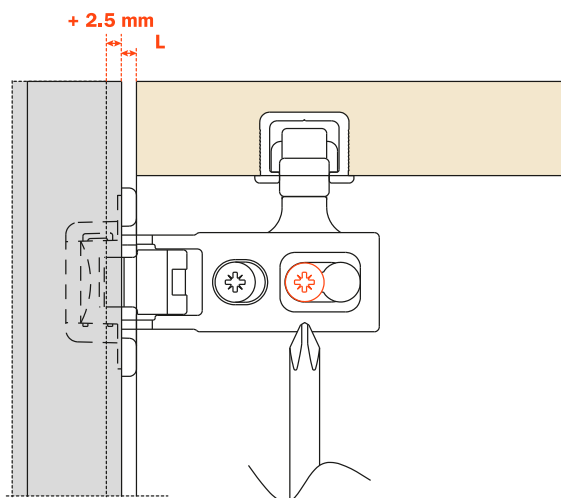
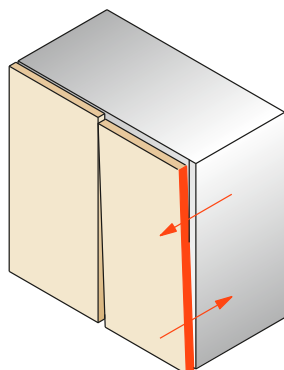
Depth adjustment should be made in conjunction with the hinges mounted on the opposite door. This adjustment is useful to keep the "L" value constant all along front of the furniture.

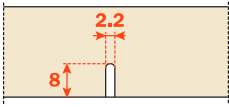
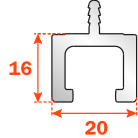

+2.5 mm

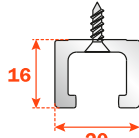
	barb-fixed	screw-on B 3.5 DIN 7982
	 	 
Colours		
white	F1GIA1	F1GFA1
black	F1GIA3	F1GFA3
grey	F1GIAG	F1GFAG
beige	F1GIAP	F1GFAP

Standard lengths available: 590 mm, 880 mm, 1180 mm. Non-standard lengths can be supplied subject to a minimum order quantity of 900 pieces. The required length should be expressed in millimetres in the last four digits of the product code occupied by the dashes.

Mount the hinges of the fixed door on to the mounting plates on the cabinet side.
We recommend the use of Salice hinge part number C2A6A99 110° with BAR3R mounting plate or similar.



Position the sliding block inside the track by rotating it 90°.

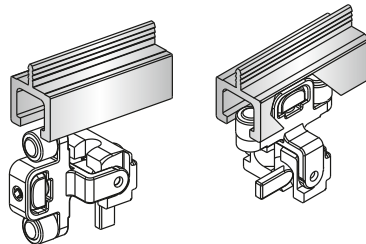

Lock the sliding block into position by turning the marked in orange lever.

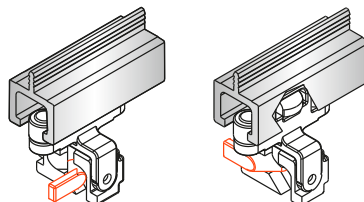

Application into the top of the cabinet and doors Solution with plastic track barb-fixed or screw-fixed

Drilling distances without finger-protection strip

To facilitate the assembly of the doors on the cabinet, it is preferable to premount all the hinges.

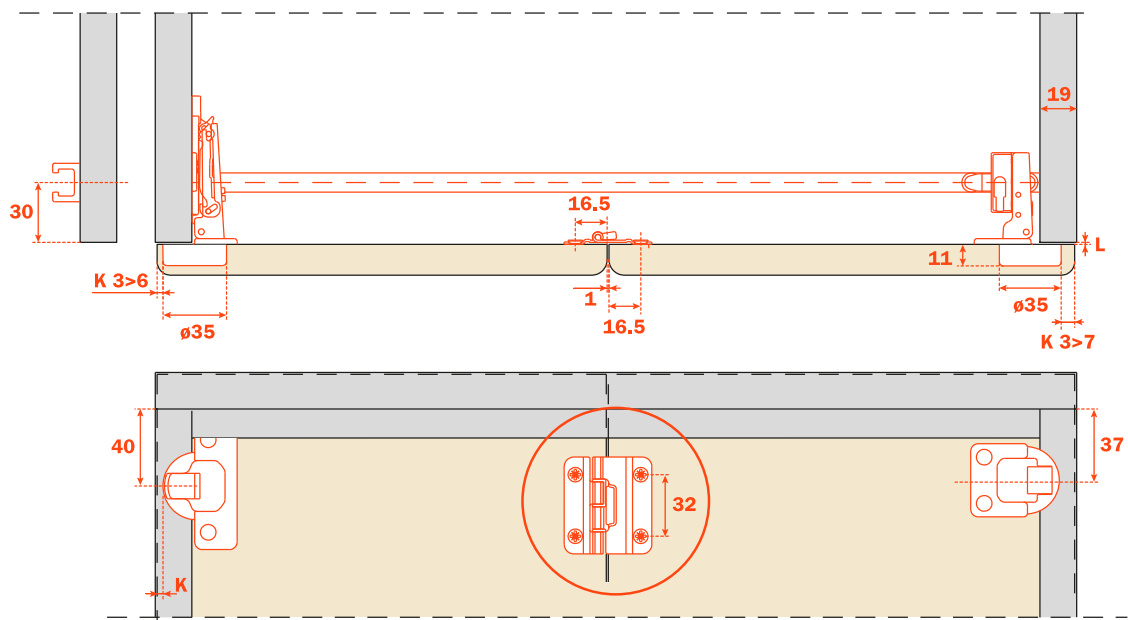

Central assembly:
 - narrow part to be mounted on the door which is fixed to the cabinet side;
 - wider part to be mounted on the moving door.

Drilling distances with finger-protection strip

To facilitate the assembly of the doors on the cabinet, it is preferable to premount all the hinges.

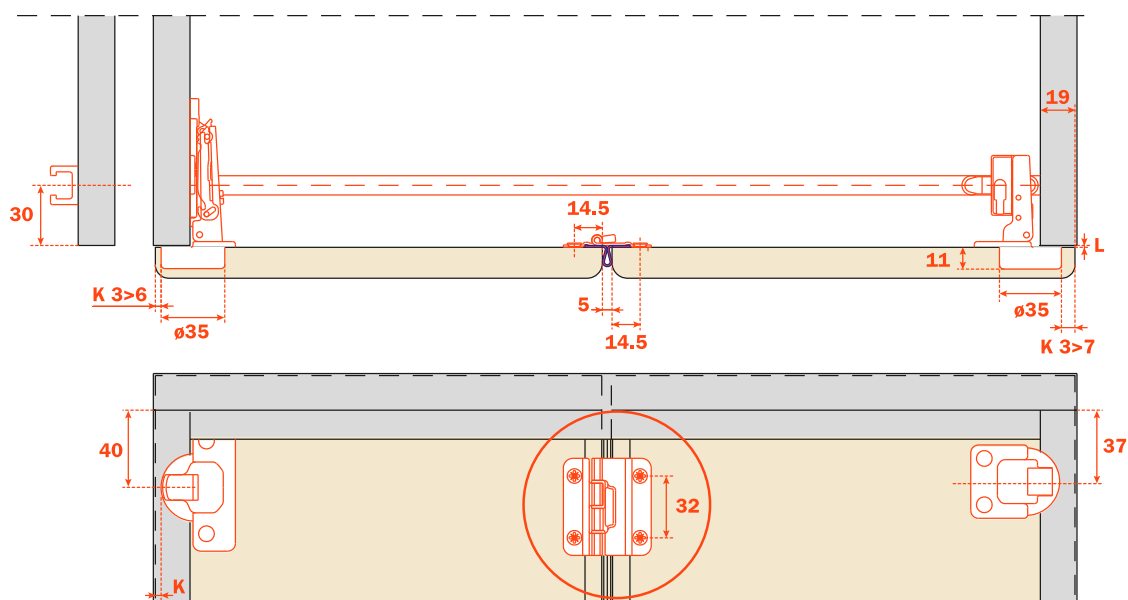

Central assembly:
 - narrow part to be mounted on the door which is fixed to the cabinet side;
 - wider part to be mounted on the moving door.

**Application into the top of the cabinet and doors.
Solution with plastic track barb-fixed or screw-fixed.**

**Glass doors with aluminium-frame
Drilling distances without finger-protection strip and with long sliding block**

To facilitate the assembly of the doors on the cabinet, it is preferable to premount all the hinges.

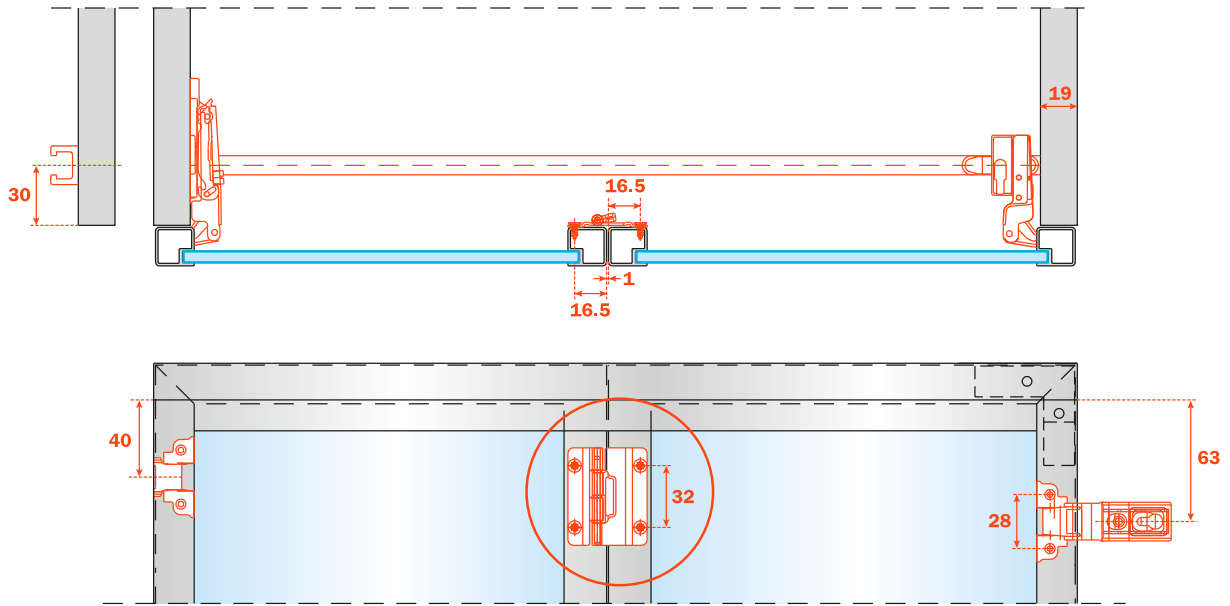

Central assembly:
- narrow part to be mounted on the door which is fixed to the cabinet side;
- wider part to be mounted on the moving door.

**Glass doors with aluminium frame
Drilling distances with finger-protection strip and long sliding block**

To facilitate the assembly of the doors on the cabinet, it is preferable to premount all the hinges.

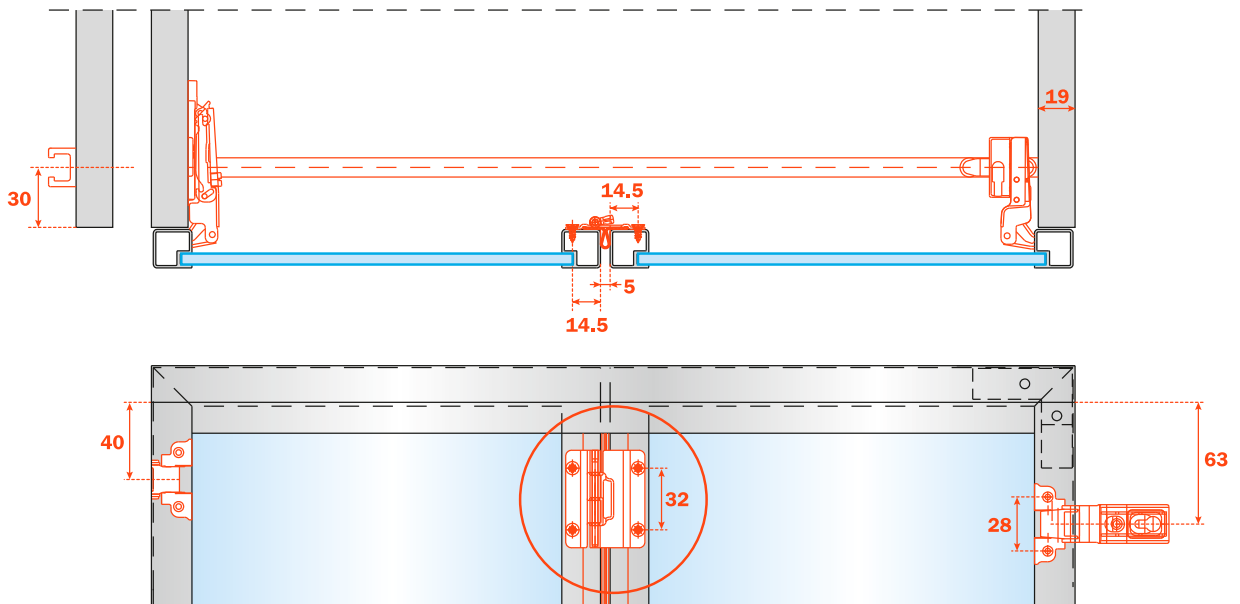

Central assembly:
- narrow part to be mounted on the door which is fixed to the cabinet side.
- wider part to be mounted on the moving door.

Application into the top of the cabinet and doors
Solution with barb-fix and screw-fix plastic track

Glass doors with the Practical system of aluminium-framed doors

Distance to be used when finger-protection strip and two-screw (D206BS5) or four-screw (D206BS5L) corner joint are used

To facilitate the assembly of the doors on the cabinet, it is preferable to premount all the hinges.

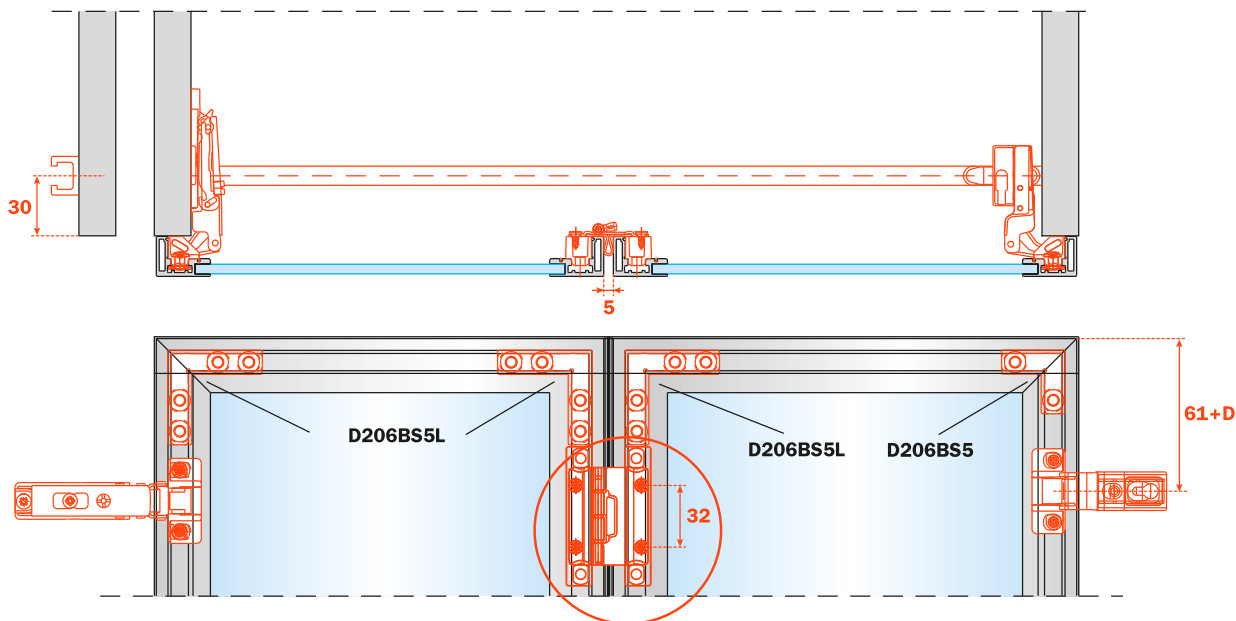

Central assembly:
 - narrow part to be mounted on the door which is fixed to the cabinet side;
 - wider part to be mounted on the moving door.

Glass doors with the Practical system of aluminium-framed doors

Distance to be used when finger-protection strip and four-screw corner joint (D206BS5L) are used

To facilitate the assembly of the doors on the cabinet, it is preferable to premount all the hinges.

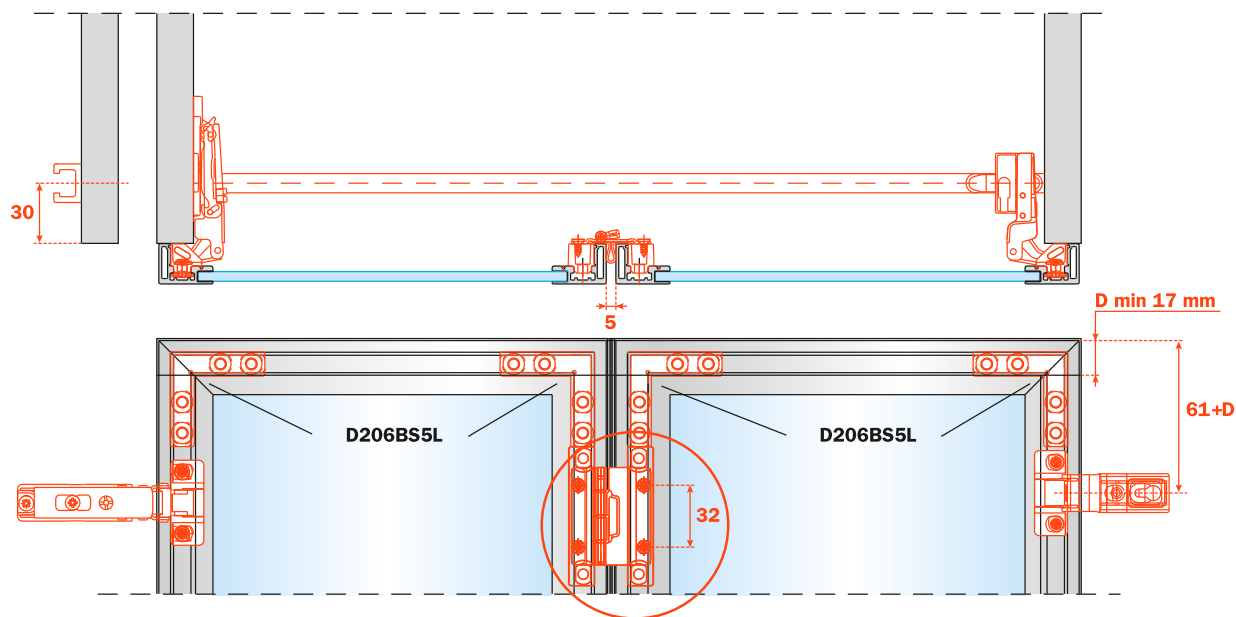

Central assembly:
 - narrow part to be mounted on the door which is fixed to the cabinet side;
 - wider part to be mounted on the moving door.

Packaging (standard packaging)

Elements of the system	Boxes	Pallets
F1C169	300 pcs.	7.200 pcs.
F1PXAY	300 pcs.	7.200 pcs.
F1CXE9	600 pcs.	14.400 pcs.
F1COE9	600 pcs.	14.400 pcs.
F1RFAY	300 pcs.	7.200 pcs.
F1CZ69	300 pcs.	7.200 pcs.
F1CA69	300 pcs.	7.200 pcs.
F1PVAY	300 pcs.	7.200 pcs.
F1C069	300 pcs.	7.200 pcs.
Adhesive finger-protection strip	200 metres	
Tracks 880 mm - 1180 mm	75 pcs.	
Tracks 590 mm	150 pcs.	

KIT - Packaging

F1C169	25 pcs.
F1PXAY	25 pcs.
F1CXE9	75 pcs.
F1GFA.....	25 pcs.
Available in 3 lengths	
and 4 colours	

Code number composition (example)

F1KFX3X880

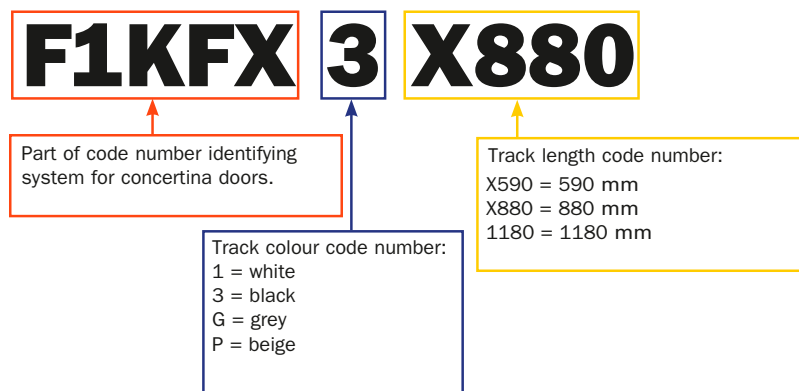

Lift - Opening systems - Flap door



Lift - Opening systems
Flap door





Part number composition

- F** = Lifting system
- R2** = Flap door opening
- D/S** = Right or left versions
- XXXX** = Special options
- SN** = Cover with Salice logo / **99** = Cover with arrangement for screw cover cap
- X** = Colour of the cover
- X1** = Cover with silk-screen printed logo

FR2X**XXXX**S**N**X

↑

D = right version
S = left version

↑

G = grey cover
1 = white cover
9 = nickel-pl. cover



FR2XXXXX999

Part number for Lift system supplied with nickel-plated cover with arrangement for screw cover cap.

Screw cover cap to be ordered separately.



FR2XXXXX_ _9X1

Part number for Lift system supplied with nickel-plated cover with silk-screen printed logo.

Lift - Opening systems - Flap door



Components of the system for wooden door



FR2DXXXXSNX
Lifting system - **right** side

Cover

Colour of the cover:

G = grey
1 = white
9 = nickel-pl.

Packing
Boxes 12 pcs.



FR2SXXXXSNX
Lifting system - **left** side

Cover

Colour of the cover:

G = grey
1 = white
9 = nickel-pl.

Packing
Boxes 12 pcs.

To be ordered separately:

C2_6A99



Hinge for door.
See page 290 to complete the part number with the available fixing systems.

Packing
Boxes 300 pcs.

BAPGR39



Mounting plate for the top of the wall cabinet.

Mounting plate for door.

Packing
Boxes 300 pcs.

FLMGSE XXX ← Fill with the required piston strength



Gas piston.
See page 296 and 297 to complete the part number with the appropriate piston strength.

Packing
Boxes 12 pcs.

D00SSNG



Smove

For doors of small weight and dimensions.

Packing
Boxes 250 pcs.

FLMGRE XXX ← Fill with the required piston strength



Progressive gas piston.
See page 298 and 299 to complete the part number with the appropriate piston strength.

Packing
Boxes 12 pcs.

D00FSNG



Smove

For doors of middle weight and dimensions.

Packing
Boxes 250 pcs.

D00LSNG



Smove

For doors of large weight and dimensions.

Packing
Boxes 250 pcs.



Components of the system for alu-framed door



FR2DXXXXSNX
Lifting system - **right** side

Cover

Colour of the cover:

G = grey
1 = white
9 = nickel-pl.

Packing

Boxes 12 pcs.



FR2SXXXXSNX
Lifting system - **left** side

Cover

Colour of the cover:

G = grey
1 = white
9 = nickel-pl.

Packing

Boxes 12 pcs.

To be ordered separately:

C2Z6A99

Hinge for door



Packing

Boxes 150 pcs.

BAP_R39



BAPGR39

Mounting plate for the top of the wall cabinet.

BAP3R39

Mounting plate for door.

Packing

Boxes 300 pcs.

FLMGSE XXX ← Fill with the required piston strength



Gas piston.
See page 296 and 297 to complete the part number with the appropriate piston strength.

Packing

Boxes 12 pcs.

D00SSNG



Smove

For doors of small weight and dimensions.

Packing

Boxes 250 pcs.

FLMGRE XXX ← Fill with the required piston strength



Progressive gas piston.
See page 298 and 299 to complete the part number with the appropriate piston strength.

Packing

Boxes 12 pcs.

D00FSNG



Smove

For doors of middle weight and dimensions.

Packing

Boxes 250 pcs.

DLZXBH9

Support for plate with fixing screws.



Packing

Boxes 150 pcs.

D00LSNG



Smove

For doors of large weight and dimensions.

Packing

Boxes 250 pcs.

Lift - Opening systems - Flap door



Components of the system for wooden door with Push opening



FR2DXXXXSNX

Lifting system - **right** side

Cover

Colour of the cover:

G = grey
1 = white
9 = nickel-pl.

Packing

Boxes 12 pcs.



FR2SXXXXSNX

Lifting system - **left** side

Cover

Colour of the cover:

G = grey
1 = white
9 = nickel-pl.

Packing

Boxes 12 pcs.

To be ordered separately:

C2_PA99



Hinge for door.
See page 290 to complete the part number with the available fixing systems.

Packing

Boxes 300 pcs.

BAPGR39



Mounting plate for the top of the wall cabinet.
Mounting plate for door.

Packing

Boxes 300 pcs.

FLMGSE XXX ← Fill with the required piston strength



Gas piston.
See page 296 and 297 to complete the part number with the appropriate piston strength.

Packing

Boxes 12 pcs.

D00PSNA



Smove

Packing

Boxes 250 pcs.

FLMGRE XXX ← Fill with the required piston strength



Progressive gas piston.
See page 298 and 299 to complete the part number with the appropriate piston strength.

Packing

Boxes 12 pcs.



Components of the system for alu-framed door with Push opening



FR2DXXXXSNX

Lifting system - **right** side

Cover

Colour of the cover:

G = grey
1 = white
9 = nickel-pl.

Packing

Boxes 12 pcs.



FR2SXXXXSNX

Lifting system - **left** side

Cover

Colour of the cover:

G = grey
1 = white
9 = nickel-pl.

Packing

Boxes 12 pcs.

To be ordered separately:

C2ZPA99

Hinge for door.



Packing

Boxes 150 pcs.

BAP_R39



BAPGR39

Mounting plate for the top of the wall cabinet.

BAP3R29

Mounting plate for door.

Packing

Boxes 300 pcs.

FLMGSE XXX ← Fill with the required piston strength



Gas piston.
See page 296 and 297 to complete the part number with the appropriate piston strength.

Packing

Boxes 12 pcs.

D00PSNA



Smove

Packing

Boxes 250 pcs.

FLMGRE XXX ← Fill with the required piston strength



Progressive gas piston.
See page 298 and 299 to complete the part number with the appropriate piston strength.

Packing

Boxes 12 pcs.

DLZXBH9



Support for plate with fixing screws.

Packing

Boxes 150 pcs.

Lift - Opening systems - Flap door

The door can be opened with or without a handle. If a handle is used, it can be positioned anywhere on the door. Alternatively, for doors up to 400 mm in height that are not fitted with a handle for aesthetic reasons, the Push self-opening system can be used.



Push with depth and sideways adjustment

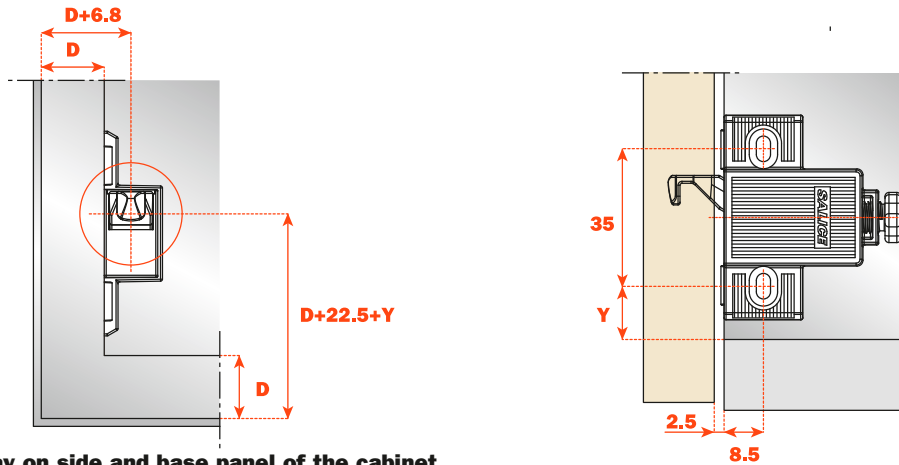

D = Door overlay on side and base panel of the cabinet
Y = min. 8.5 mm

Push without adjustment

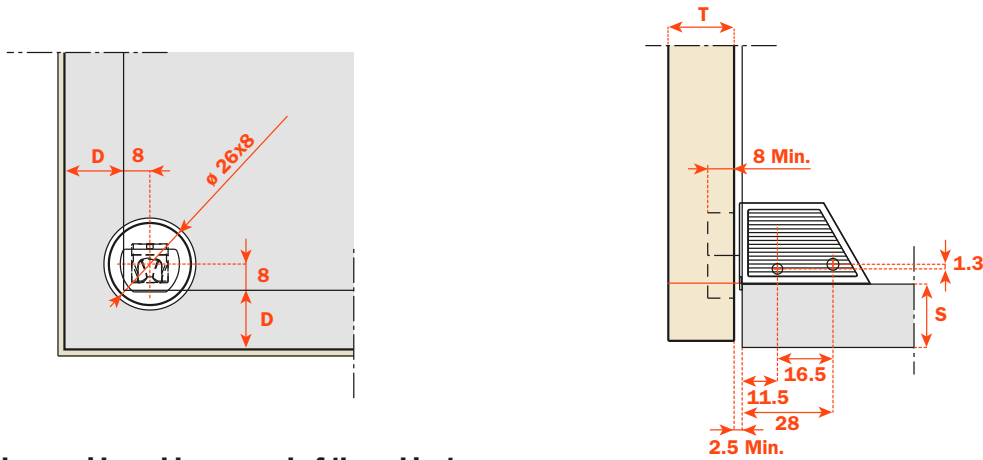

D = Door overlay on side and base panel of the cabinet
 Drilling distance of retaining catch = $D + 8$

Magnetic Push with magnetic retaining catch

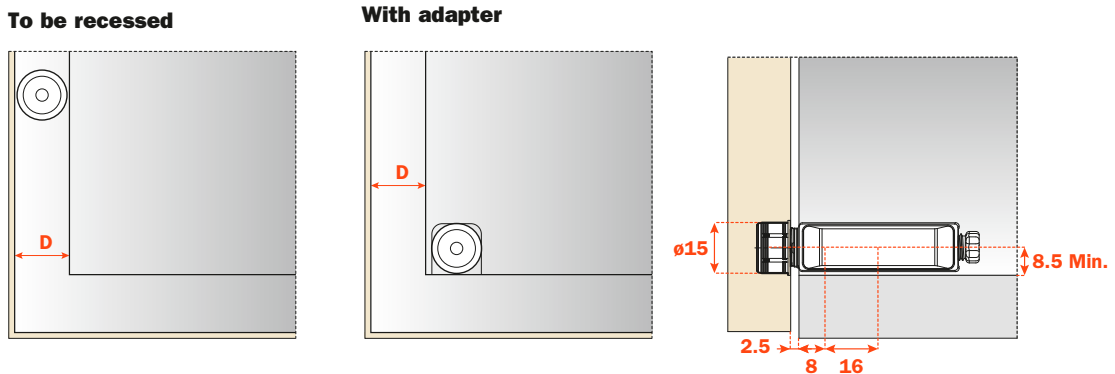

Drilling pattern for wooden door

Available fixing systems for the hinge cup:

- A** = wood screw fixing, 48x6 mm drilling
- P** = wood screw fixing, 45x9.5 mm drilling
- U** = wood screw fixing, 52x5.5 mm drilling
- B** = dowel fixing, 48x6 mm drilling
- R** = dowel fixing, 45x9.5 mm drilling
- W** = dowel fixing, 52x5.5 mm drilling
- 6** = Rapido fixing, 48x6 mm drilling
- 7** = Rapido fixing, 45x9.5 mm drilling
- 2** = Rapido fixing, 52x5.5 mm drilling

D = sideways and upper overlay

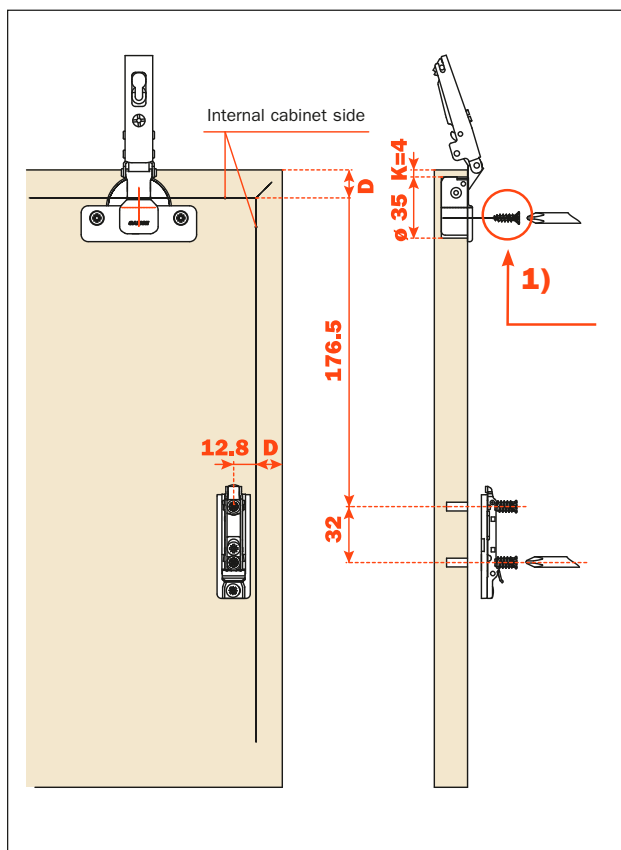

Drilling pattern for alu-framed door - width min. 17 mm, max. 24 mm

For alu-framed door, fix the mounting plate to the appropriate adapter.

D = sideways and upper overlay

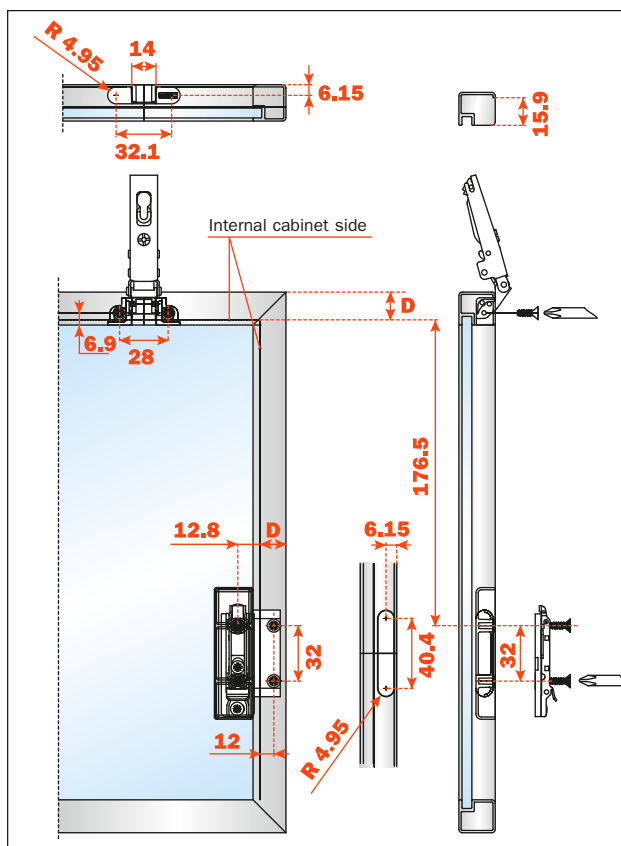

Drilling pattern for alu-framed door - width min. 45 mm

Available fixing system for the hinge cup:

- A** = wood screw fixing, 48x6 mm drilling
 - P** = wood screw fixing, 45x9.5 mm drilling
 - U** = woodscrew fixing, 52x5.5 mm drilling
- D** = sideways and upper overlay

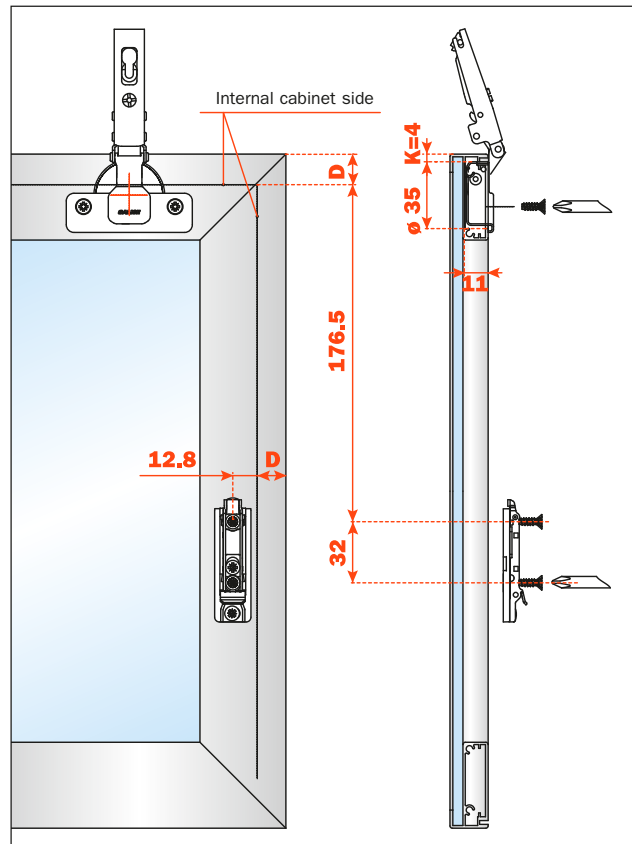

Fixing the support to the cabinet side

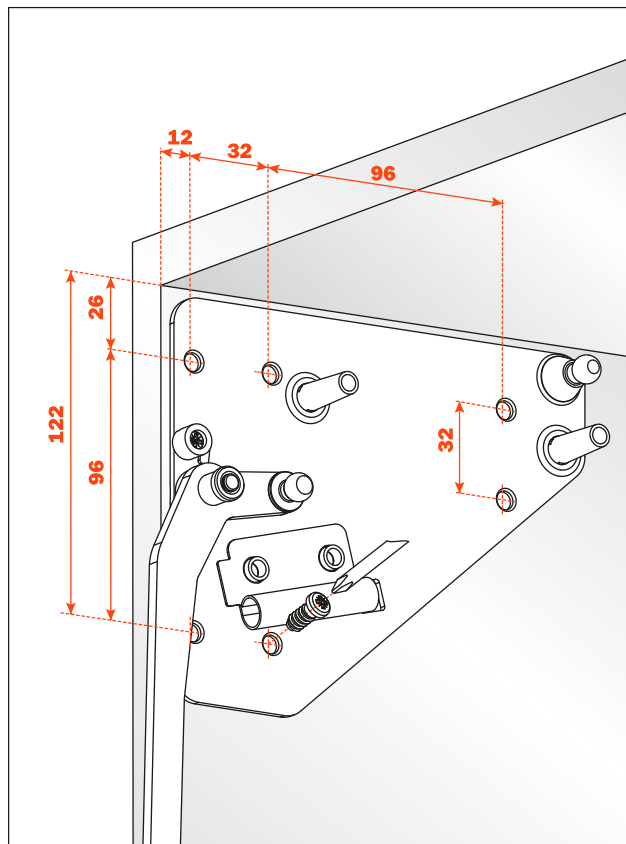

Deploying the piston

Carefully press each end of the piston securely onto the pins on the bracket and lifting arm, ensuring that the body of the piston is uppermost.

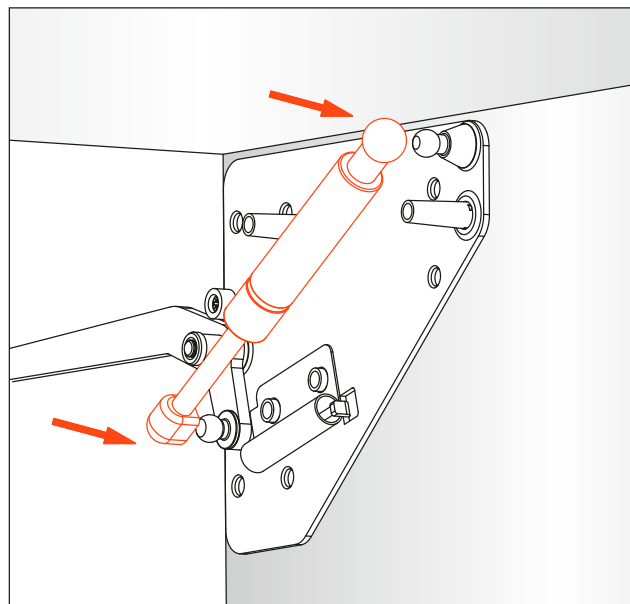

Fitting the door to the cabinet

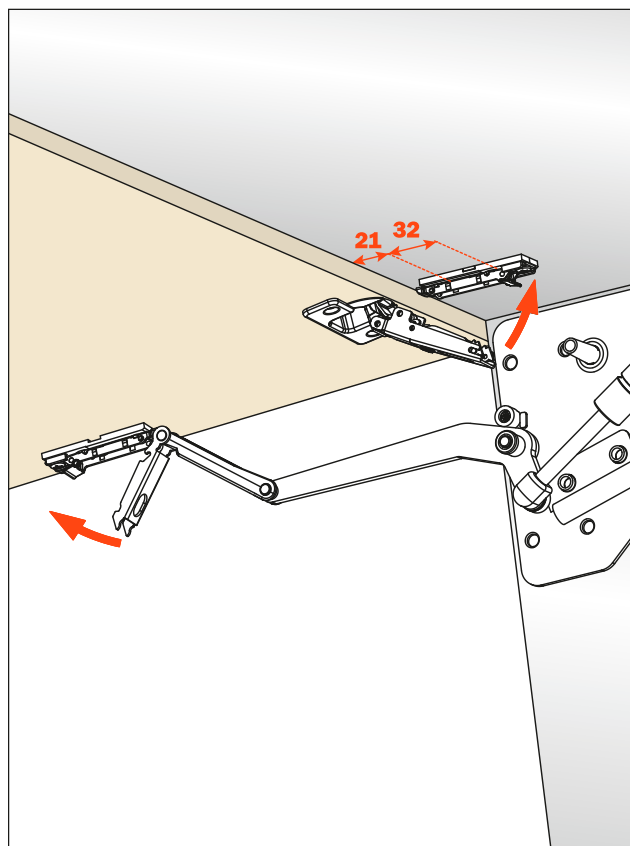

Installing the Smove

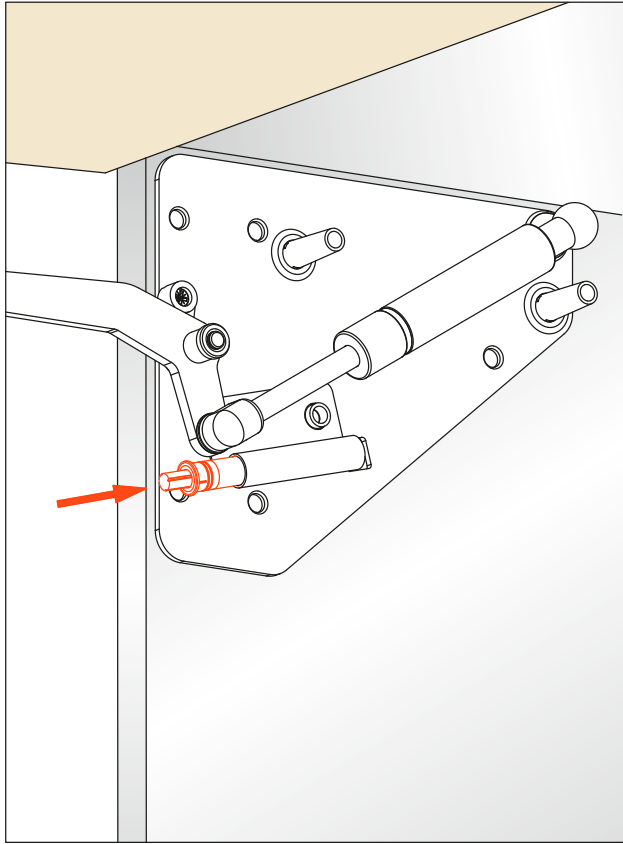

Adjustment of the opening angle of the door by cam

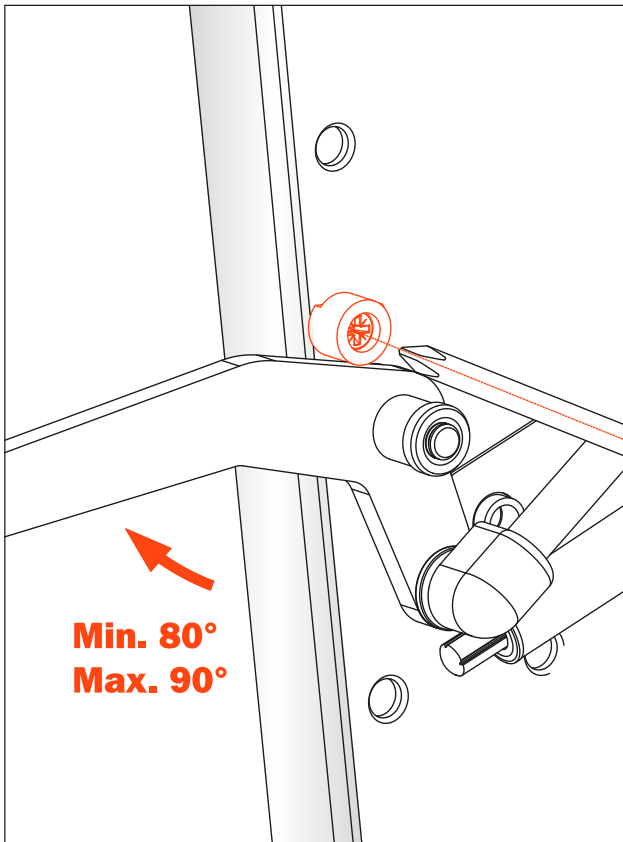

Installing the cover

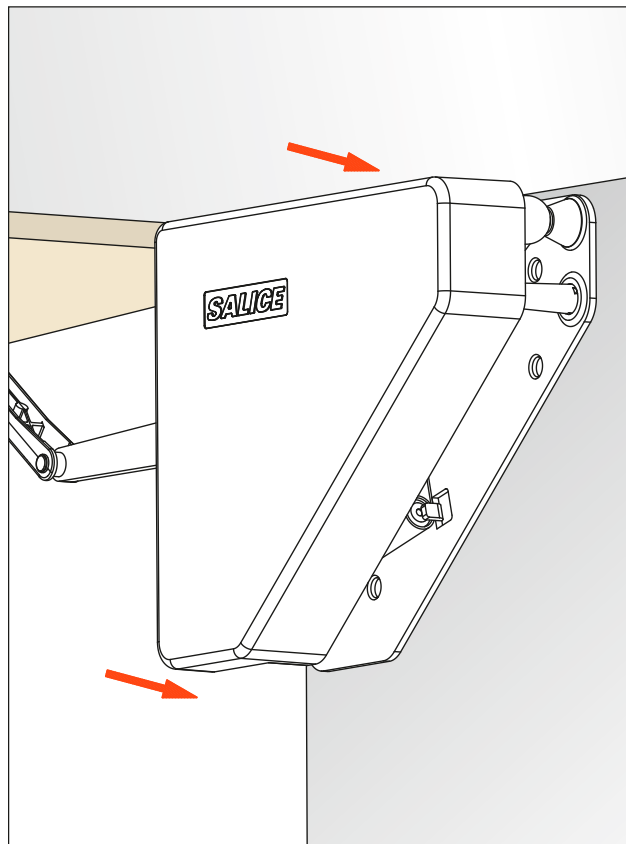

Disassembly

- A) Press the clip of the mounting plate
- B) then press firmly at this point

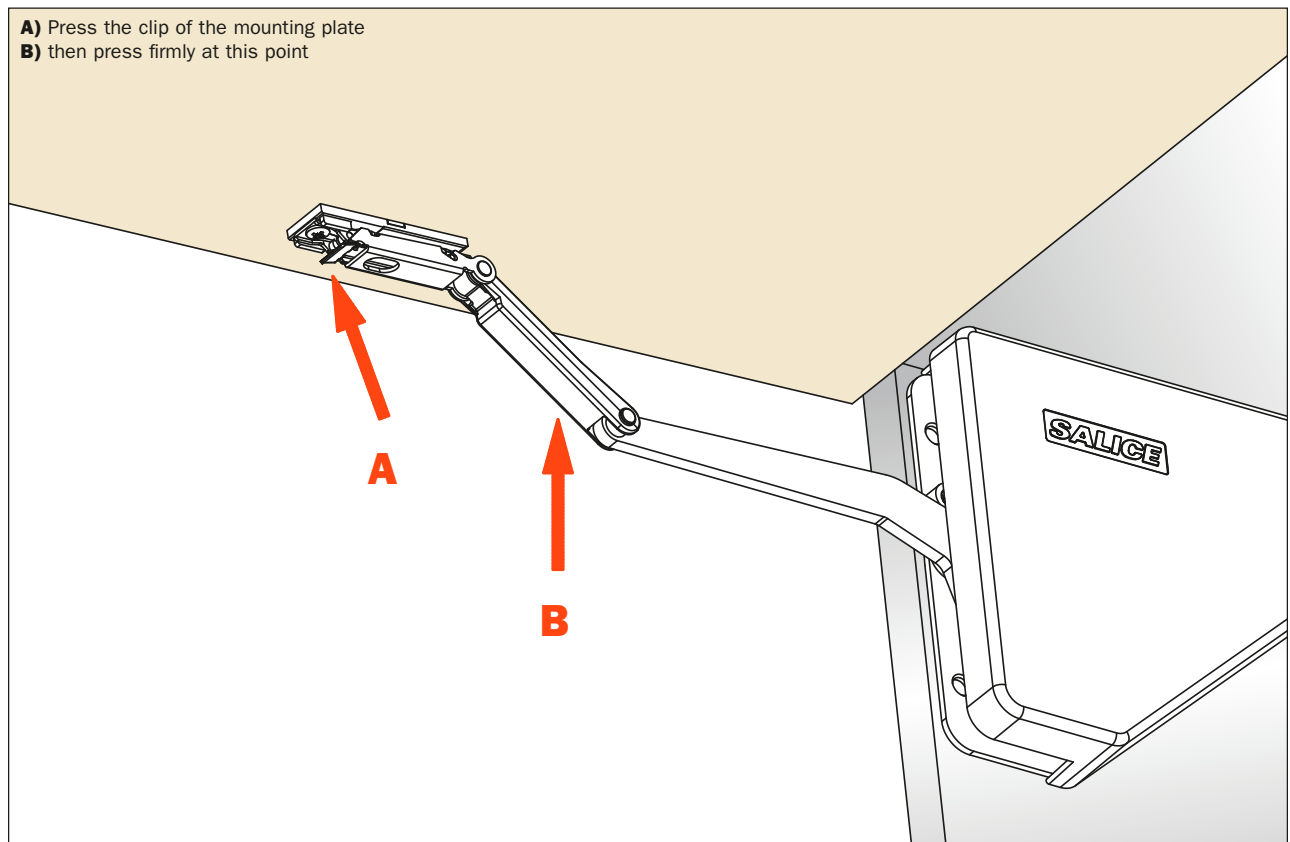

Dimensions of the system

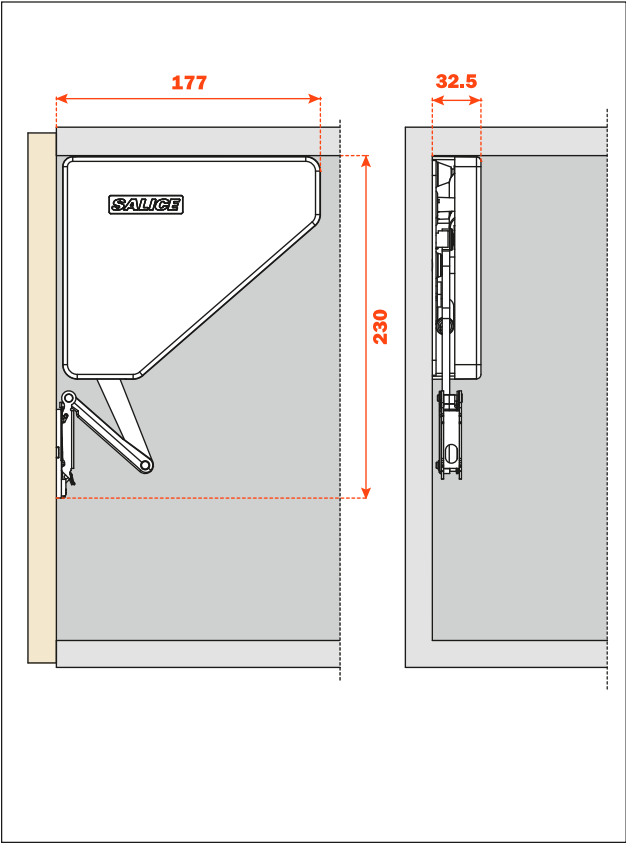

Lift - Opening systems - Flap door - Gas piston strength

Chart for FLMGSExxx pistons with single-operation door opening (systems with one piston)

Chart to define the exact strength (N) of the pistons to be used in relationship with the dimensions and weight of the doors.
 It is suggested that some assembly trials are made.
 Our technical Assistance Service is at your disposal for any additional information.

Cabinet width 600, 900 and 1200 mm

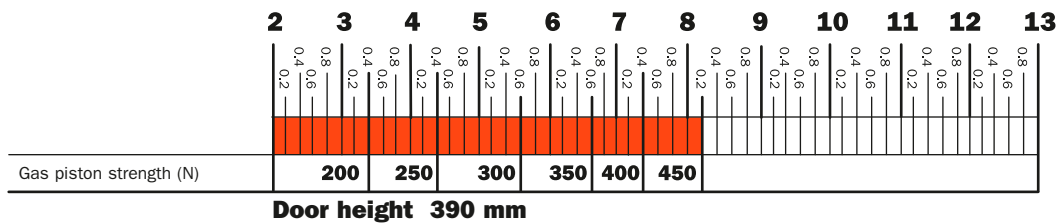
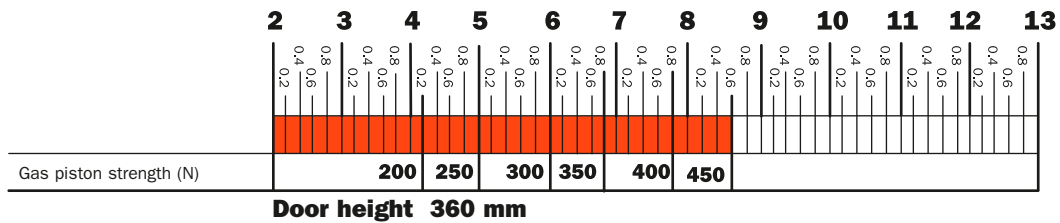
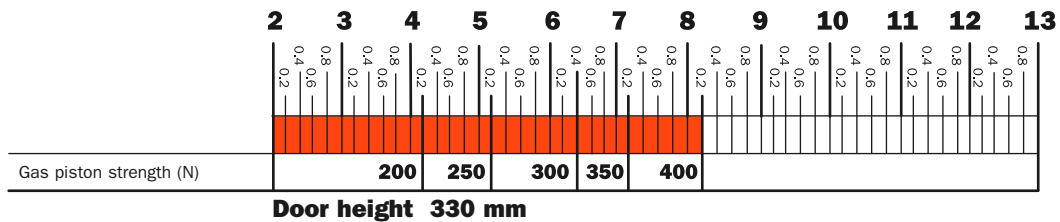
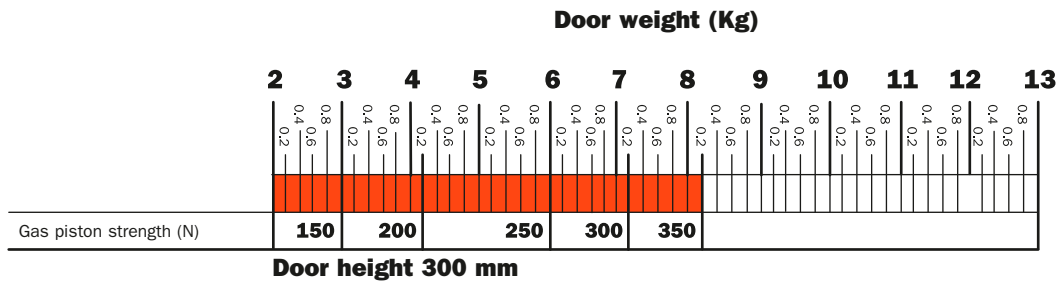
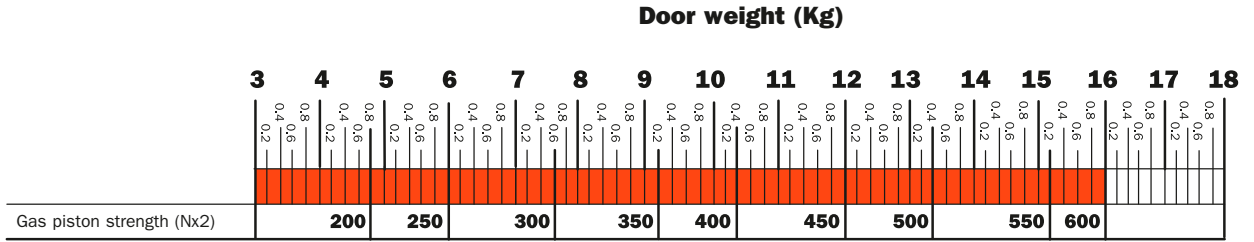

Chart for FLMGSExxx pistons with single-operation door opening (systems with two pistons)

Chart to define the exact strength (N) of the pistons to be used in relationship with the dimensions and weight of the doors.
 It is suggested that some assembly trials are made.
 Our technical Assistance Service is at your disposal for any additional information.

Cabinet width 600, 900 and 1200 mm



Door height 540 mm

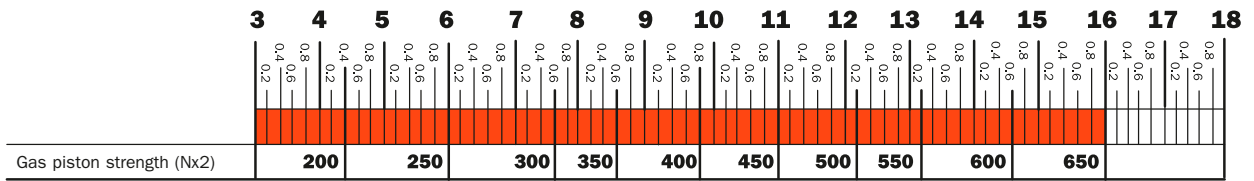

Door height 600 mm

Lift - Opening systems - Flap door - Gas piston strength

Chart for FLMGRExxx piston with progressive-operation door opening (systems with one piston)

Chart to define the exact strength (N) of the pistons to be used in relationship with the dimensions and weight of the doors. It is suggested that some assembly trials are made. Our technical Assistance Service is at your disposal for any additional information.

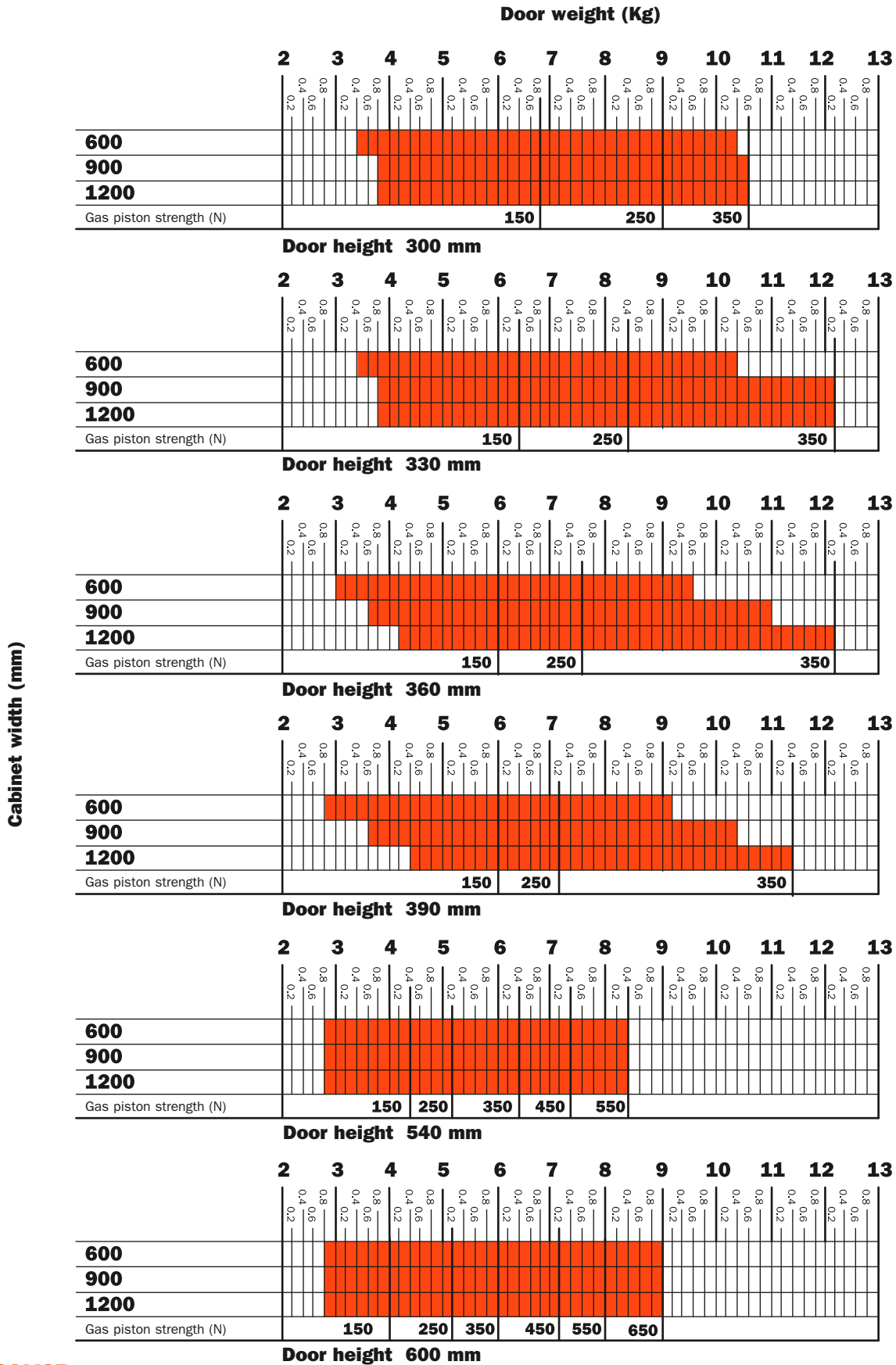
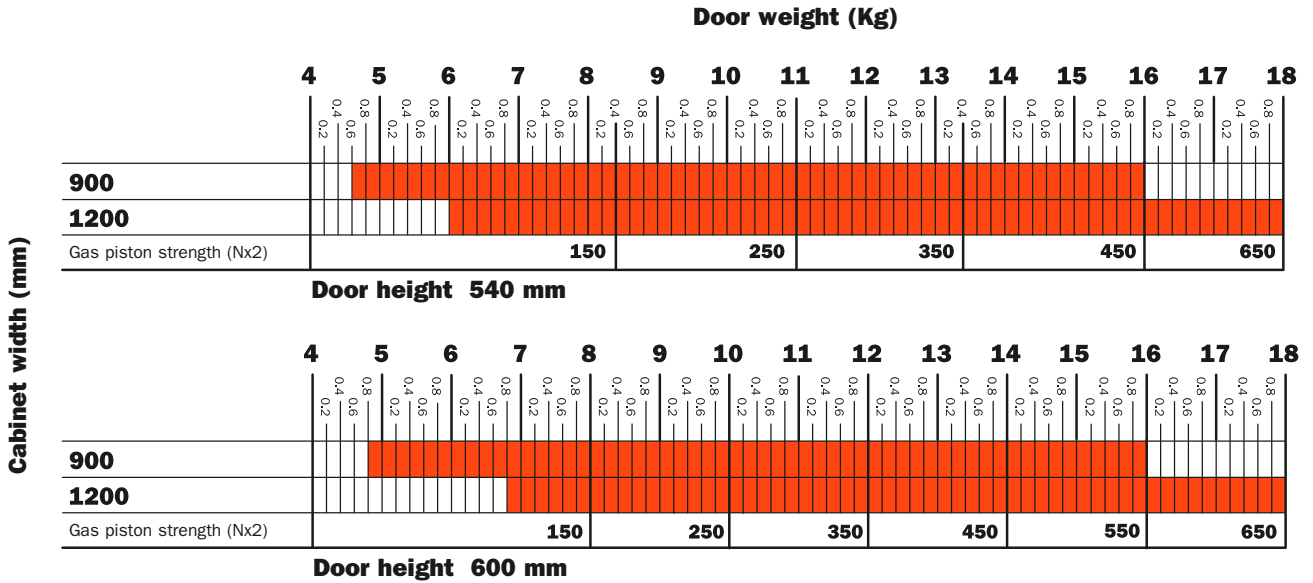

Chart for FLMGRExxx piston with progressive-operation door opening (system with two pistons)

Chart to define the exact strength (N) of the pistons to be used in relationship with the dimensions and weight of the doors.
 It is suggested that some assembly trials are made.
 Our technical Assistance Service is at your disposal for any additional information.



Lift - Opening systems - Folding door



Lift - Opening systems
Folding door



Part number composition

- F** = Lifting system
- L1** = Folding door opening
- D/S** = Right or left versions
- LL** = Cabinet height
- XX** = Special options
- SN** = Cover with Salice logo / **99** = Cover with arrangement for screw cover cap
- X** = Colour of the cover
- X1** = Cover with silk-screen printed logo

FL1XLLXXSNX

D = right version
S = left version

Cabinet height:
60 = 600 mm
66 = 660 mm
72 = 720 mm
78 = 780 mm
91 = 914 mm

G = grey cover
1 = white cover
9 = nickel-pl. cover



FL1XLLXX999

Part number for Lift system supplied with nickel-plated cover with arrangement for screw cover cap.

Screw cover cap to be ordered separately.



FL1XLLXX_9X1

Part number for Lift system supplied with nickel-plated cover with silk-screen printed logo.



Components of the system



FL1DLLXSNX

Lifting system - **right** side

Cover

Colour of the cover:

G = grey
1 = white
9 = nickel-pl.

Packing

Boxes 12 pcs.

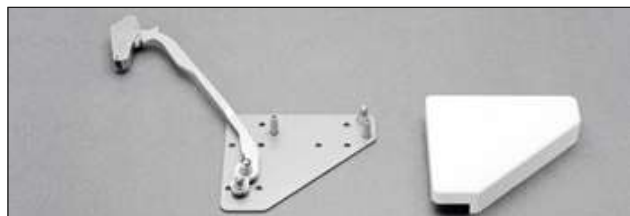

FL1SLLXSNX

Lifting system - **left** side

Cover

Colour of the cover:

G = grey
1 = white
9 = nickel-pl.

Packing

Boxes 12 pcs.

To be ordered separately:

C2_6A99



Hinge for door.
See page 304 and 305 to complete the part number with the available fixing systems.

Packing

Boxes 300 pcs.

BAPGR39



Mounting plate for the top of the wall cabinet.
Mounting plate for door.

Packing

Boxes 300 pcs.

FLMGSE **XXX** ← Fill with the required piston strength



Gas piston.
See page 310 to complete the part number with the appropriate piston strength.

Packing

Boxes 12 pcs.

D00SSNG



Smove

For doors of small weight and dimensions.

Packing

Boxes 250 pcs.

FLMGRE **XXX** ← Fill with the required piston strength



Progressive gas piston.
See page 311 to complete the part number with the appropriate piston strength.

Packing

Boxes 12 pcs.

D00FSNG



Smove

For doors of middle weight and dimensions.

Packing

Boxes 250 pcs.

FLC_E9R



Central hinge with height and sideways adjustment ± 1.5 mm.
See page 304 and 305 to complete the part number with the available fixing systems.

Packing

Boxes 150 pcs.

D00LSNG



Smove

For doors of large weight and dimensions.

Packing

Boxes 250 pcs.

Drilling pattern for the upper wooden door

Available fixing systems for the hinge cup:

- A** = wood screw fixing, 48x6 mm drilling
- P** = wood screw fixing, 45x9.5 mm drilling
- U** = wood screw fixing, 52x5.5 mm drilling
- B** = dowel fixing, 48x6 mm drilling
- R** = dowel fixing, 45x9.5 mm drilling
- W** = dowel fixing, 52x5.5 mm drilling
- 6** = Rapido fixing, 48x6 mm drilling
- 7** = Rapido fixing, 45x9.5 mm drilling
- 2** = Rapido fixing, 52x5.5 mm drilling

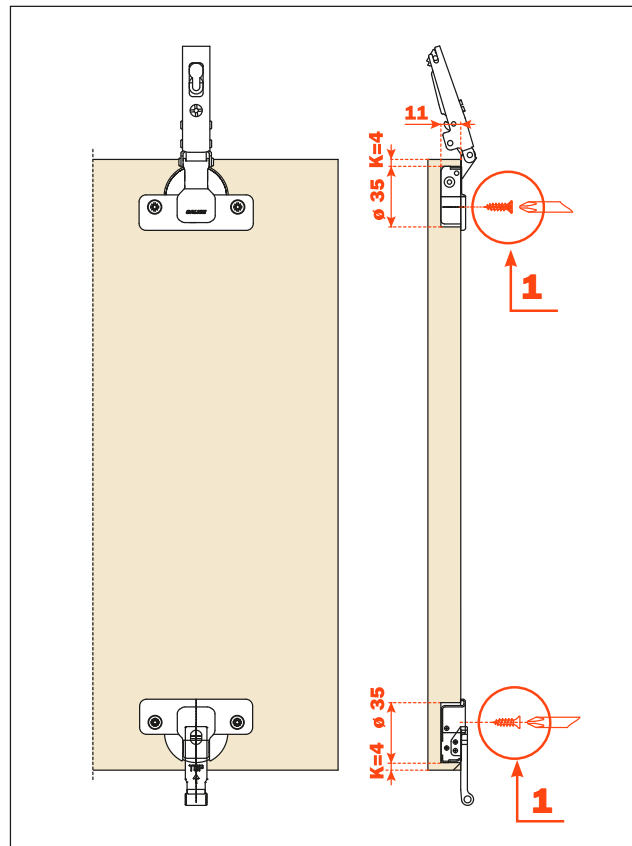
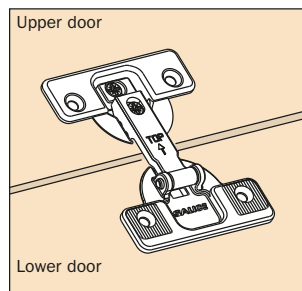

Drilling pattern for the lower wooden door

Available fixing systems for the hinge cup:

- A** = wood screw fixing, 48x6 mm drilling
- P** = wood screw fixing, 45x9.5 mm drilling
- U** = wood screw fixing, 52x5.5 mm drilling
- B** = dowel fixing, 48x6 mm drilling
- R** = dowel fixing, 45x9.5 mm drilling
- W** = dowel fixing, 52x5.5 mm drilling
- 6** = Rapido fixing, 48x6 mm drilling
- 7** = Rapido fixing, 45x9.5 mm drilling
- 2** = Rapido fixing, 52x5.5 mm drilling

D = sideways overlay

* Dimension is valid for cabinet heights 600, 660, 720 and 780 mm.
For cabinets of different heights, please consult Salice customer service for the correct value.

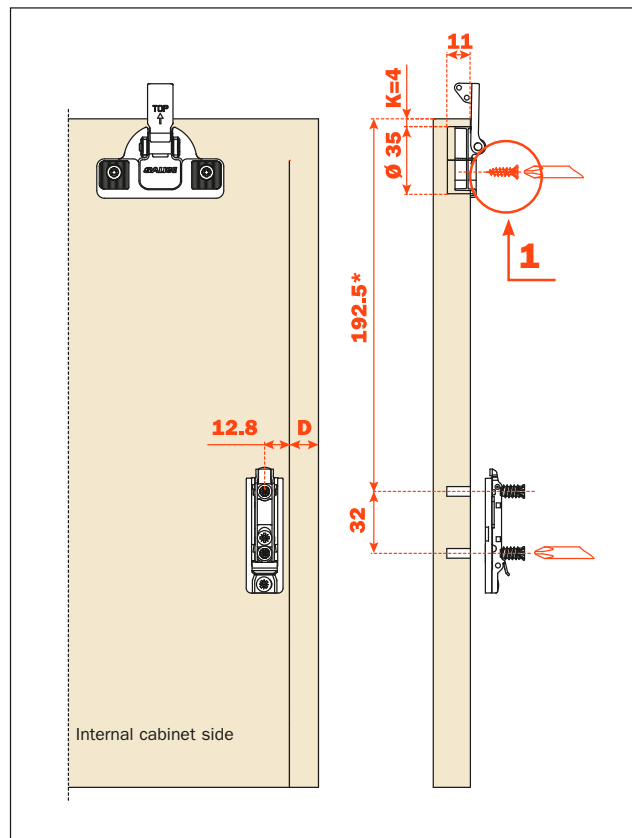
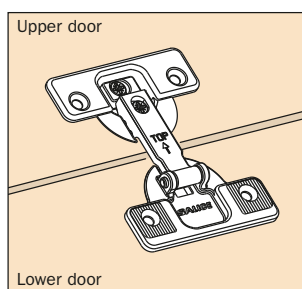

Drilling pattern for the upper alu-framed door - width min. 45 mm

Available fixing systems for the hinge cup:

- A** = woodscrew fixing, 48x6 mm drilling
- P** = woodscrew fixing, 45x9.5 mm drilling
- U** = woodscrew fixing, 52x5.5 mm drilling

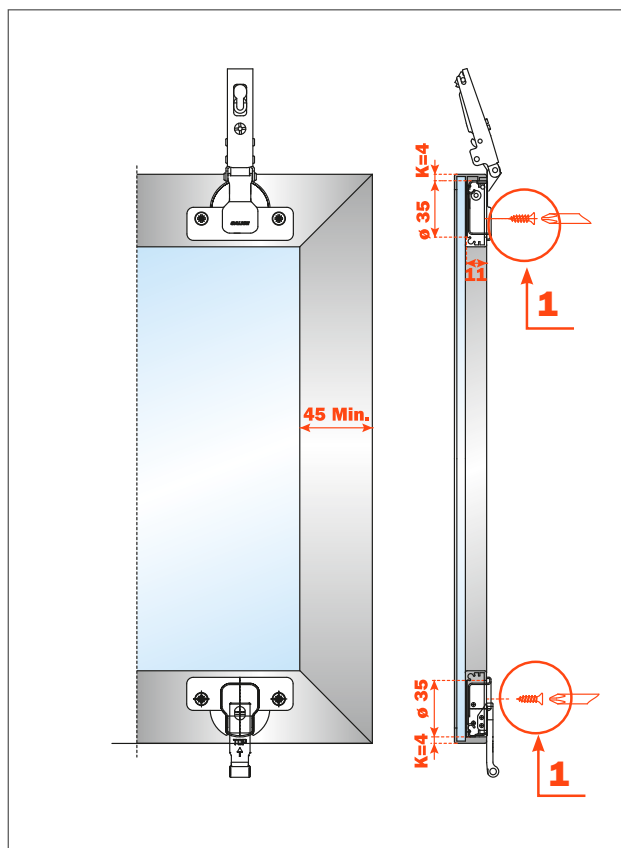
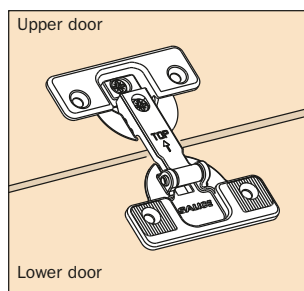

Drilling pattern for the lower alu-framed door - width min. 45 mm

Available fixing systems for the hinge cup:

- A** = wood screw fixing, 48x6 mm drilling
- P** = wood screw fixing, 45x9.5 mm drilling
- U** = wood screw fixing, 52x5.5 mm drilling

D = sideways overlay

* Dimension is valid for cabinet heights 600, 660, 720 and 780 mm.
For cabinets of different heights, please consult Salice customer service for the correct value.

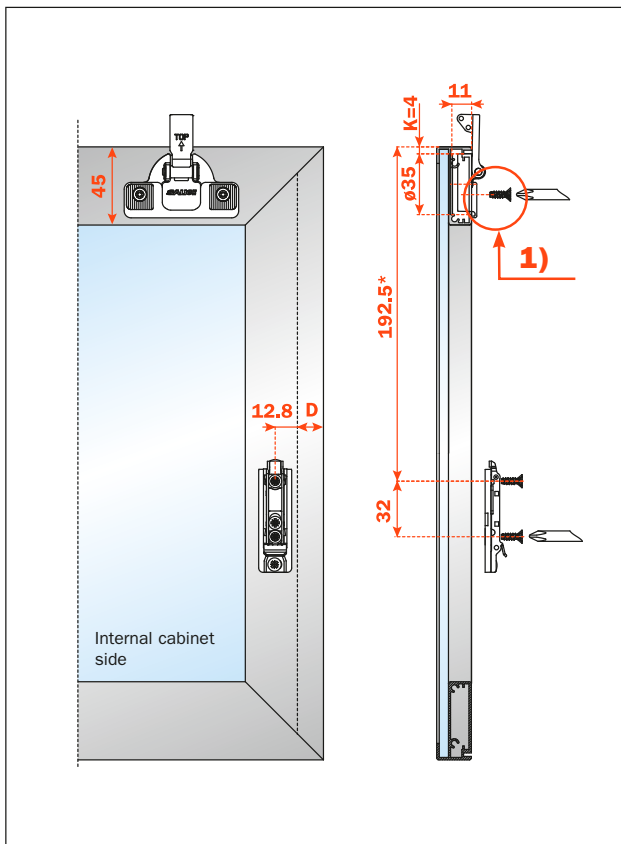
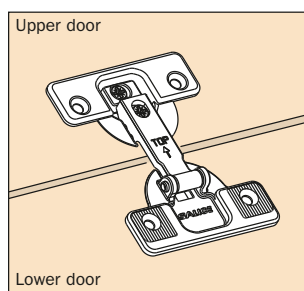

Fixing the support to the cabinet side

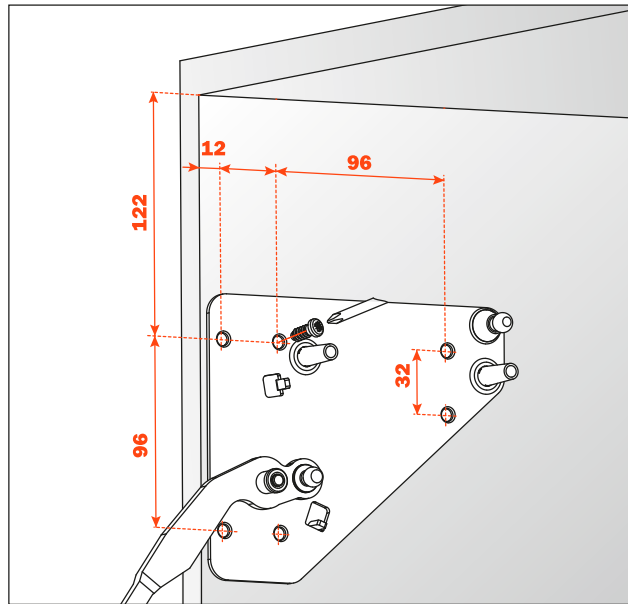

Deploying the piston

Carefully press each end of the piston securely onto the pins on the bracket and lifting arm, ensuring that the body of the piston is uppermost.

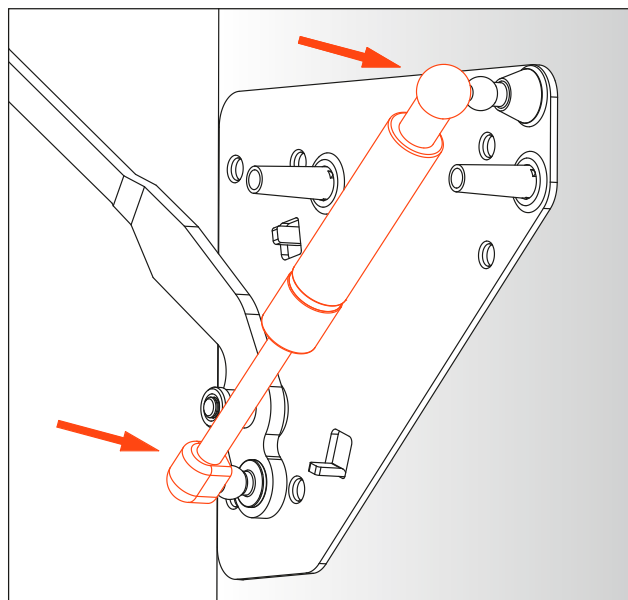

Installing the Smove

We suggest:

DOOFSNG for doors up to 6 kg

DOOLSNNG for doors over 6 kg

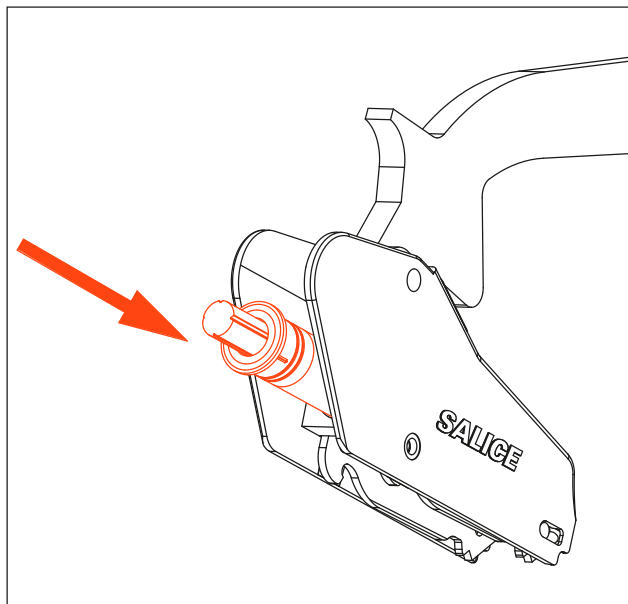

Fitting the doors to the cabinet

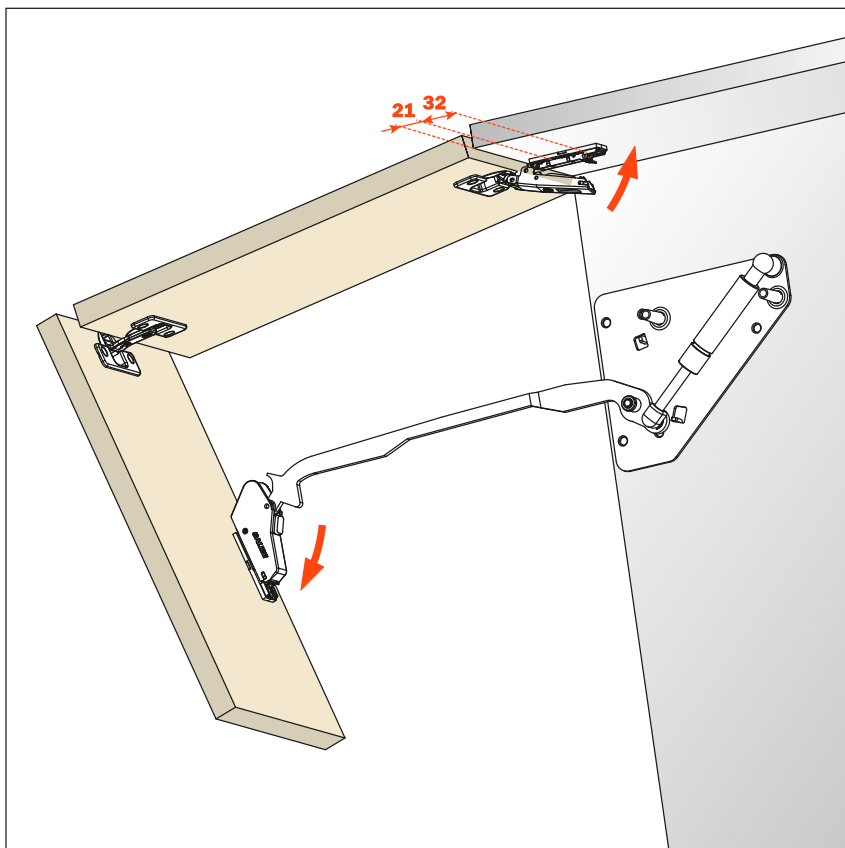

Installing the cover

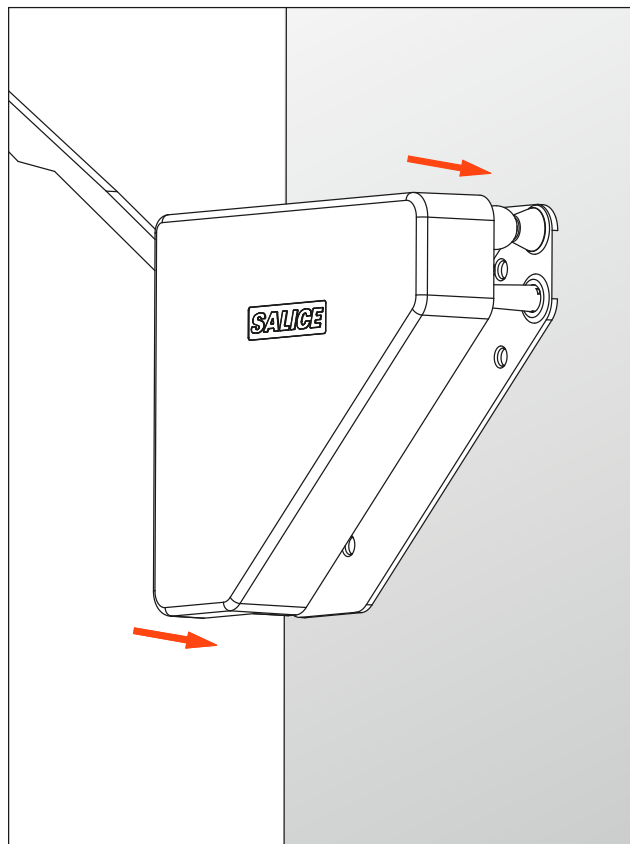

Dimensions of the system

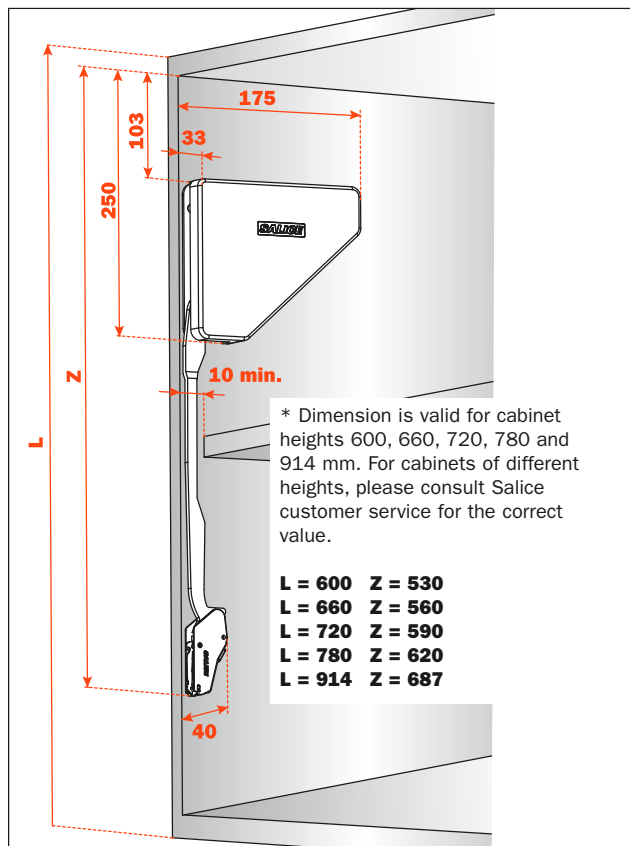

The shape of the lifting arm allows the use of shelves with a reduced depth of 10 mm only compared with the cabinet depth.

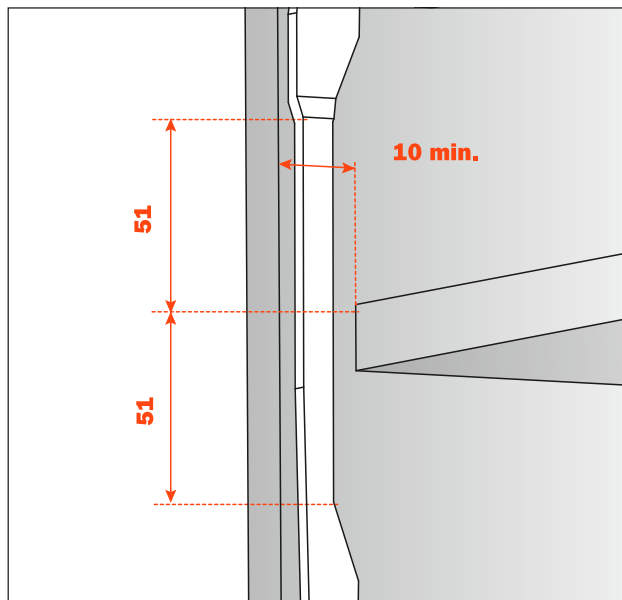

Replacement of the gas piston

Disconnect the lever arm from the lower door

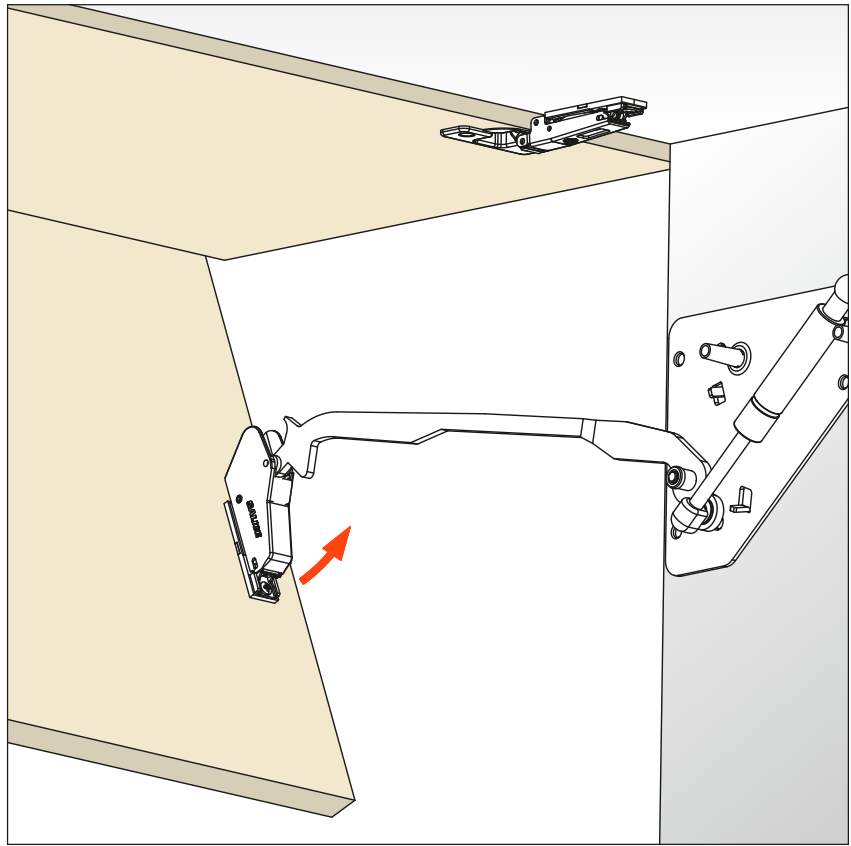

Disconnect the gas piston when it is fully extended

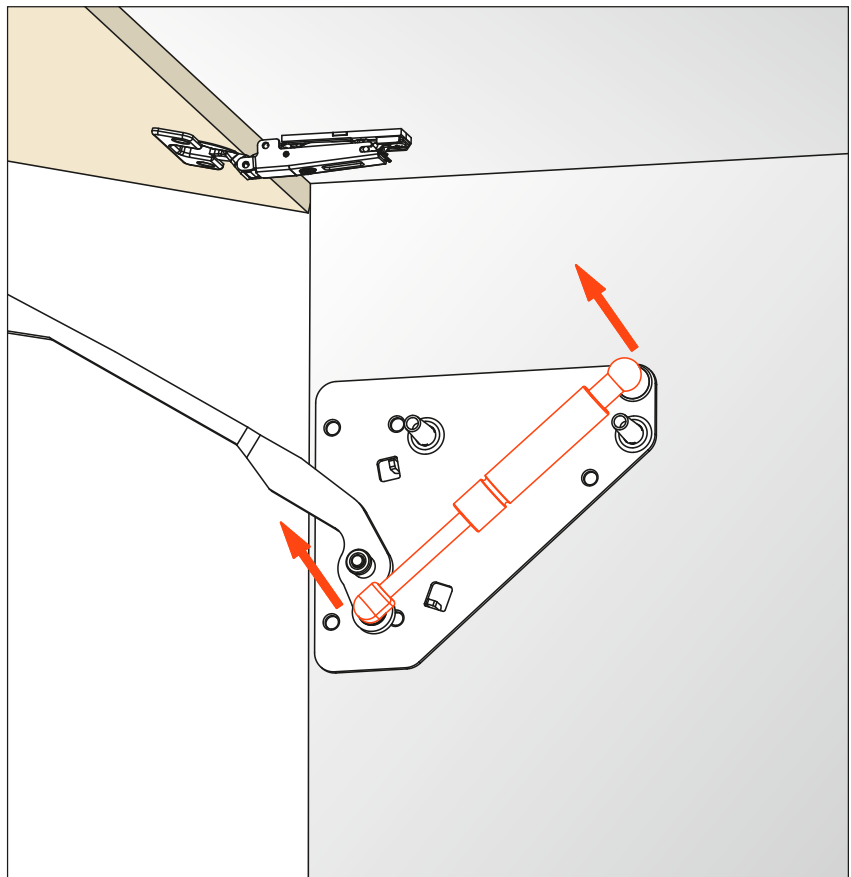

Chart for FLMGSExxx pistons with single-operation door opening

Chart to define the exact strength of the pistons to be used in relationship with the dimensions and weight of the doors.
It is suggested that some assembly trials are made. Our technical assistance service is at your disposal for any additional information.
For wall cabinet width 600 mm, it is possible to use one system only, right or left version.

Cabinet width 600, 900 and 1200 mm

Weight of the two doors (Kg)

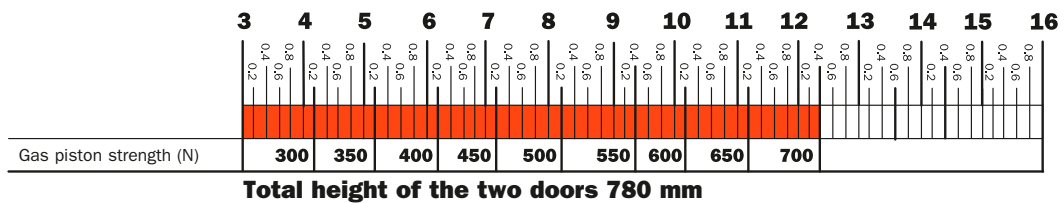
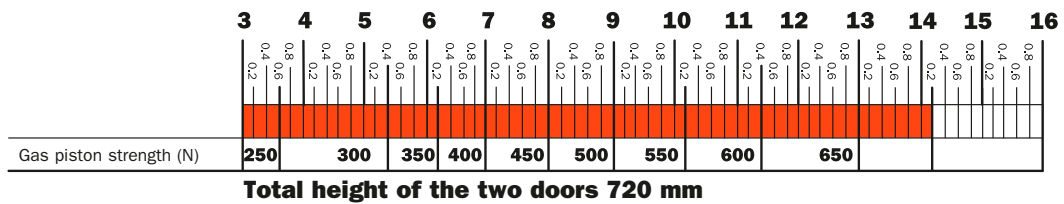
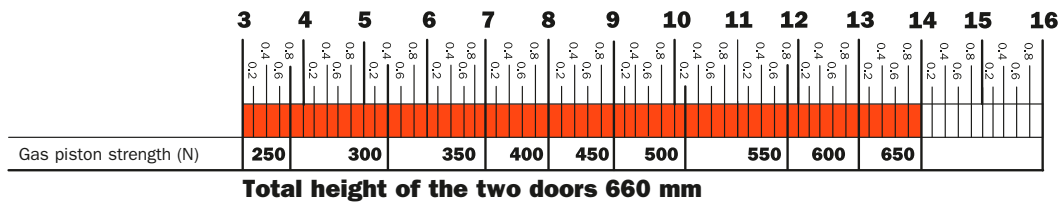
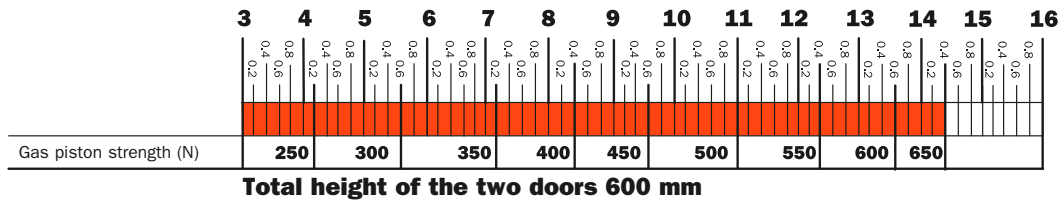
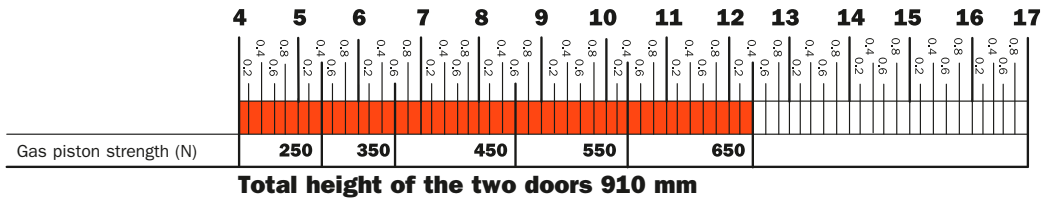
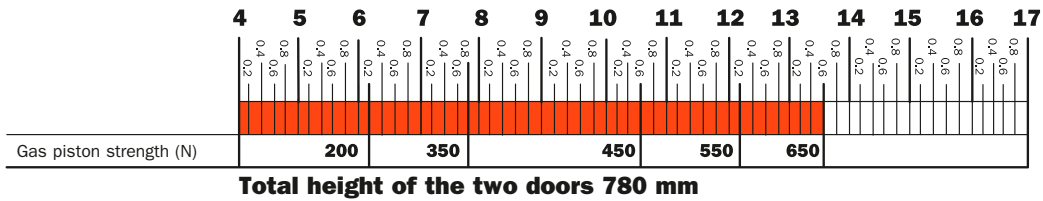
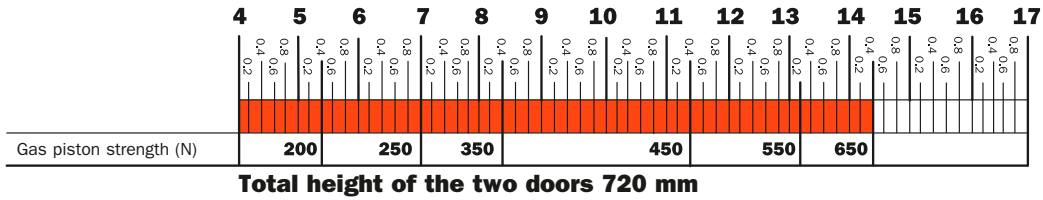
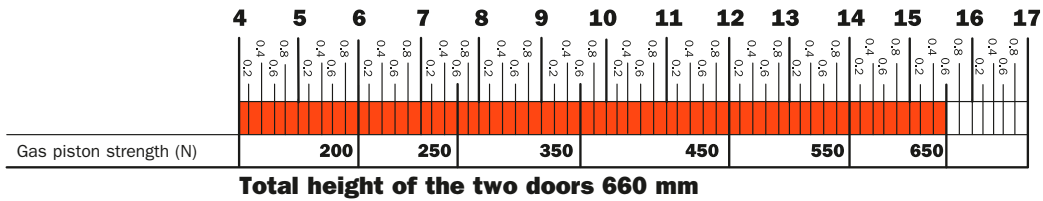
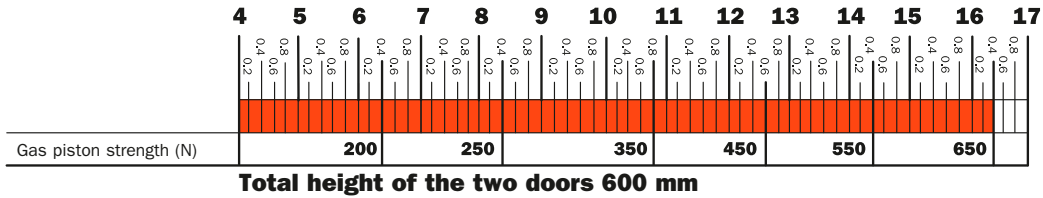

Chart for FLMGRExxx pistons with progressive-operation door opening

Chart to define the exact strength of the pistons to be used in relationship with the dimensions and weight of the doors.
It is suggested that some assembly trials are made. Our technical assistance service is at your disposal for any additional information.
For wall cabinet width 600 mm, it is possible to use one system only, right or left version.

Cabinet width 600, 900 and 1200 mm

Weight of the two doors (Kg)



Lift - Opening systems - Parallel opening door

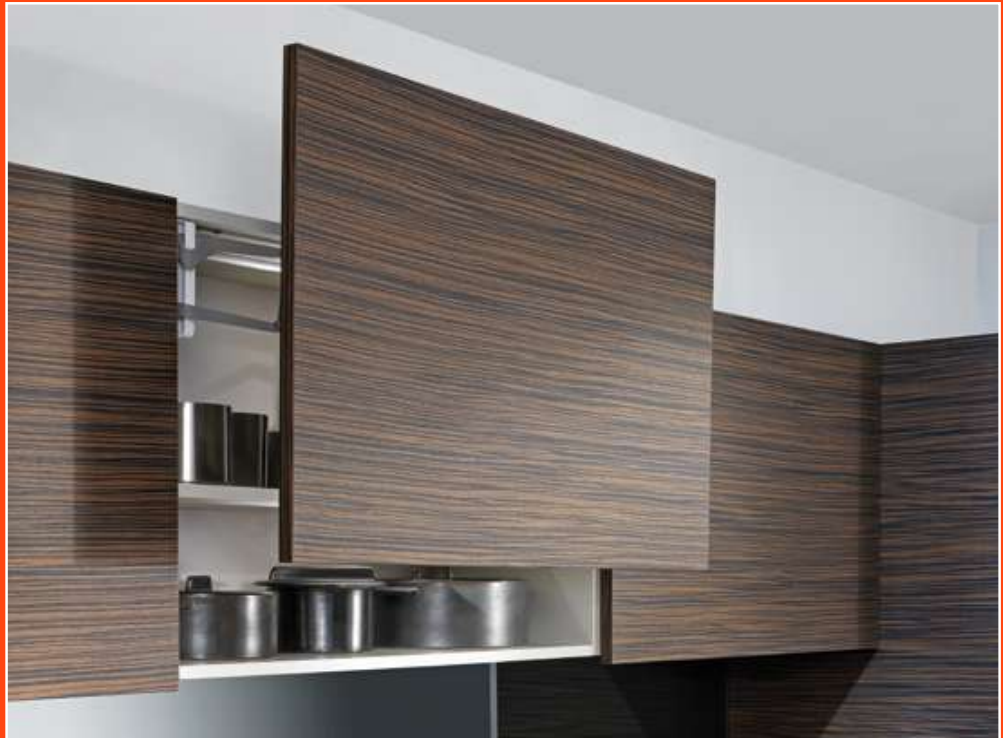

Lift - Opening systems - Parallel opening door
For doors from 360 mm to 440 mm height





Part number composition

- F** = Lifting system
- P** = Parallel opening door
- XXXXXX** = Special options
- SN** = Cover with Salice logo / **99** = Cover with arrangement for screw cover cap
- X** = Colour of the cover
- X1** = Cover with silk-screen printed log

FPXXXXXSX

↑

G = grey cover
1 = white cover
9 = nickel-pl. cover



FPXXXXX999

Part number for Lift system supplied with nickel-plated cover with arrangement for screw cover cap.

Screw cover cap to be ordered separately.



FPXXXXX_9X1

Part number for Lift system supplied with nickel-plated cover with silk-screen printed logo.

Lift - Opening systems - Parallel opening door

For doors from 360 mm to 440 mm height



Components of the system for wooden door



FPXXXXXXSNX

Lifting system - **right** side

Lifting system - **left** side

Cover

Colour of the cover:

- G = grey
- 1 = white
- 9 = nickel-pl.

Packing

Boxes 6 pairs

To be ordered separately:

BAPGR39

Mounting plate for door



Packing

Boxes 300 pcs.

D00SSNG

For doors of small weight and dimensions.



Packing

Boxes 250 pcs.

FLMGSE XXX ← Fill with the required piston strength

Gas piston.
See page 329 to complete the part number with the appropriate piston strength.



Packing

Boxes 12 pcs.

D00FSNG

Smove

For doors of middle weight and dimensions.



Packing

Boxes 250 pcs.

FLMGRE XXX ← Fill with the required piston strength

Gas piston.
See page 329 to complete the part number with the appropriate piston strength.



Packing

Boxes 12 pcs.

D00LSNG

Smove

For doors of large weight and dimensions.



Packing

Boxes 250 pcs.

Stabilizer bar



- FPXX59KX445 for door width 600 mm
- FPXX59KX745 for door width 900 mm
- FPXX59K1045 for door width 1200 mm

Packing

Boxes 6 pcs.



Components of the system for alu-framed door



FPXXXXXXSNX

Lifting system - **right** side

Lifting system - **left** side

Cover

Colour of the cover:

G = grey
1 = white
9 = nickel-pl.

Packing

Boxes 6 pairs

To be ordered separately:

BAP3R39

Mounting plate for door



Packing

Boxes 300 pcs.

D00SSNG

Smove
For doors of small weight and dimensions.



Packing

Boxes 250 pcs.

FLMGSE XXX ← Fill with the required piston strength

Gas piston.
See page 329 to complete the part number with the appropriate piston strength.



Packing

Boxes 12 pcs.

D00FSNG

Smove
For doors of middle weight and dimensions.



Packing

Boxes 250 pcs.

FLMGRE XXX ← Fill with the required piston strength

Gas piston.
See page 329 to complete the part number with the appropriate piston strength.



Packing

Boxes 12 pcs.

D00LSNG

Smove
For doors of large weight and dimensions.



Packing

Boxes 250 pcs.

DBZXBH9

Support for plate with fixing screws.



Packing

Boxes 150 pcs.

Stabilizer bar



FPXX59KX445 for door width 600 mm
FPXX59KX745 for door width 900 mm
FPXX59K1045 for door width 1200 mm

Packing

Boxes 6 pcs.

Lift - Opening systems - Parallel opening door

For doors from 440 mm to 660 mm height



Part number composition

- F** = Lifting system
- P** = Parallel opening door
- XXXXXX** = Special options
- SN** = Cover with Salice logo / **99** = Cover with arrangement for screw cover cap
- X** = Colour of the cover
- L** = Long arm
- X1** = Cover with silk-screen printed logo

FPXXXXXSX**L**

↑

G = grey cover
1 = white cover
9 = nickel-pl. cover



FPXXXXX**99**L

Part number for LIFT system supplied with nickel-plated cover with arrangement for screw cover cap.



FPXXXXX_**9**L**X1**

Part number for LIFT system supplied with nickel-plated cover with silk-screen printed logo.



Components of the system for wooden door



FPXXXXXXSNXL

Lifting system - **right** side

Lifting system - **left** side

Cover.

Colour of the cover:

G = grey
1 = white
9 = nickel-pl.

Packing

Boxes 6 pairs

To be ordered separately:

BAPGR39

Mounting plate for door



Packing

Boxes 300 pcs.

D00SSNG

Smove

For doors of small weight and dimensions.



Packing

Boxes 250 pcs.

FLMGSE XXX ← Fill with the required piston strength

Gas piston.
See page 330 to complete the part number with the appropriate piston strength.



Packing

Boxes 12 pcs.

D00FSNG

Smove

For doors of middle weight and dimensions.



Packing

Boxes 250 pcs.

FLMGRE XXX ← Fill with the required piston strength

Progressive gas piston.
See page 331 to complete the part number with the appropriate piston strength.



Packing

Boxes 12 pcs.

D00LSNG

Smove

For doors of large weight and dimensions.



Packing

Boxes 250 pcs.

Stabilizer bar



FPXX59KX445 for door width 600 mm

FPXX59KX745 for door width 900 mm

FPXX59K1045 for door width 1200 mm

Packing

Boxes 6 pcs.

Lift - Opening systems - Parallel opening door

For doors from 440 mm to 660 mm height



Components of the system for alu-framed door



FPXXXXXXSNXL

Lifting system - **right** side

Lifting system - **left** side

Cover

Colour of the cover:

G = grey
1 = white
9 = nickel-pl.

Packing

Boxes 6 pairs

To be ordered separately:

BAP3R39

Mounting plate for door



Packing

Boxes 300 pcs.

D00SSNG

Smove

For doors of small weight and dimensions.



Packing

Boxes 250 pcs.

FLMGSE XXX ← Fill with the required piston strength

Gas piston.
See page 330 to complete the part number with the appropriate piston strength.



Packing

Boxes 12 pcs.

D00FSNG

Smove

For doors of middle weight and dimensions.



Packing

Boxes 250 pcs.

FLMGRE XXX ← Fill with the required piston strength

Progressive gas piston.
See page 331 to complete the part number with the appropriate piston strength.



Packing

Boxes 12 pcs.

D00LSNG

Smove

For doors of large weight and dimensions.



Packing

Boxes 250 pcs.

DBZXBH9

Support for plate with fixing screws.



Packing

Boxes 150 pcs.

Stabilizer bar



FPXX59KX445 for door width 600 mm
FPXX59KX745 for door width 900 mm
FPXX59K1045 for door width 1200 mm

Packing

Boxes 6 pcs.

Drilling pattern for wooden door and alu-framed door
For doors from 360 to 440 mm height

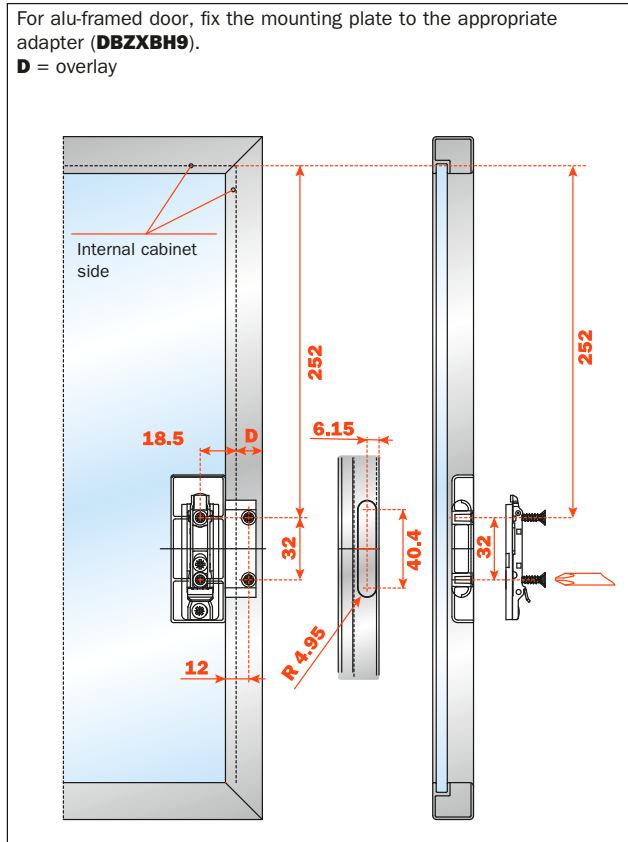
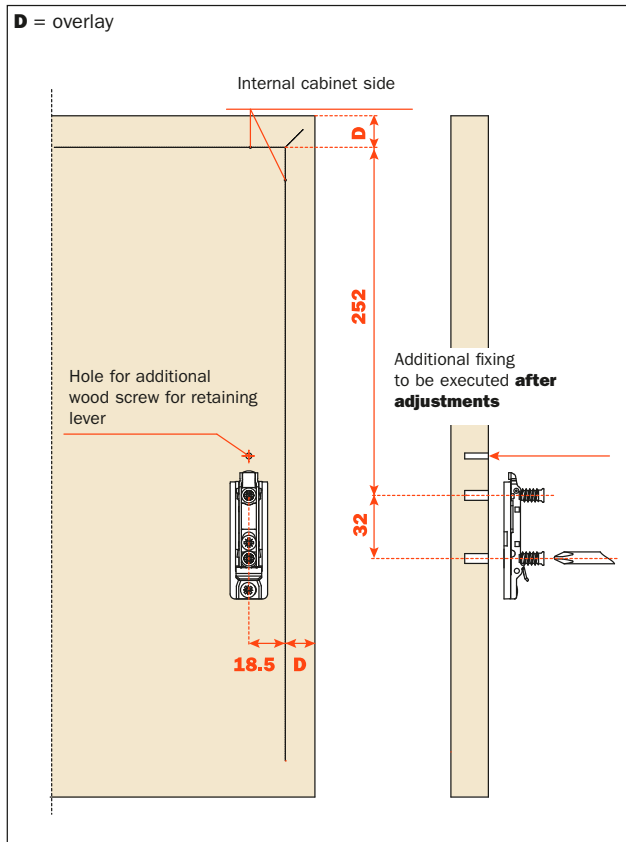

Drilling pattern for wooden door and alu-framed door
For doors from 440 to 660 mm height.

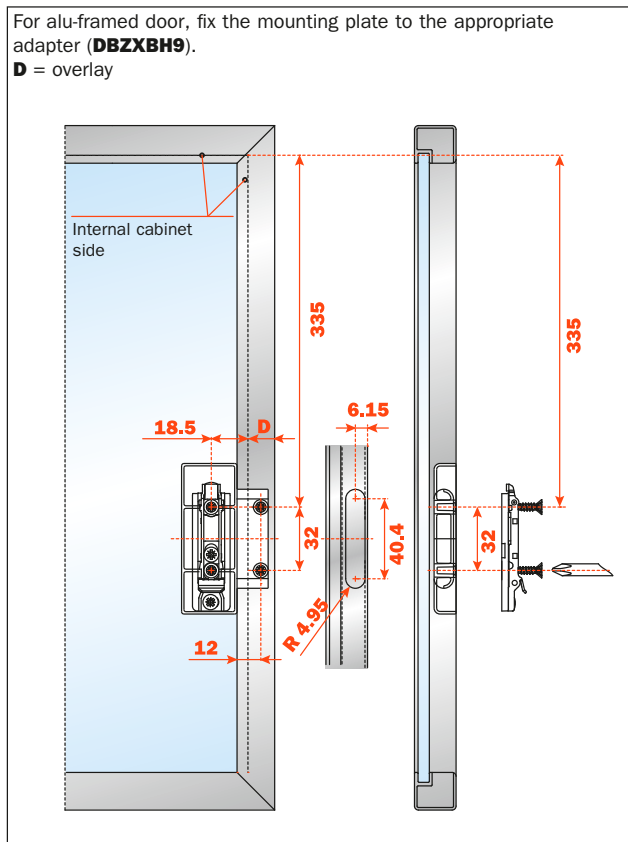
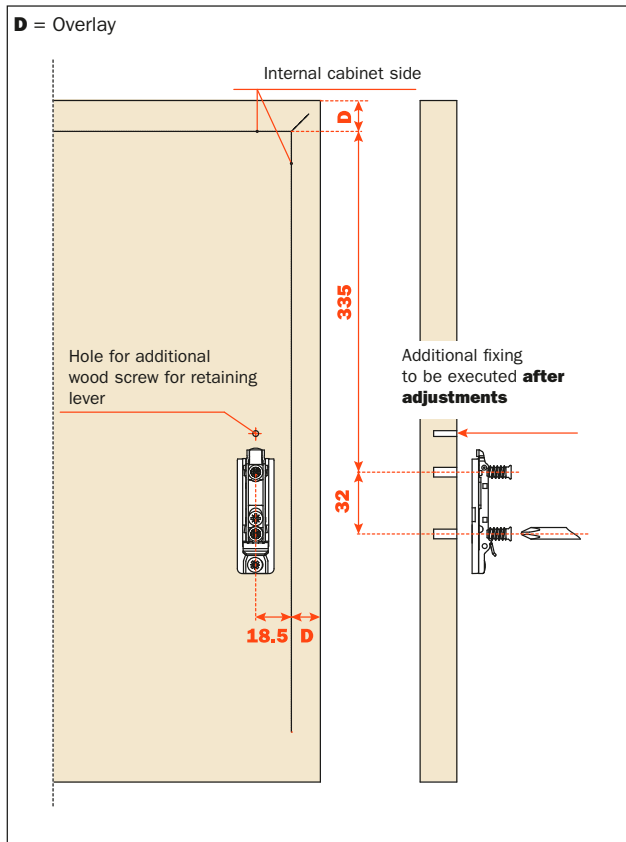

Fixing the support to the cabinet side

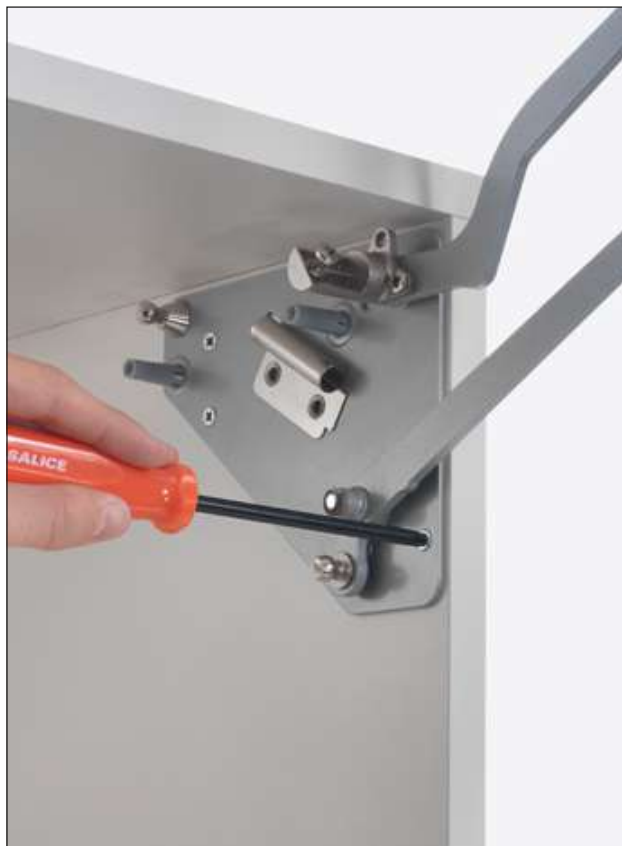
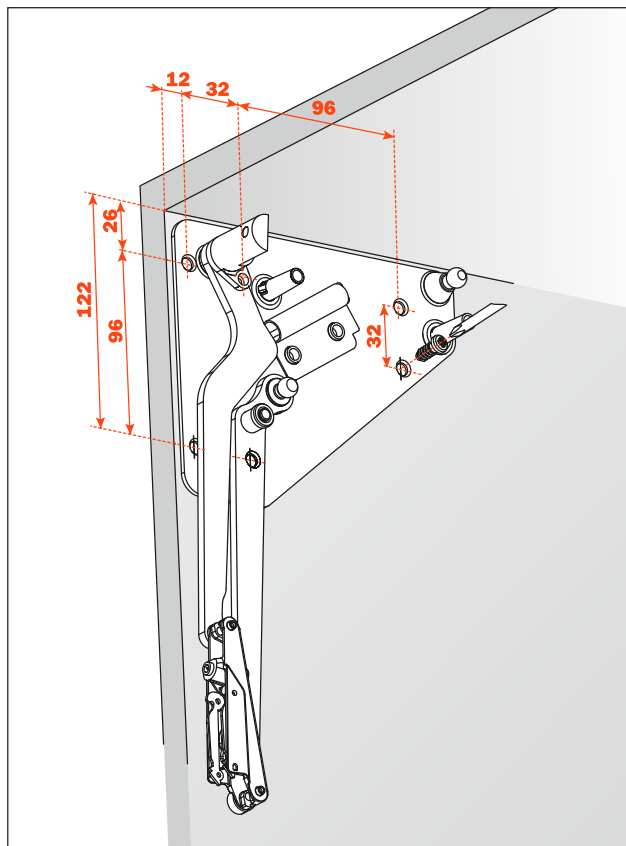

Deploying the piston

Carefully press each end of the piston securely onto the pins on the bracket and lifting arm, ensuring that the body of the piston is uppermost.

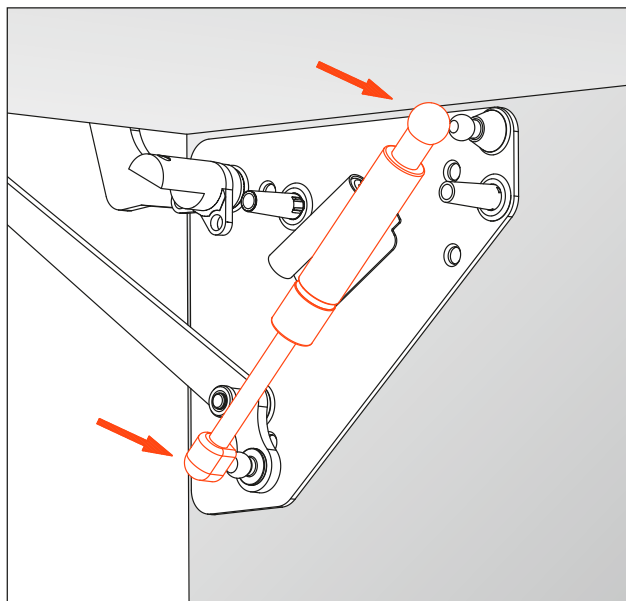

Installing the Smove

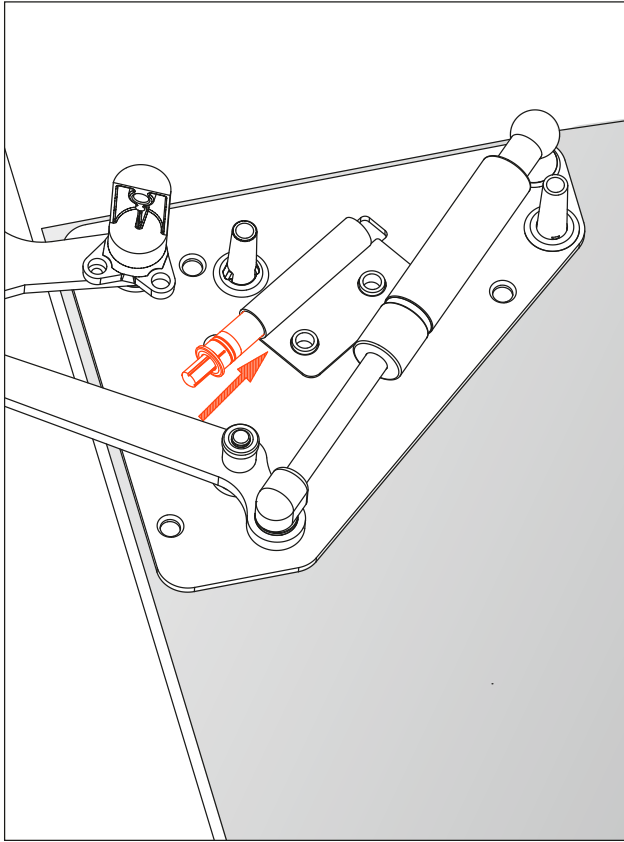

Installing the cover

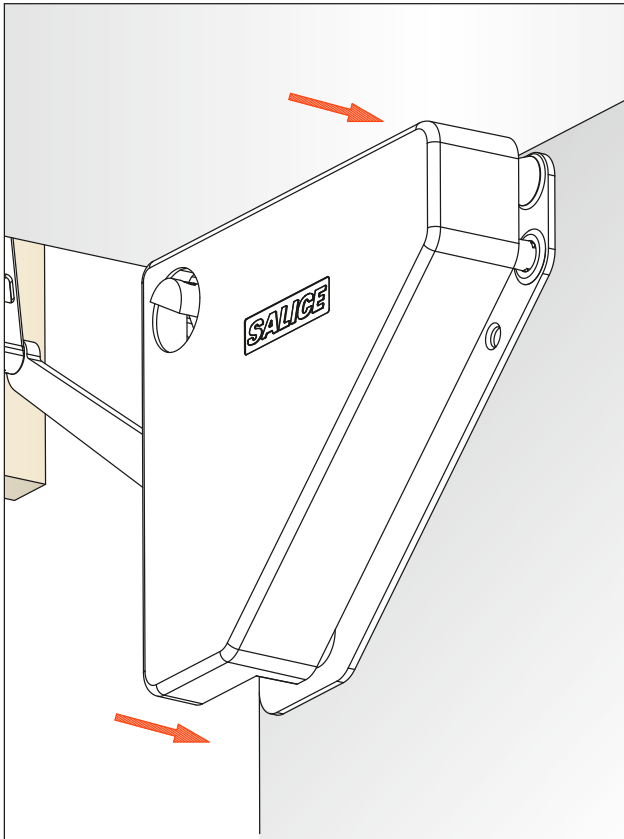

Fitting the stabilizer bar

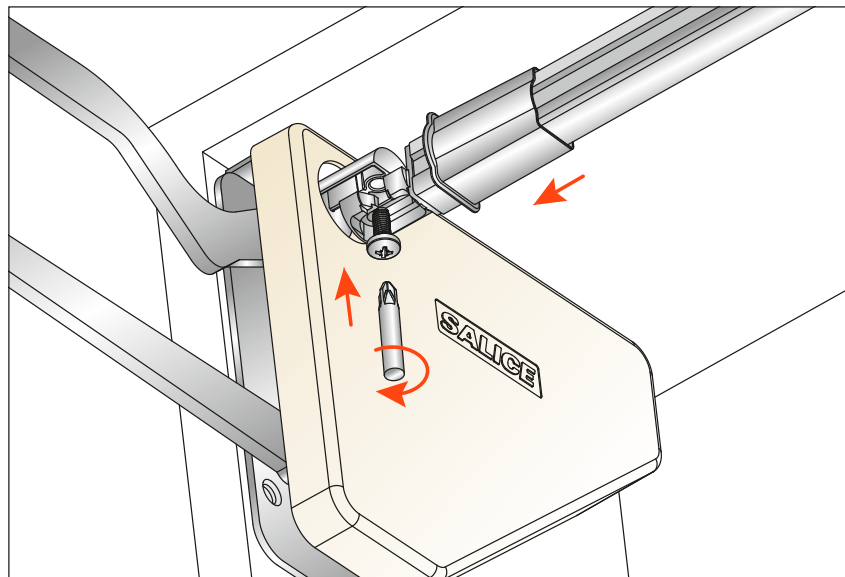

Insert the ends of the bar into the housing and fasten the fixing screw.

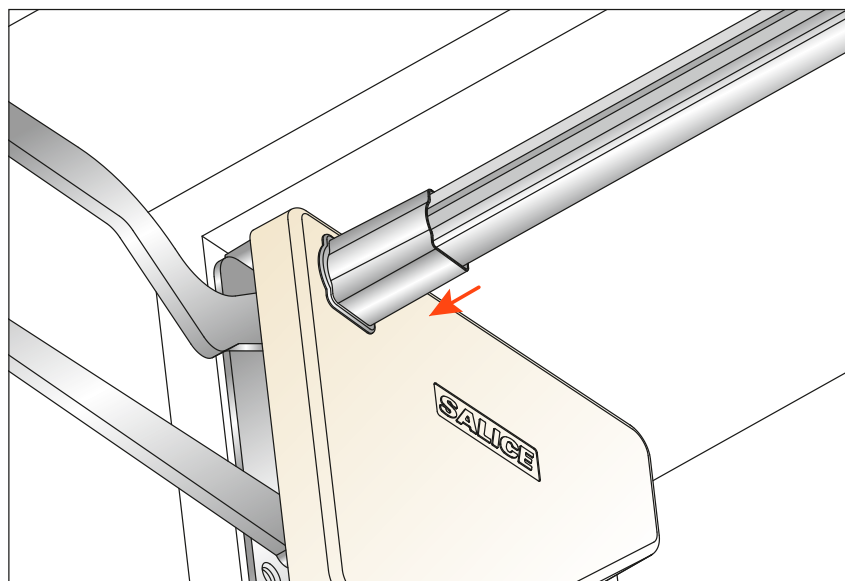

Slide the sleeves over the housing at each end of the bar.

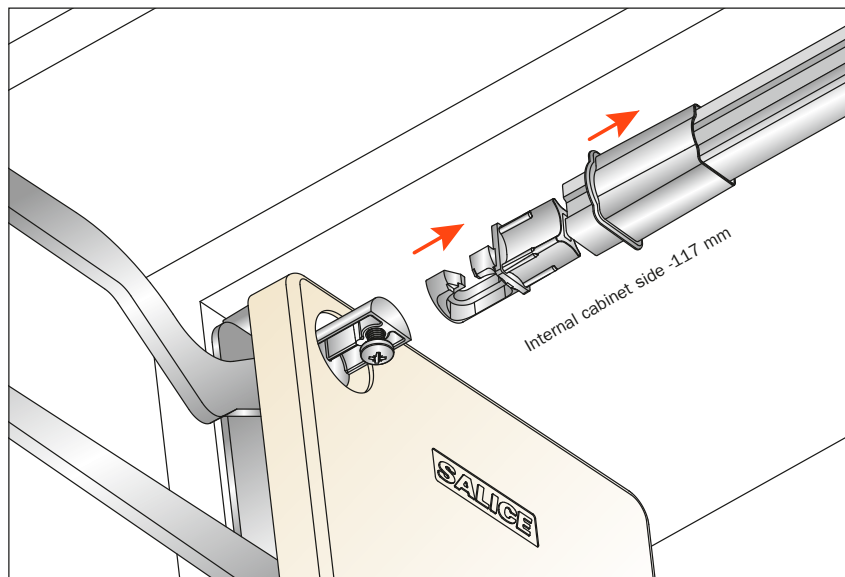

In case of cabinets with special widths, pull the bar end off one side and cut it accordingly. Re-insert the bar end into the housing.

Fitting the door to the cabinet

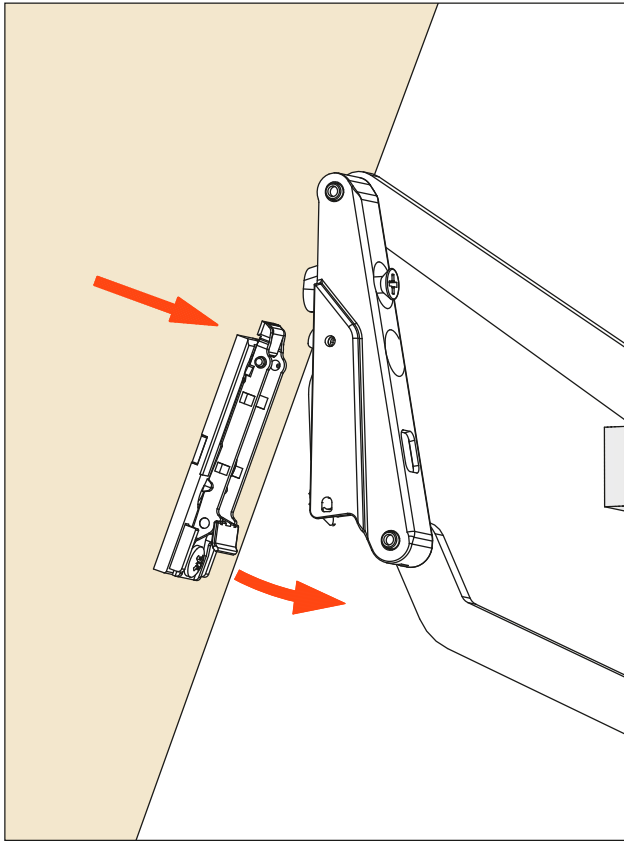

Adjustments and additional fixing

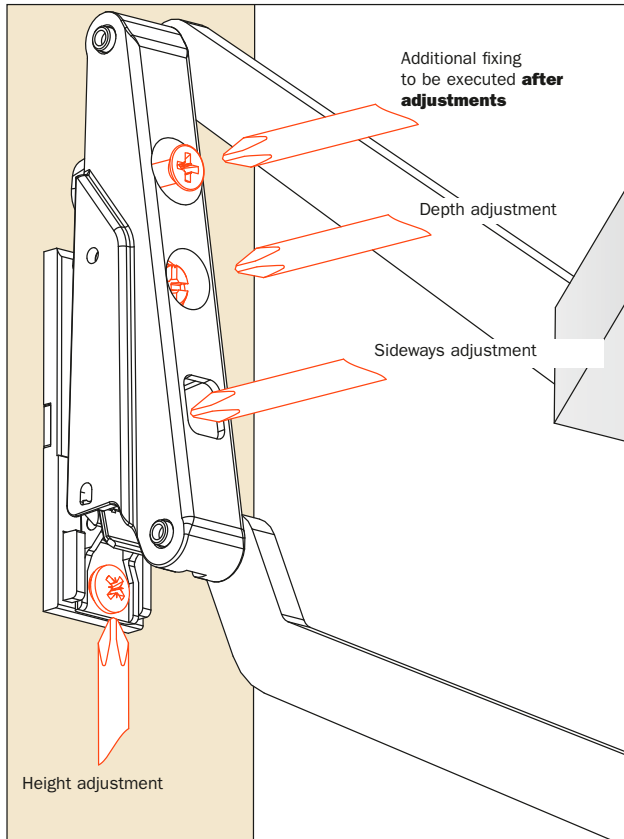

Dimensions of the system for doors from 360 to 440 mm height

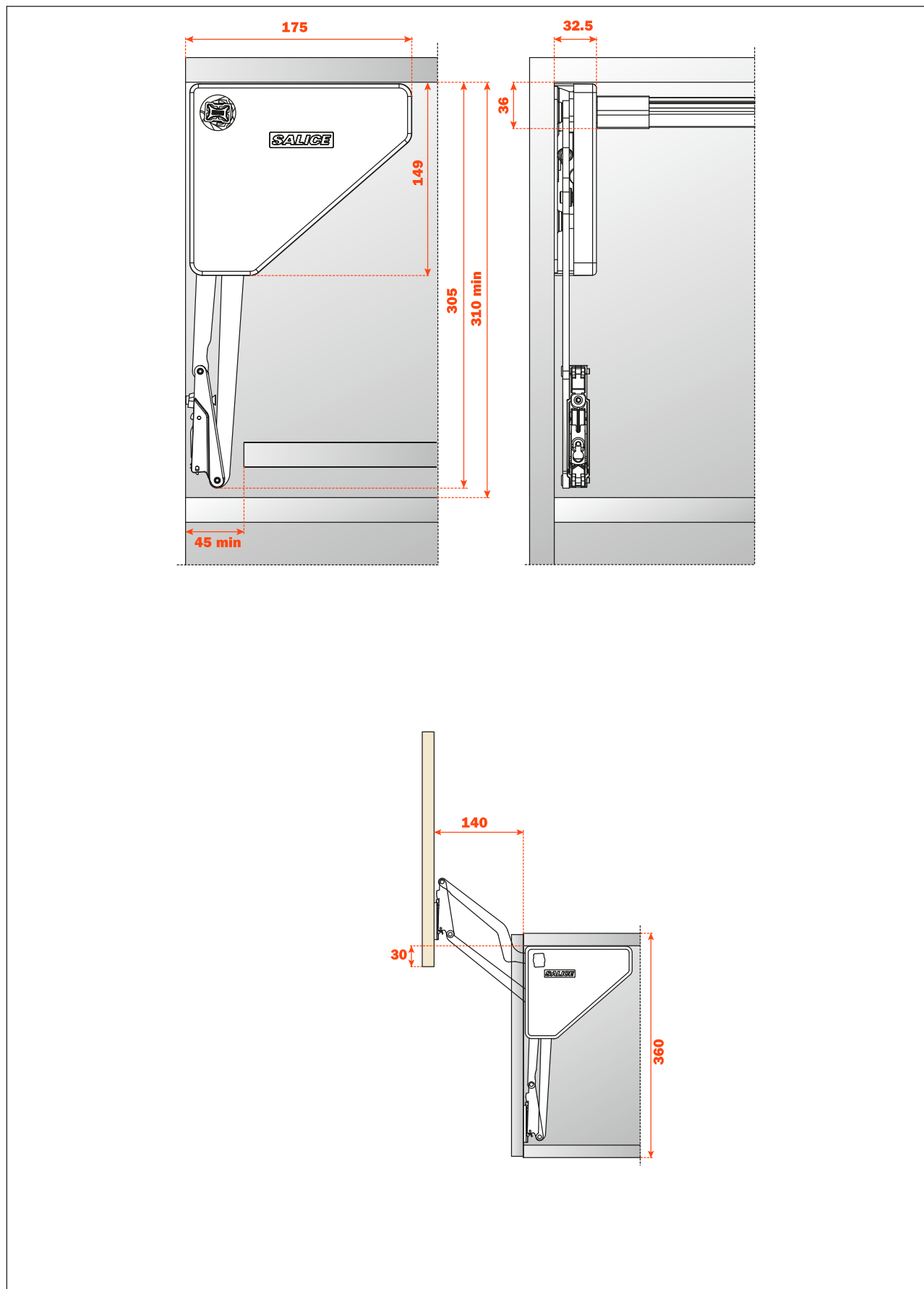

Dimensions of the system for doors from 440 to 660 mm height

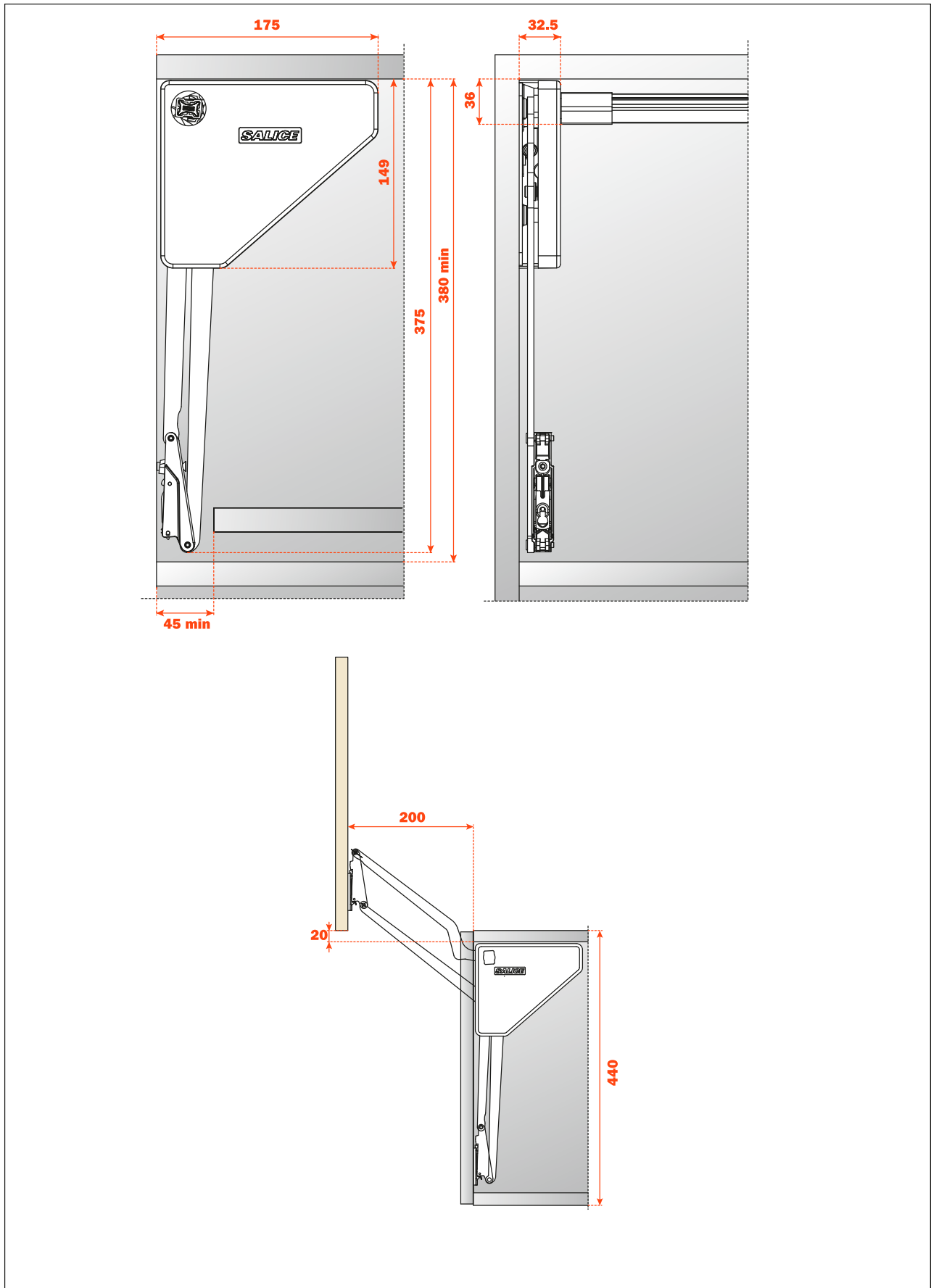

Disassembly

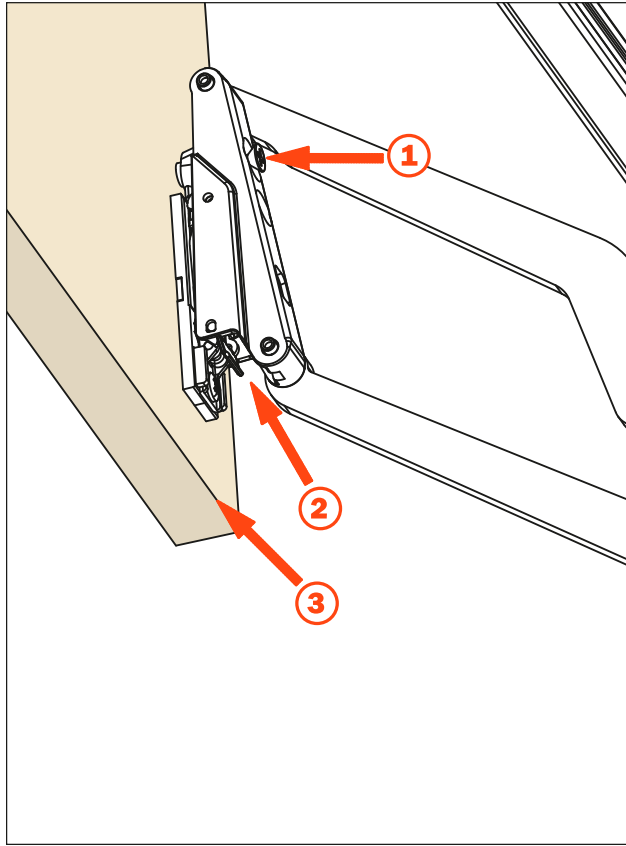

- 1)** Loosen the additional wood screw
- 2)** then press firmly on the mounting plate lever
- 3)** push the door



Chart for FLMGSExxx pistons with single-operation door opening for doors from 360 to 440 mm height

Chart to define the exact strength of the pistons to be used in relationship with the dimensions and weight of the doors.



Chart for FLMGRExxx pistons with progressive-operation door opening for doors from 360 to 440 mm height

Chart to define the exact strength of the pistons to be used in relationship with the dimensions and weight of the doors.

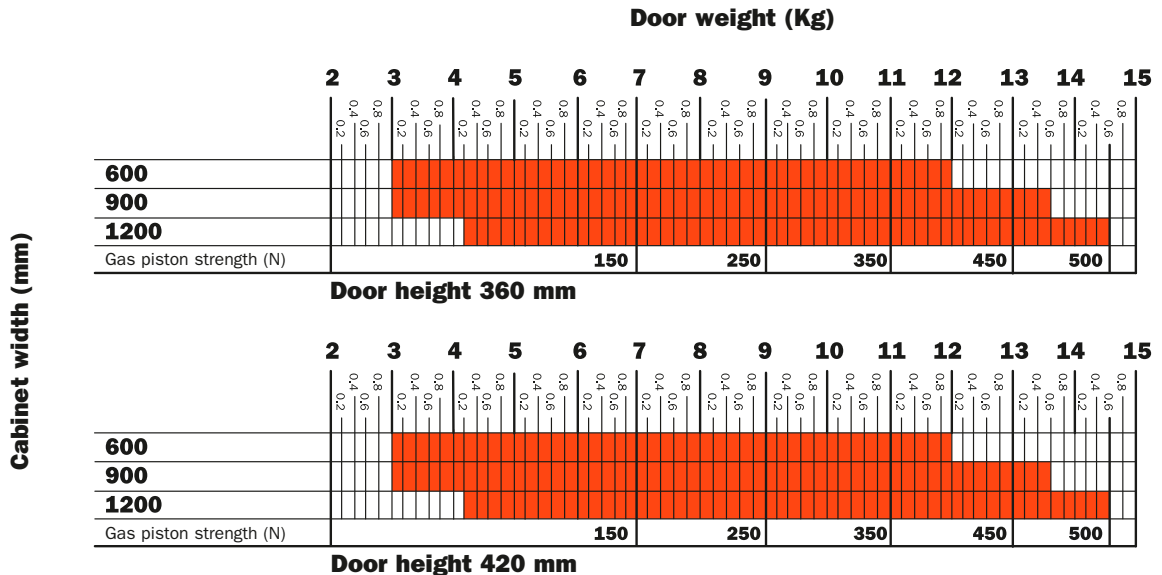

Lift - Opening systems - Parallel opening door - Gas piston strength

Chart for FLMGSExxx pistons with single-operation door opening for doors from 440 to 660 mm height.

Chart to define the exact strength of the pistons to be used in relationship with the dimensions and weight of the doors.

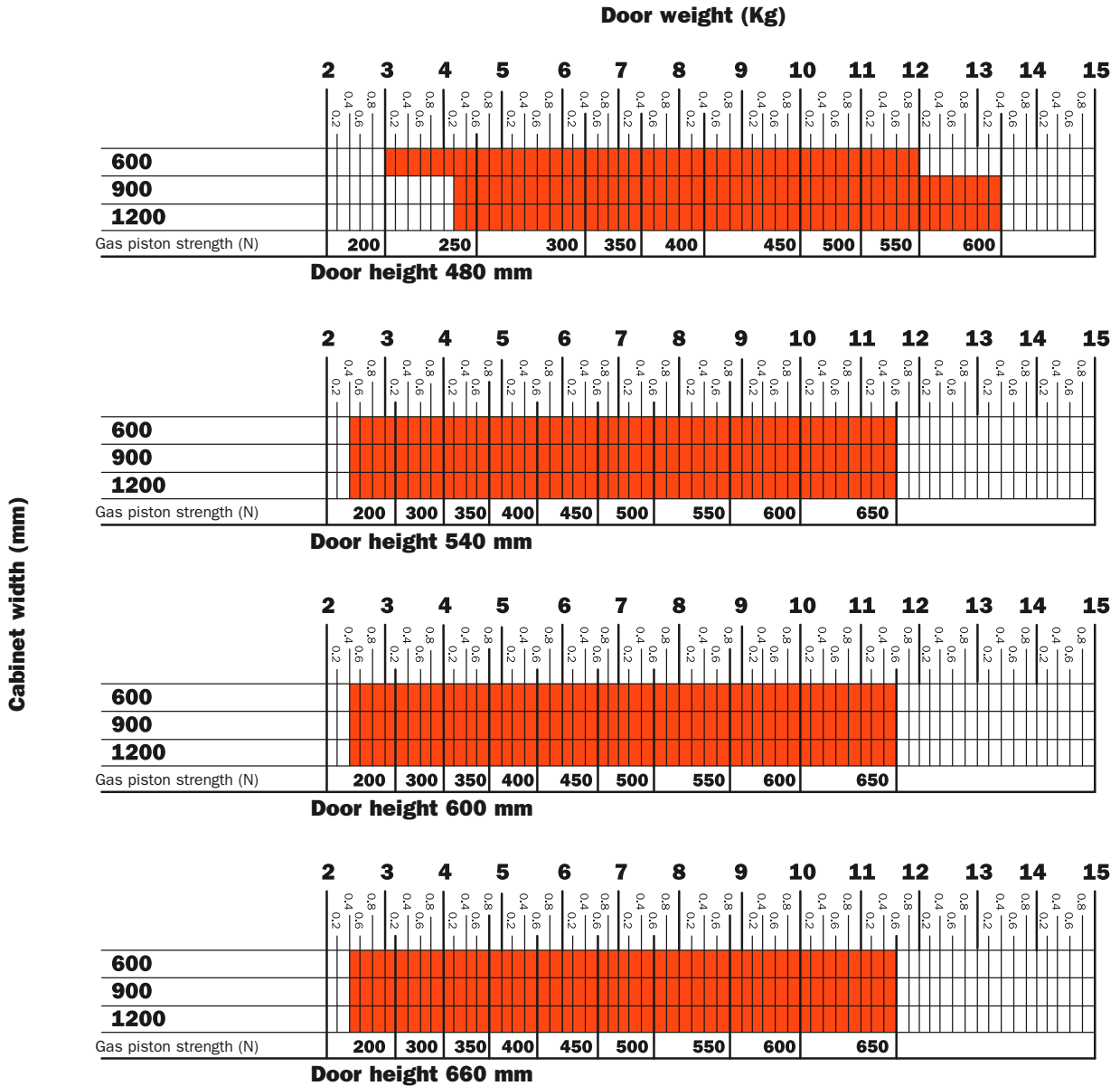
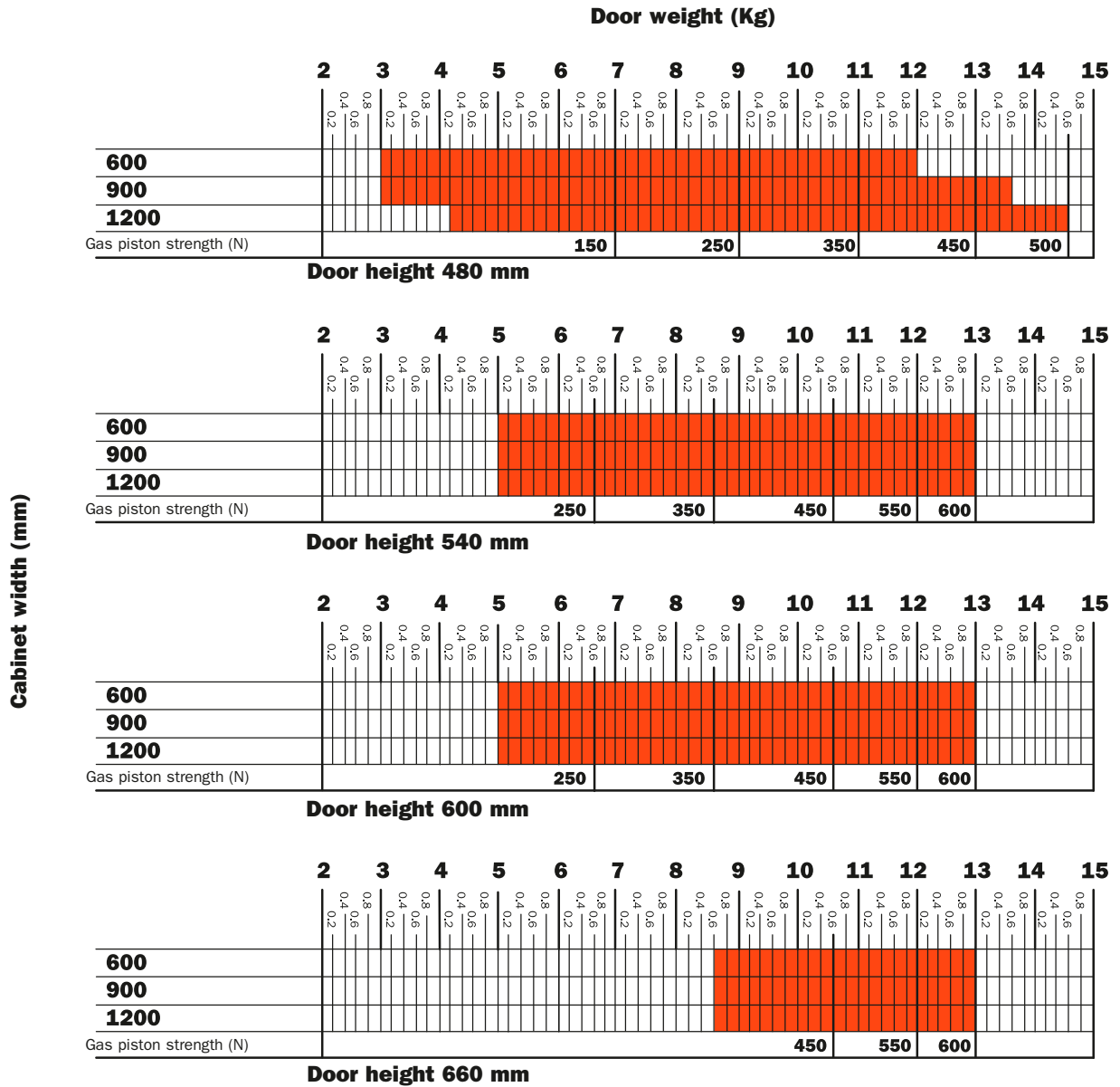

Chart for FLMGRExxx pistons with progressive-operation door opening for doors from 440 to 660 mm height.

Chart to define the exact strength of the pistons to be used in relationship with the dimensions and weight of the doors.



Lift - Opening systems - Swing opening door





Part number composition

- F** = Lifting system
- B** = Swing opening door
- XXXXXX** = Special options
- SN** = Cover with Salice logo / **99** = Cover with arrangement for screw cover cap
- X** = Colour of the cover
- X1** = Cover with silk-screen printed logo

FBXXXXXS^NX

G = grey cover
1 = white cover
9 = nickel-pl. cover



FBXXXXX999

Part number for Lift system supplied with nickel-plated cover with arrangement for screw cover cap.

Screw cover cap to be ordered separately.



FBXXXXX_9X1

Part number for Lift system supplied with nickel-plated cover with silk-screen printed logo.



Components of the system for wooden door

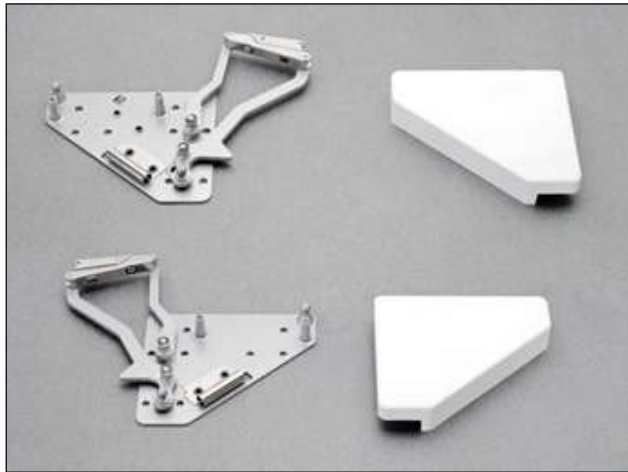

FBXXXXXXSNX

Lifting system - **right** side

Lifting system - **left** side

Cover

Colour of the cover:

G = grey
1 = white
9 = nickel-pl.

Packing

Boxes 6 pairs

To be ordered separately:

BAPGR39

Mounting plate for door



Packing

Boxes 300 pcs.

DO0SSNG

Smove

For doors of small weight and dimensions.



Packing

Boxes 250 pcs.

FLMGSE **XXX** ← Fill with the required piston strength

Gas piston.
See page 343 to complete the part number with the appropriate piston strength.



Packing

Boxes 12 pcs.

DO0FSNG

Smove

For doors of middle weight and dimensions.



Packing

Boxes 250 pcs.

FLMGRE **XXX** ← Fill with the required piston strength

Progressive gas piston.
See page 344 to complete the part number with the appropriate piston strength.



Packing

Boxes 12 pcs.

DO0LSNG

Smove

For doors of large weight and dimensions.



Packing

Boxes 250 pcs.



Components of the system for alu-framed door

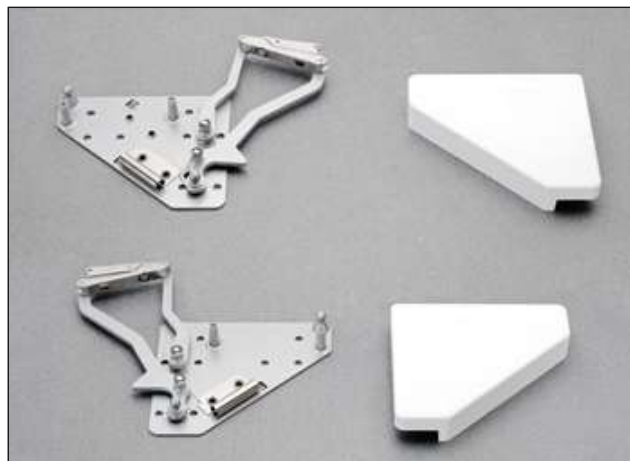

FBXXXXXXSNX

Lifting system - **right** side

Lifting system - **left** side

Cover

Colour of the cover:

G = grey
1 = white
9 = nickel-pl.

Packing

Boxes 6 pairs

To be ordered separately:

BAP3R39



Mounting plate for door

Packing

Boxes 300 pcs.

D00SSNG



Smove

For doors of small weight and dimensions.

Packing

Boxes 250 pcs.

FLMGSE XXX ← Fill with the required piston strength



Gas piston.
See page 343 to complete the part number with the appropriate piston strength.

Packing

Boxes 12 pcs.

D00FSNG



Smove

For doors of middle weight and dimensions.

Packing

Boxes 250 pcs.

FLMGRE XXX ← Fill with the required piston strength



Progressive gas piston.
See page 344 to complete the part number with the appropriate piston strength.

Packing

Boxes 12 pcs.

D00LSNG



Smove

For doors of large weight and dimensions.

Packing

Boxes 250 pcs.

DBZXBH9



Support for plate with fixing screws.

Packing

Boxes 150 pcs.

Drilling pattern for wooden door and alu-framed door

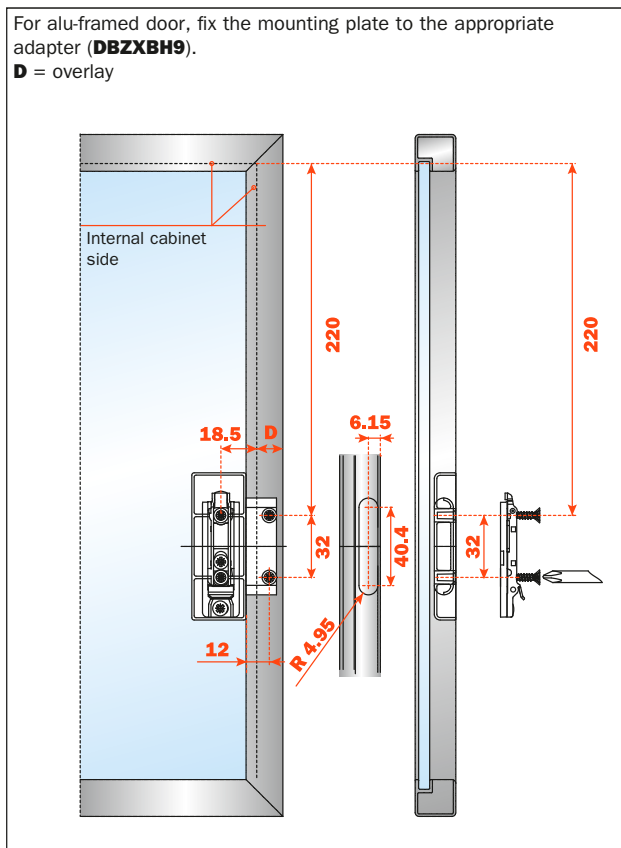
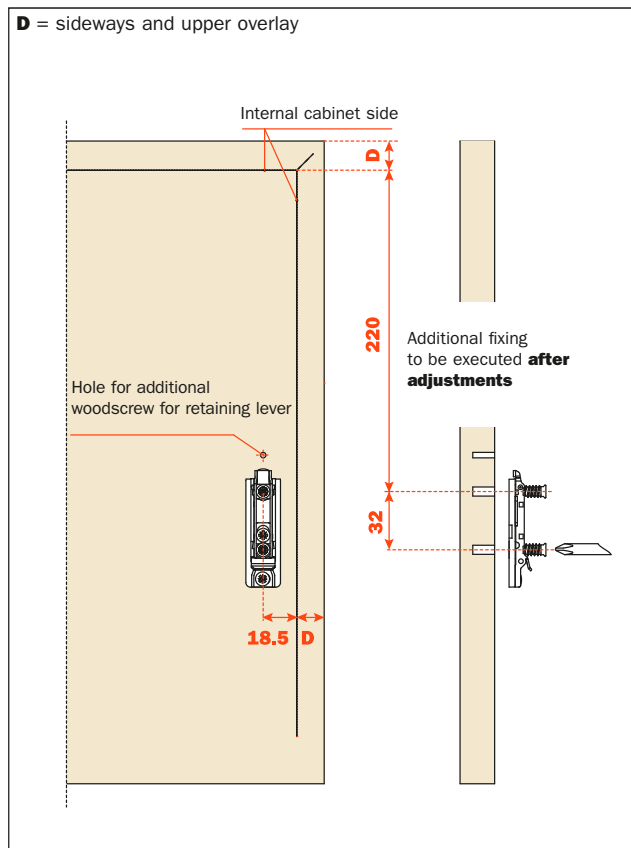

Fixing the support to the cabinet side

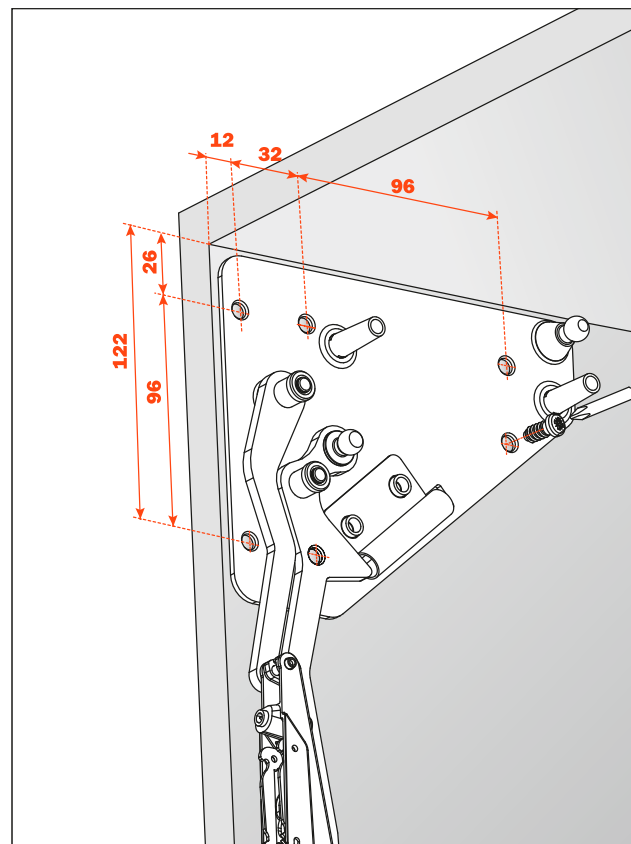

Deploying the piston

Carefully press each end of the piston securely onto the pins on the bracket and lifting arm, ensuring that the body of the piston is uppermost.

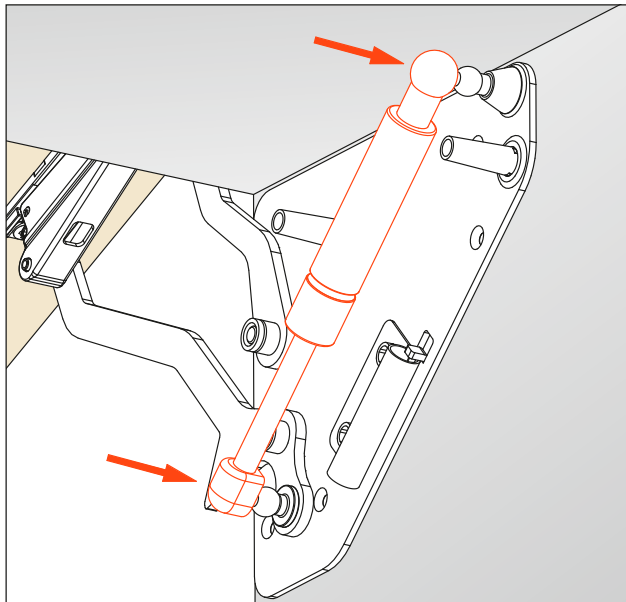

Installing the Smove

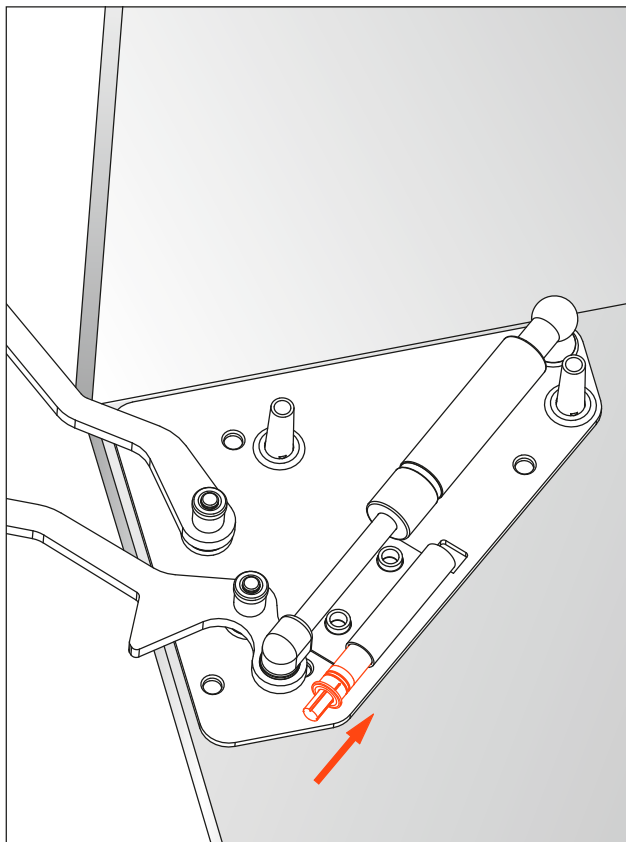

Fitting the door to the cabinet

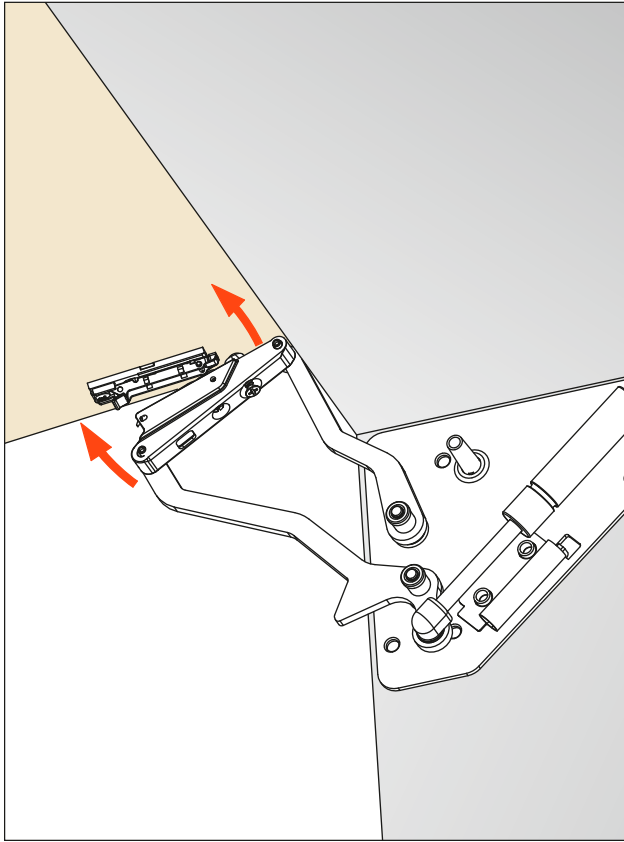

Installing the cover

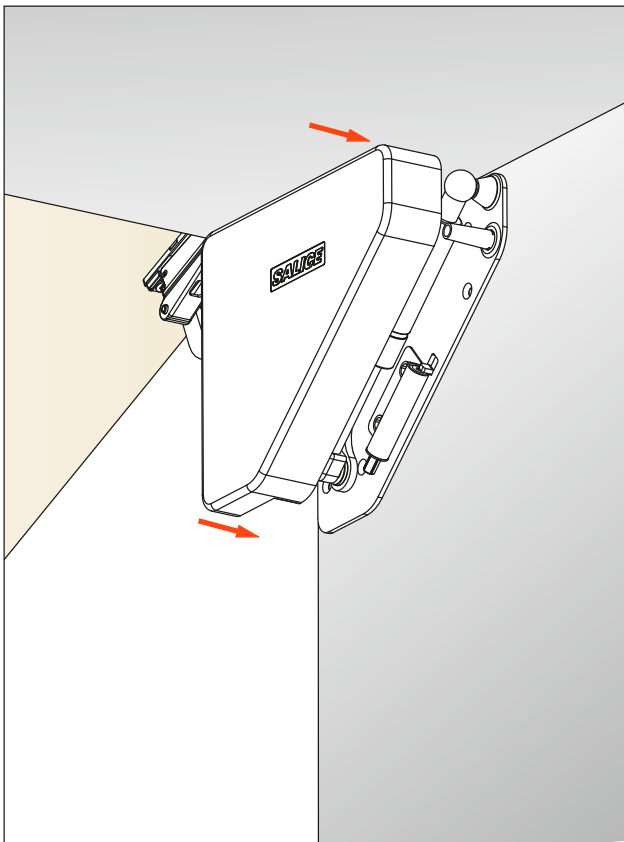

Adjustments and additional fixing

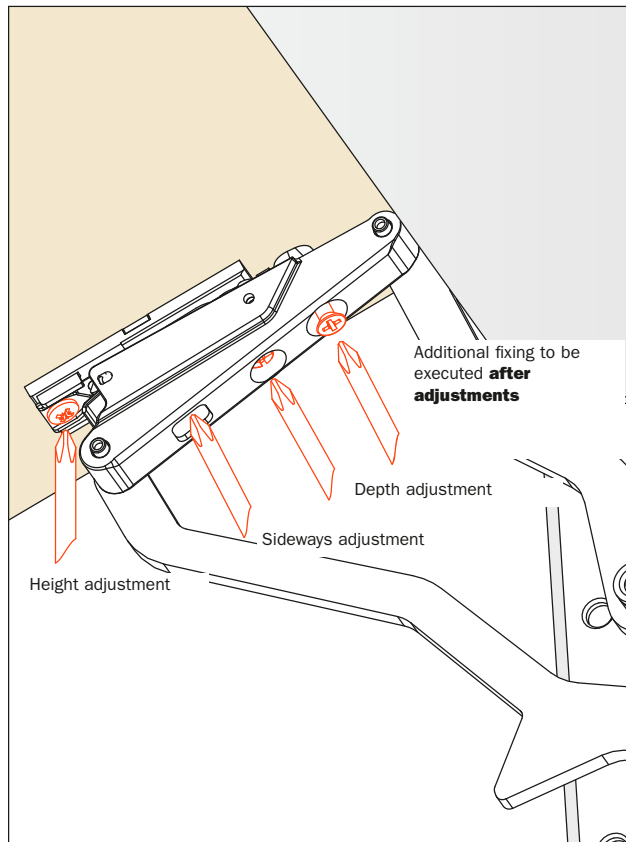

Disassembly

- 1) Loosen the additional wood screw
- 2) then press firmly on the mounting plate lever
- 3) push the door

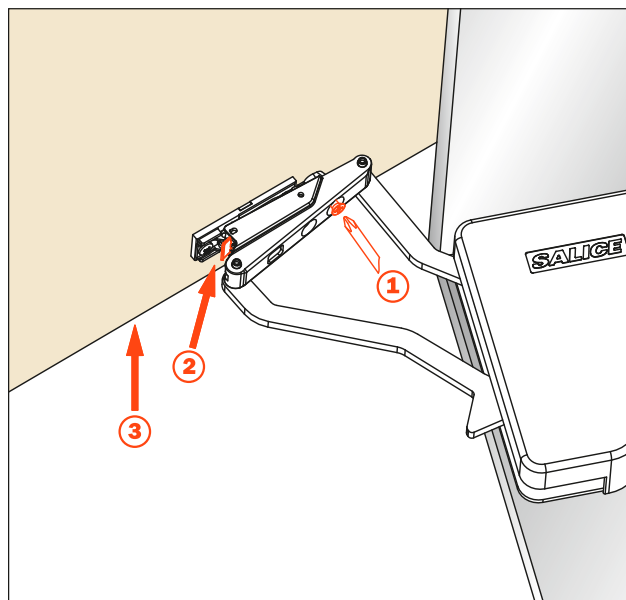

Dimensions of the system

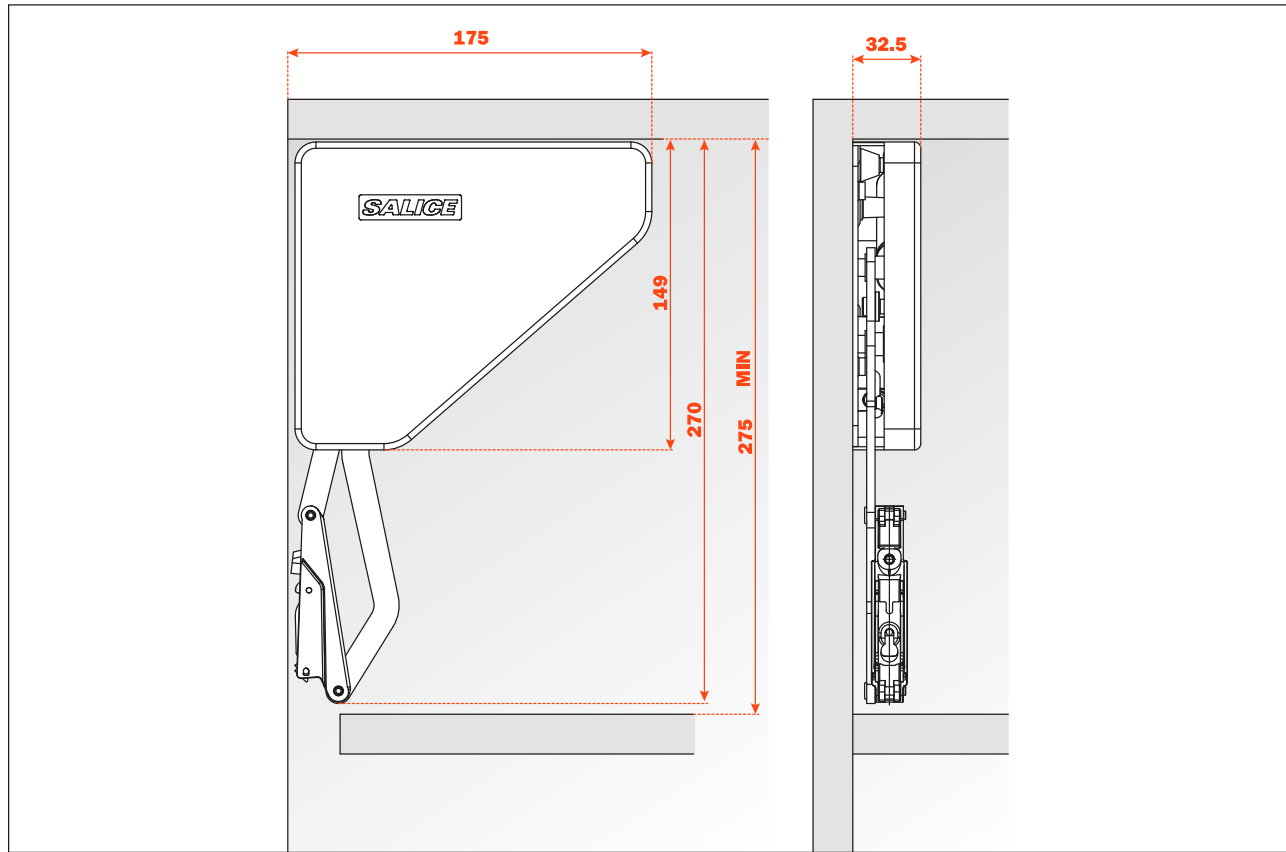

Assembly scheme for cabinets over 1200 mm width

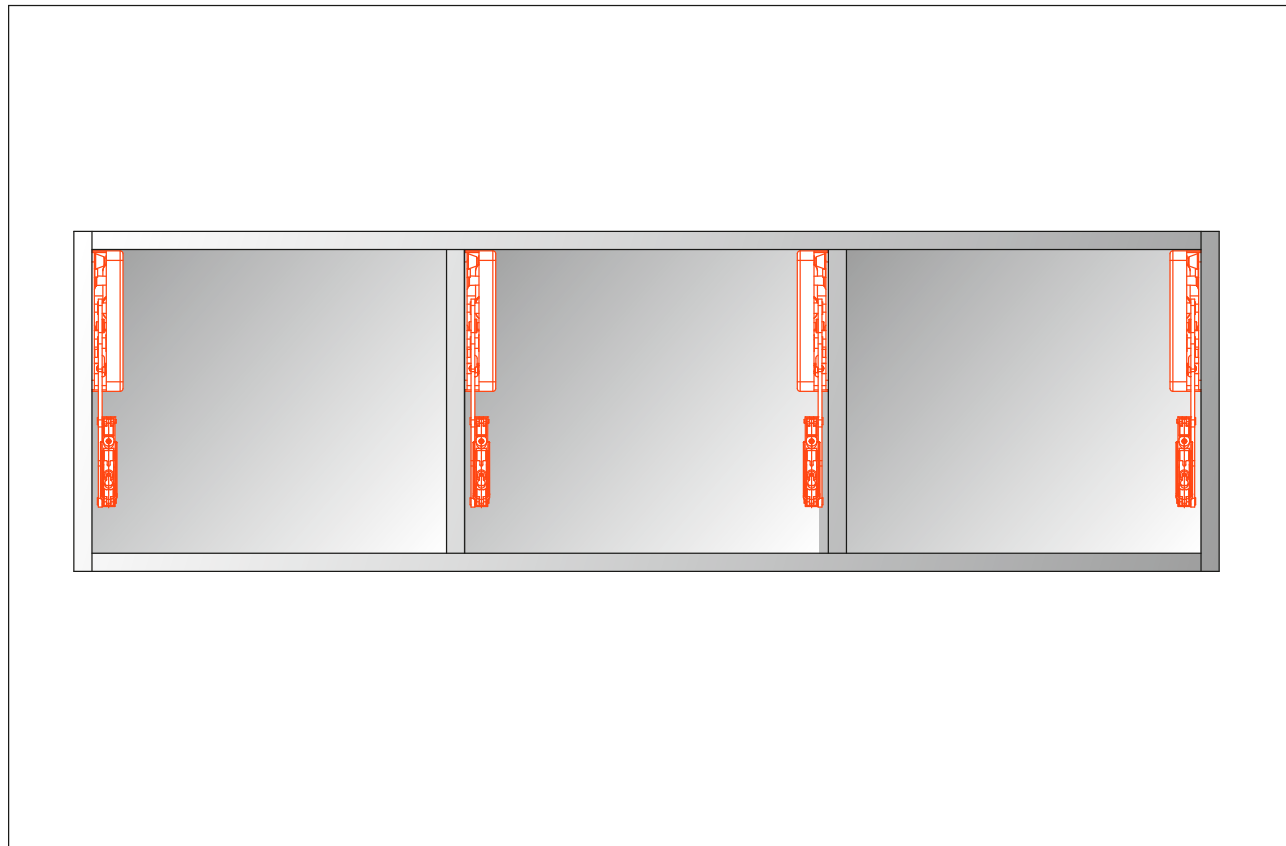

Dimensions of the open door

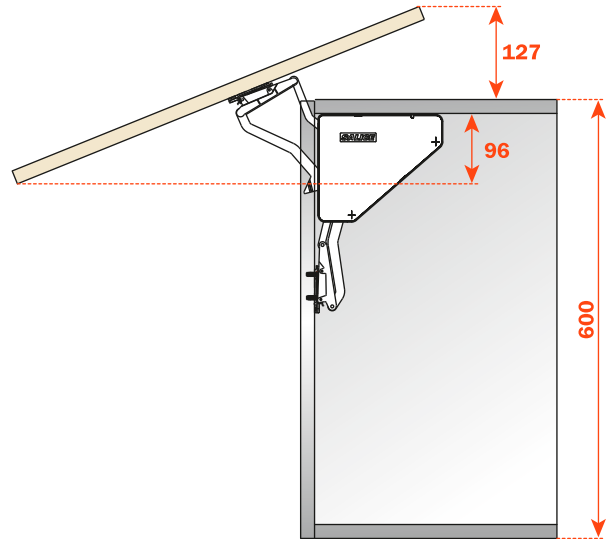
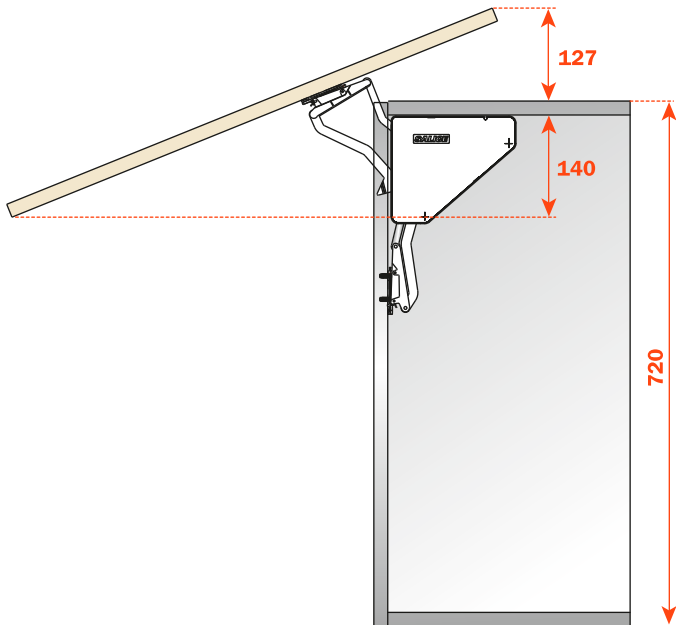
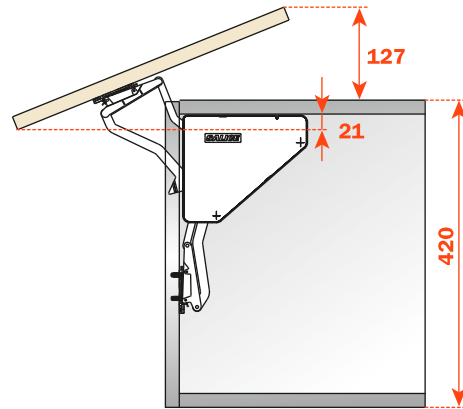
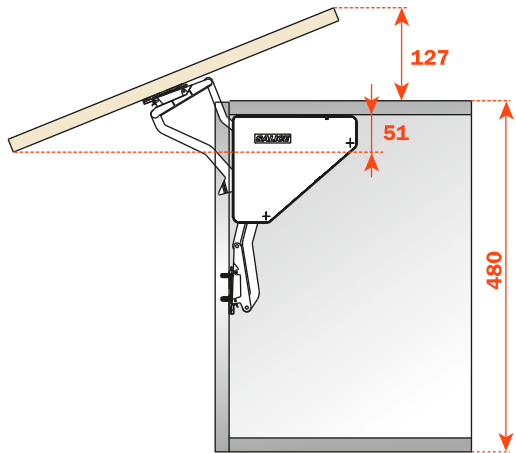

Chart for FLMGSExxx pistons with single-operation door opening

Chart to define the exact strength of the pistons to be used in relationship with the dimensions and weight of the doors.

Cabinet width (mm)

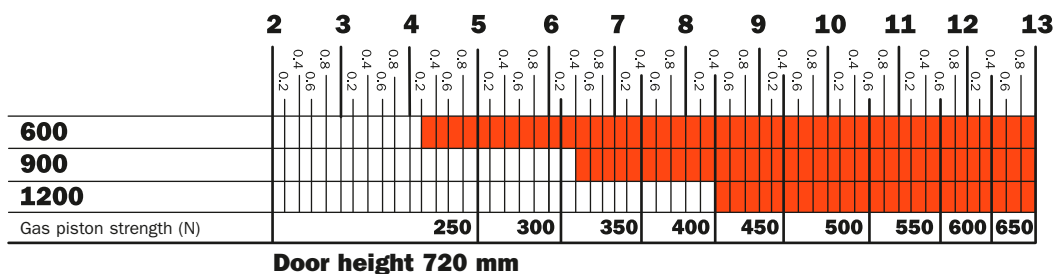
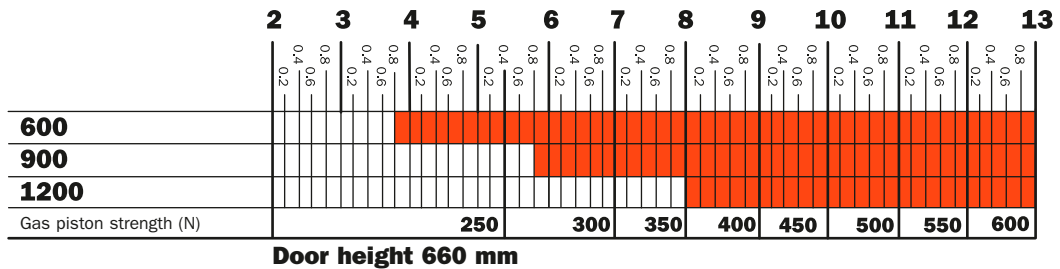
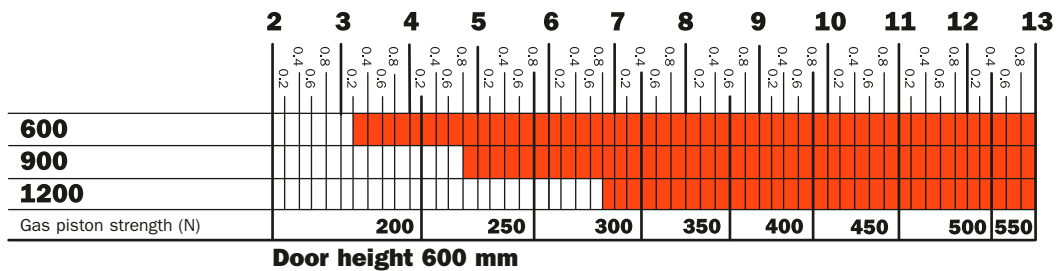
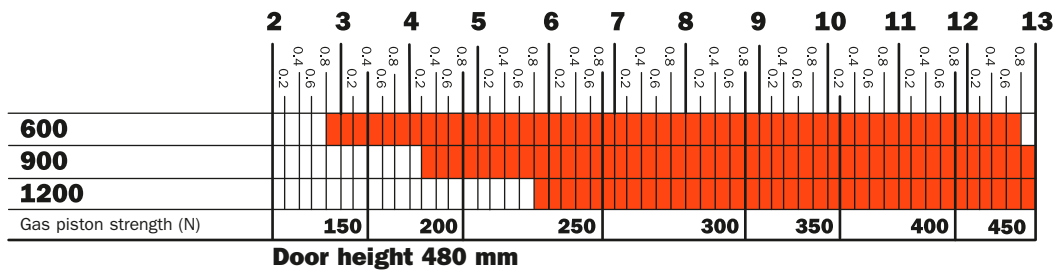
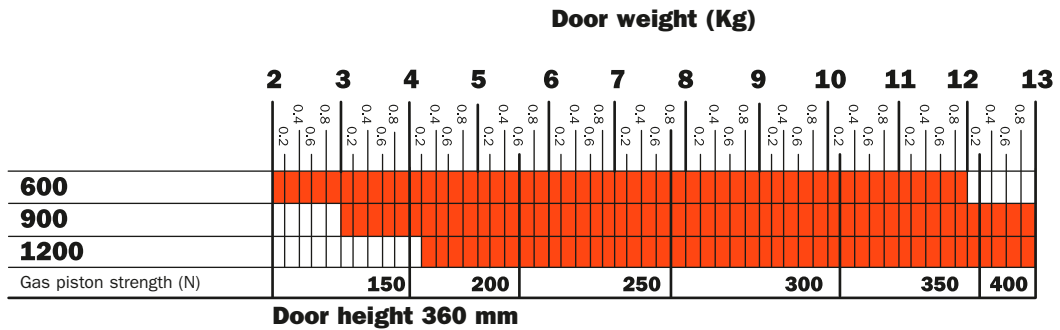
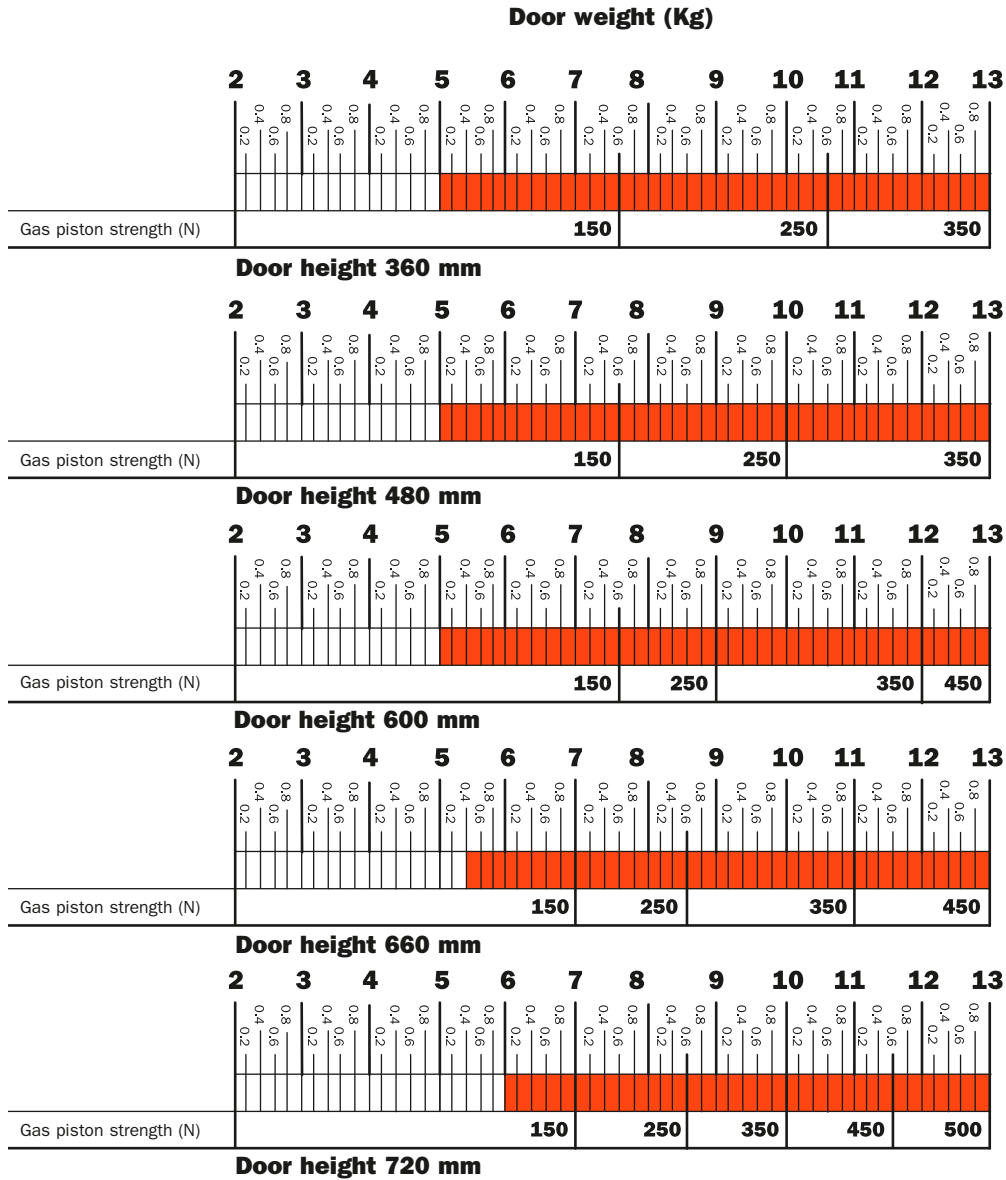

Chart for FLMGRExxx pistons with progressive-operation door opening

Chart to define the exact strength of the pistons to be used in relationship with the dimensions and weight of the doors.

Cabinet width 600, 900 and 1200 mm



Connecting fitting

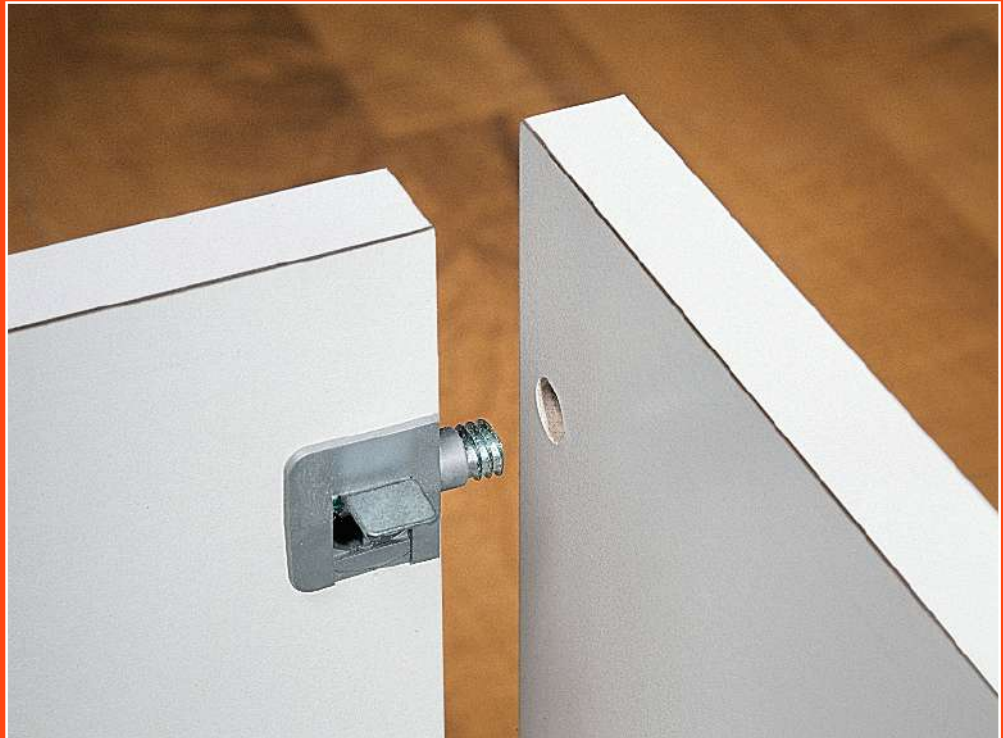

Connecting fitting

Simple nylon connecting fitting, knock-in.

- G98XA15** white
- G98XAG5** grey
- G98XA3V** black
- G98XAUV** brown colour.

Packing

Boxes 1.200 pcs.
Pallets 28.800 pcs.



Drilling pattern

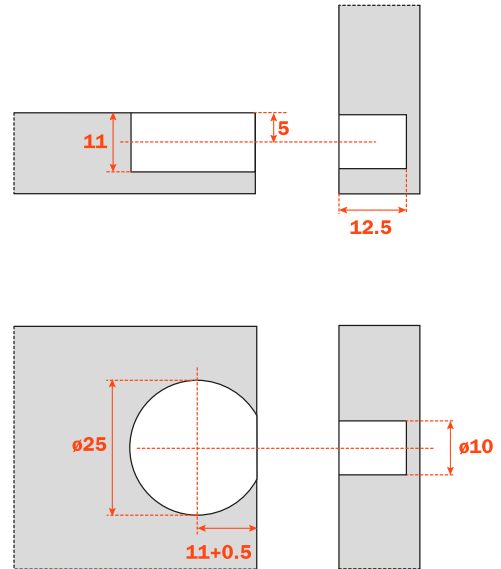

All versions of the connecting fittings are available in the following standard colours

D98XAX3PE

Insertion tool for connecting fittings **G98X** and **G98Y**.



Assembly

1
Insert the connecting fitting in one of the two panels to be connected. Introduce the threaded part of the connecting fitting into the hole on the second panel, taking care that the lever is in the raised, open position.

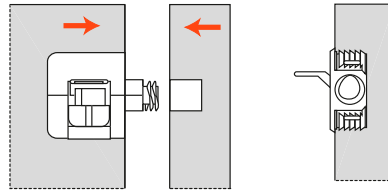

2
Bring the two panels together and turn the lever all the way down.

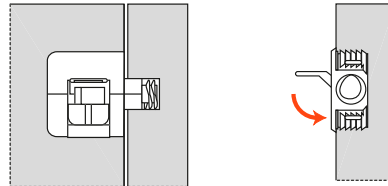

3
While rotating, the threaded part pulls the two panels together, joining them in a secure way. The metal thread is driven firmly into the inner walls of the 10 mm hole.

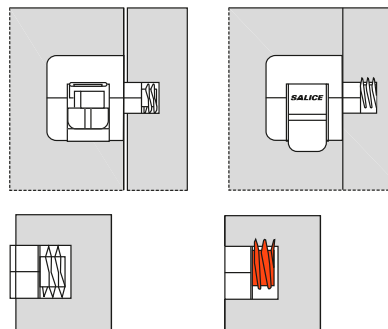

Disassembly.

1
Return the lever to the open position. Separate the two elements. Nothing remains inserted in the 10 mm hole.

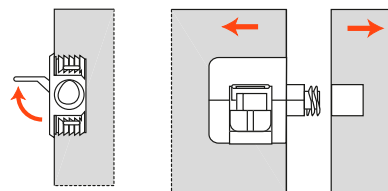

Accessories



Screw cover caps.

S2BX83H9



Symmetrical steel screw cover cap, it can be personalised on request.

For all Series Silentia, 100, 200, 700, Logica, F, B, and 400 hinges.

S2MX83H9



Symmetrical steel screw cover cap with embossed logo.

For all Series Silentia 100, 200, 700, Logica, F, B, and 400 hinges.

S8XX83H9



Symmetrical steel screw cover cap, it can be personalised on request.

For Series Silentia 800 and 800 hinges.

S8CX83H9



Symmetrical steel screw cover cap with embossed logo.

For Series Silentia 800 and 800 hinges.

S2XX83A1



Symmetrical plastic screw cover cap, it can be personalised on request.

For all Series 100, 200, Logica, F and 400 hinges.

S6XX83C1



S6XX83C1
Plastic screw cover cap with symmetrical printed logo.
For all Series 600 hinges.

S6SX83C1 - S6DX83C1
Plastic screw cover cap with asymmetrical printed logo.
For all Series 600 hinges.

S9XX83H9



Steel symmetrical screw cover cap, it can be personalised on request.

For Series 900, Silentia Series 900, F hinges and complementary hinges Series 200 and 700.

S9CX83H9



Symmetrical steel screw cover cap with embossed logo.

For Series 900, Silentia Series 900, F hinges and complementary hinges Series 200 and 700.

S9XX83C1



Symmetrical plastic screw cover cap, it can be personalised on request.

For Series 900, Silentia Series 900, F hinges and complementary hinges Series 200 and 700.

Flange cover caps

S2XX85H9



Steel flange cover cap, it can be personalised on request.

For all Series Silentia, 100, 200, 300, 700, 800 and 900.

S2CX85H9



Steel flange cover cap with embossed logo.

For all Series Silentia, 100, 200, 300, 700, 800 and 900.

Spacers, gauge and fancy cover for Silentia hinges

Silentia

S2XF86



Spacer to reduce the drilling depth for 155° hinges.

S2XF86BT = 0.6 mm

S2XF86AT = 1.2 mm

S2XF86KT = 1.8 mm

S2XX86



Spacer to reduce the drilling depth for 94°, 105° and 110° hinges.

S2XX86BT = 0.6 mm

S2XX86AT = 1.2 mm

S2XX86KT = 1.8 mm

D_A_AC_SN



Gauge to check the diameter and the depth of the drilling.

D1A6AC3SN = 12 mm

D2ABACGSN = 15.5 mm

D7A6ACYSN = 13.5 mm

D1Z6HSK



Fancy cover for metal profiles hinges.

Fancy covers for glass door hinge cup

P2CTAX3



P2CBAX3



P2CQAX3



Plastic, black

P2CTA13



P2CBA13



P2CQA13



Plastic, lacquered black

P2CTAX1



P2CBAX1



P2CQAX1



Plastic, white

P2CTA08



P2CBA08



P2CQA08



Plastic, bright gold effect

P2CTA0W



P2CBA0W



P2CQA0W



Plastic, gold effect

P2CTA06



P2CBA06



P2CQA06



Plastic, bright chrome

P2CTA09



P2CBA09



P2CQA09



Plastic, silver effect

Spacers for Series 200, F and 600 hinges

S6A786XG



Spacer for hinges with 26 mm diameter.

To be used to reduce the cup drilling depth by 1.5 mm.

S2A786XG



Spacer for hinges with 35 mm diameter.

To be used to reduce the cup drilling depth by 1.4 mm.

SFA586XG



Spacer for hinges with 40 mm diameter.

To be used to reduce the cup drilling depth by 1.5 mm.

Stop devices

S2A637XF



Stop device at 86° for all hinges with 94° opening and 35 mm cup diameter.



SBA237XG



Stop device at 90° for all Series B hinges.



S2BF37XY



Stop device at 110° for all hinges:

C2_M (pages 51, 77 and 91)
C2_D (pages 33 and 93)
C2_F (page 97)
C2_U (page 211)
C2_T (page 213)



S2AF37X3



Stop device at 120° for all hinges:

C2_M (pages 51, 77 and 91)
C2_D (pages 33 and 93)
C2_F (page 97)
C2_U (page 211)
C2_T (page 213)



S2BH37XG

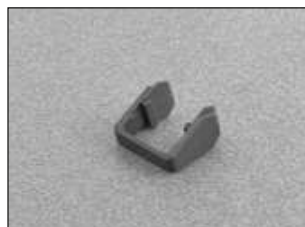

Stop device at 110° for hinge:

C2_H (page 95)



S2BM37XG



Stop device at 90° for all hinges:

C2_M (pages 51, 77 and 91)



Lined area for taking notes, consisting of multiple horizontal lines.

ARTURO SALICE S.p.A.

VIA PROVINCIALE NOVEDRATESE, 10
22060 NOVEDRATE (COMO) ITALIA
TEL. 031 790424
FAX 031 791508
info.salice@salice.com
www.salice.com

DEUTSCHE SALICE GMBH

RUDOLF DIESEL STR. 10
POSTFACH 1154
74382 NECKARWESTHEIM
TEL. 07133 9807-0
FAX. 07133 9807-16
info.salice@deutschesalice.de
www.deutschesalice.de

SALICE UK LTD.

KINGFISHER WAY
HINCHINGBROOKE BUSINESS PARK
HUNTINGDON CAMBS PE 29 6FN
TEL. 01480 413831
FAX. 01480 451489
info.salice@saliceuk.co.uk
www.saliceuk.co.uk

DEUTSCHE SALICE GMBH

VERKAUFSBÜRO NORD
RINGSTRASSE 36/A30 CENTER
32584 LÖHNE
TEL. 05731 15608-0
FAX. 05731 15608-10
vknord@deutschesalice.de
www.deutschesalice.de

SALICE AMERICA INC.

2123 CROWN CENTRE DRIVE
CHARLOTTE NC. 28227
TEL. 704 8417810
FAX. 704 8417808
info.salice@saliceamerica.com
www.saliceamerica.com

SALICE FRANCE S.A.R.L.

ROUTE DE GOA ZAC LES 3 MOULINS
06600 ANTIBES
TEL. 0493 330069
FAX. 0493 330141
info.salice@salicefrance.com
www.salicefrance.com

SALICE CANADA INC.

4025 SLADEVIEW CRESCENT
UNIT # 7-9
MISSISSAUGA, ONTARIO L5L 5Y1
TEL. 905 8208787
FAX. 905 8207226
info.salice@salicecanada.com
www.salicecanada.com

SALICE ESPAÑA, S.L.U.

CALLE COPÉRNICO, 11
POLÍGONO INDUSTRIAL
COLL DE LA MANYA
08403 GRANOLLERS (BARCELONA)
TEL. 938 46 88 61
FAX 938 49 11 97
info.salice@saliceespana.es
www.saliceespana.es

We reserve the right to change technical specifications without notice.

